

Service
Service
Service



Service Manual



TABLE OF CONTENTS

	Page
Location of pc boards & Version variations	1-2
Technical Specifications	1-3
Measurement setup	1-4
Service Aids, Safety Instruction, etc.	1-5
Preparations & Controls	1-7 to 1-10
Disassembly Instructions & Service positions	2
Service Test Programs & DEMO Mode	3
Set Block diagram	4
Set Wiring diagram	5
Front Board	6
Tuner Board: Systems Non-Cenelec	7A
Systems Cenelec	7B
ETF7 Tape Module	9
3CDC-LC-MP3CD2002 Module	10
MMPWR 100W Module	11
AF9 Board	12
Set Mechanical Exploded view & parts list	13



© Copyright 2002 Philips Consumer Electronics B.V. Eindhoven, The Netherlands
All rights reserved. No part of this publication may be reproduced, stored in a retrieval system or transmitted, in any form or by any means, electronic, mechanical, photocopying, or otherwise without the prior permission of Philips.

Published by SL 0352 Service Audio Printed in The Netherlands Subject to modification



3140 785 32820

Version 1.0



PHILIPS

SPECIFICATIONS**GENERAL:**

Mains voltage : 110-127V/220-240V Switchable for /21
230V for /22/25/30
Mains frequency : 50/60Hz
Power consumption : < 1W at ECO Standby (FTD off)
< 25W Standby (Demo off)
< 175W 1/8 Prated
Clock accuracy : < 4 seconds per day
Dimension centre unit : 265 x 310 x 381mm

TUNER:**FM**

Tuning range : 87.5-108MHz
Grid : 50kHz
IF frequency : 10.7MHz \pm 20kHz
Aerial input : 75 Ω coaxial
Sensitivity at 26dB S/N : < 7 μ V
Selectivity at 600kHz bandwidth : > 25dB
IF rejection : > 60dB [> 75dB]
Image rejection : > 25dB
Distortion at RF=1mV, dev. 75kHz : < 3%
-3dB Limiting point : < 8 μ V
Crosstalk at RF=1mV, dev. 40kHz : > 18dB

MW

Tuning range : 531-1602kHz
530-1700kHz for /21
Grid : 9kHz
10kHz for /21
IF frequency : 450kHz \pm 1kHz
Aerial input : Frame aerial
Sensitivity at 26dB S/N : < 4.0mV/M
Selectivity at 18kHz bandwidth : > 18dB
IF rejection : > 45dB
Image rejection : > 28dB
Distortion at RF=50mV, m=80% : < 5%

LW

Tuning range : 153-279kHz for /22
Grid : 3kHz
IF frequency : 450kHz \pm 1kHz
Aerial input : Frame aerial
Sensitivity at 26dB S/N : < 7.0mV/M
Selectivity at 18kHz bandwidth : > 24dB
IF rejection : > 30dB
Image rejection : > 30dB
Distortion at RF=50mV, m=80% : < 5%

AMPLIFIER:

Output power (6 Ω , 1 kHz, 10% THD) : 2 x 120W \pm 1dB
Frequency response within -3dB : 60Hz-15kHz
Dynamic Bass Boost : DBB OFF, DBB 1, DBB 2, DBB 3 ¹⁾
Digital Sound Control : Jazz, Rock, Techno, Optimal ¹⁾
VEC Control : Cinema, Hall, Concert ¹⁾
Incredible Surround : Incr. Surround, IS off ¹⁾
Max Sound : Max Sound, Max off ¹⁾
Headphone output at 32 Ω : 15mW \pm 2dB
5mW \pm 2dB (CD mode)
Input sensitivity
Aux / CDR : 500mV / 1.0V at 600 Ω

CASSETTE RECORDER:

Number of track : 2 x 2 stereo
Tape speed : 4.76 cm/sec \pm 2%
Wow and flutter : < 0.4% DIN
Fast-wind/rewind time C60 : 130 sec
Bias system : 75kHz \pm 10kHz
Rec/Pb frequency response within 8dB : 80Hz - 12.5kHz
Signal to noise ratio Ferro : > 48dBA

COMPACT DISC:

Measurement done at output conn. of the CDC module.
Frequency response within \pm 1.5dB: 20Hz - 20kHz
Output level (in Vrms) : 550mV \pm 1dB, Z_{out} = 100 Ω
Signal/Noise ratio (A-weighted) : > 80dBA
Distortion at 1kHz : < 0.003%
Channel unbalance at 1kHz : \pm 1dB
Channel separation at 1kHz : > 60dB
De-emphasis : 0 or 15/50 mS (Switched by subcode
on the disc)
MPEG 1 Layer 3 (MP3-CD) : MPEG AUDIO
MP3-CD Bit Rate : 56-256 kbps
MP3-CD Sampling Frequencies : 32 kHz, 44.1kHz,
48kHz
Recording Format : ISO 9660
UDF format not
supported

[...] Values indicated are strictly for "Cenelec version" only

¹⁾ Frequency response in each setting is software controlled.

MEASUREMENT SETUP

Tuner FM

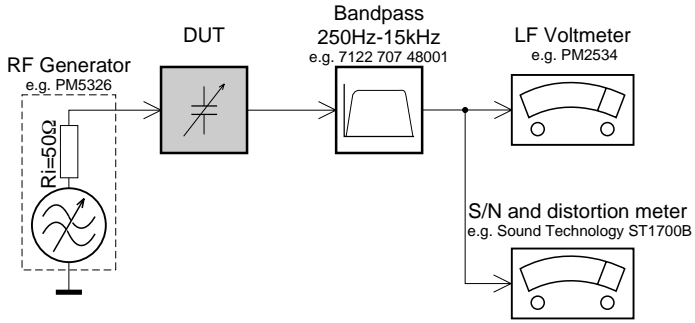

Use a bandpass filter to eliminate hum (50Hz, 100Hz) and disturbance from the pilotone (19kHz, 38kHz).

Tuner AM (MW,LW)

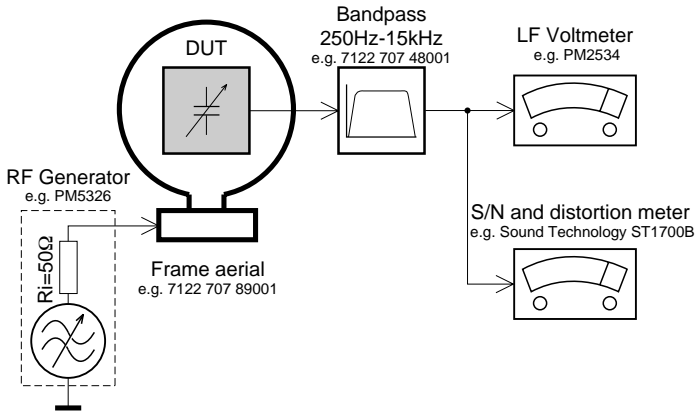

To avoid atmospheric interference all AM-measurements have to be carried out in a Faraday's cage. Use a bandpass filter (or at least a high pass filter with 250Hz) to eliminate hum (50Hz, 100Hz).

CD

Use Audio Signal Disc SBC429 4822 397 30184 (replaces test disc 3)

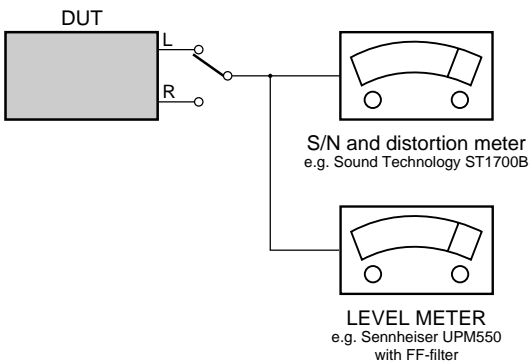

Recorder

Use Universal Test Cassette **CrO2** SBC419 4822 397 30069 or Universal Test Cassette **Fe** SBC420 4822 397 30071

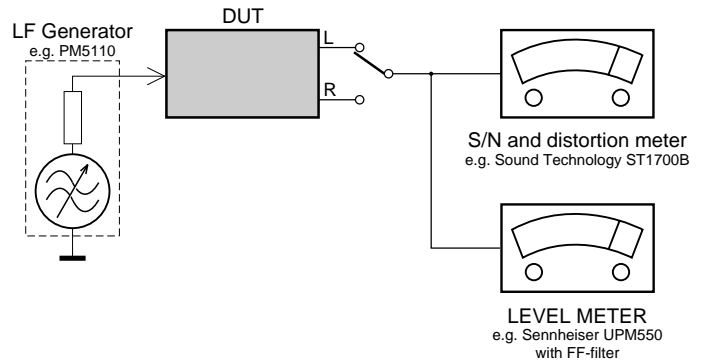

SERVICE AIDS

Service Tools:

- Universal Torx driver holder4822 395 91019
- Torx bit T10 150mm4822 395 50456
- Torx driver set T6 - T204822 395 50145
- Torx driver T10 extended4822 395 50423

Cassette:

- SBC419 Test cassette CrO24822 397 30069
- SBC420 Test cassette Fe4822 397 30071
- MTT150 Dolby level 200nWb/M 4822 397 30271

Compact Disc:

- SBC426/426A Test disc 5 + 5A4822 397 30096
- SBC442 Audio Burn-in Test disc 1kHz 4822 397 30155
- SBC429 Audio Signals disc4822 397 30184
- Dolby Pro-logic Test Disc4822 395 10216

ESD Equipment:

- Anti-static table mat - large 1200x650x1.25mm ... 4822 466 10953
- Anti-static table mat - small 600x650x1.25mm 4822 466 10958
- Anti-static wristband4822 395 10223
- Connector box (1M Ω) 4822 320 11307
- Extension cable
(to connect wristband to conn. box) 4822 320 11305
- Connecting cable
(to connect table mat to conn. box) 4822 320 11306
- Earth cable (to connect product to mat or box) 4822 320 11308
- Complete kit ESD3
(combining all above products) 4822 320 10671
- Wristband tester4822 344 13999

HANDLING CHIP COMPONENTS

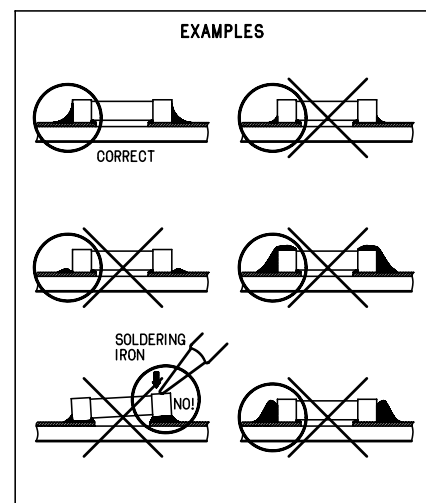
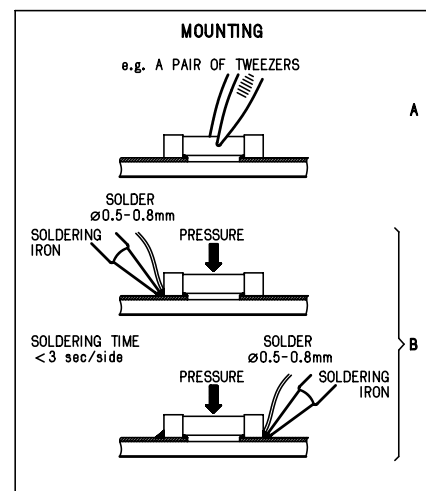
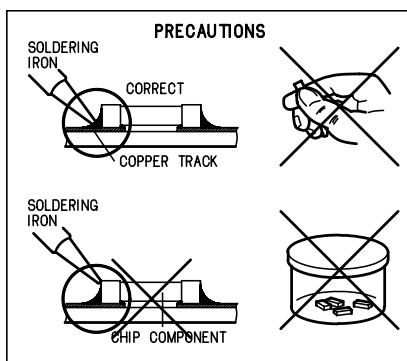
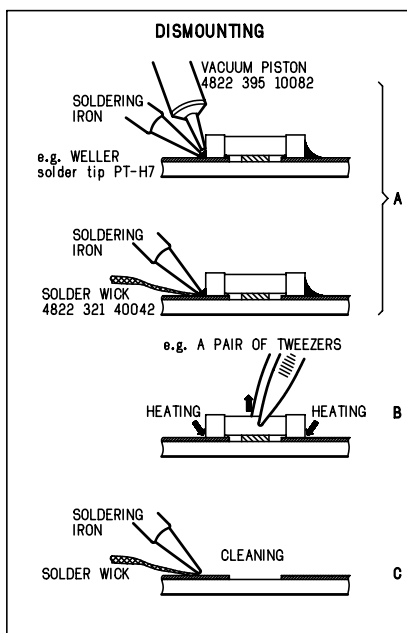
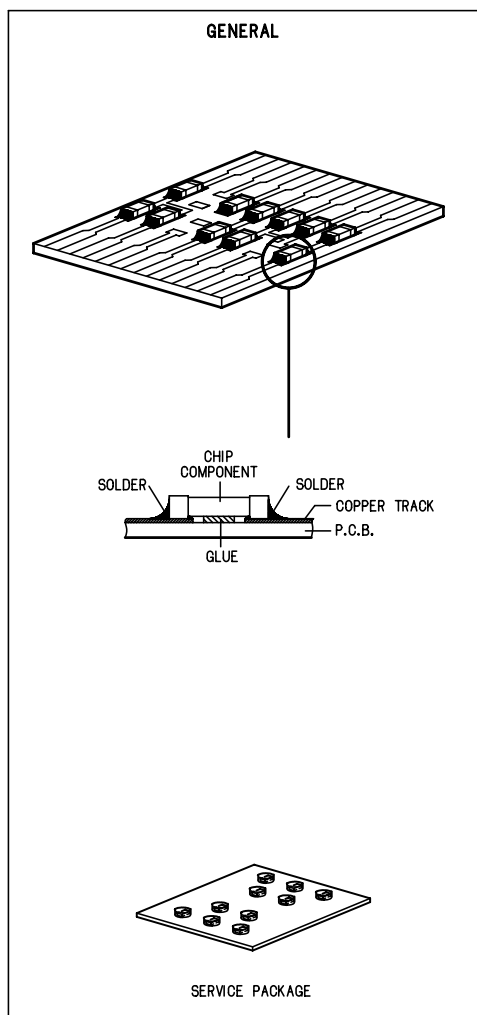

(GB) WARNING

All ICs and many other semi-conductors are susceptible to electrostatic discharges (ESD). Careless handling during repair can reduce life drastically.

When repairing, make sure that you are connected with the same potential as the mass of the set via a wrist wrap with resistance. Keep components and tools also at this potential.

ESD**(NL) WAARSCHUWING**

Alle IC's en vele andere halfgeleiders zijn gevoelig voor electrostatische ontladingen (ESD).

Onzorgvuldig behandelen tijdens reparatie kan de levensduur drastisch doen verminderen. Zorg ervoor dat u tijdens reparatie via een polsband met weerstand verbonden bent met hetzelfde potentiaal als de massa van het apparaat.

Houd componenten en hulpmiddelen ook op hetzelfde potentiaal.

(F) ATTENTION

Tous les IC et beaucoup d'autres semi-conducteurs sont sensibles aux décharges statiques (ESD).

Leur longévité pourrait être considérablement écourtée par le fait qu'aucune précaution n'est prise à leur manipulation.

Lors de réparations, s'assurer de bien être relié au même potentiel que la masse de l'appareil et enfilez le bracelet serti d'une résistance de sécurité.

Veiller à ce que les composants ainsi que les outils que l'on utilise soient également à ce potentiel.

(D) WARNUNG

Alle ICs und viele andere Halbleiter sind empfindlich gegenüber elektrostatistischen Entladungen (ESD).

Unvorsorgfältige Behandlung im Reparaturfall kann die Lebensdauer drastisch reduzieren.

Veranlassen Sie, dass Sie im Reparaturfall über ein Pulsarmband mit Widerstand verbunden sind mit dem gleichen Potential wie die Masse des Gerätes.

Bauteile und Hilfsmittel auch auf dieses gleiche Potential halten.

(I) AVVERTIMENTO

Tutti IC e parecchi semi-conduttori sono sensibili alle scariche statiche (ESD).

La loro longevità potrebbe essere fortemente ridatta in caso di non osservazione della più grande cauzione alla loro manipolazione.

Durante le riparazioni occorre quindi essere collegato allo stesso potenziale che quello della massa dell'apparecchio tramite un braccialetto a resistenza.

Assicurarsi che i componenti e anche gli utensili con quali si lavora siano anche a questo potenziale.

(GB)

Safety regulations require that the set be restored to its original condition and that parts which are identical with those specified, be used.

"Pour votre sécurité, ces documents doivent être utilisés par des spécialistes agréés, seuls habilités à réparer votre appareil en panne".

(NL)

Veiligheidsbepalingen vereisen, dat het apparaat bij reparatie in zijn oorspronkelijke toestand wordt teruggebracht en dat onderdelen, identiek aan de gespecificeerde, worden toegepast.

(F)

Les normes de sécurité exigent que l'appareil soit remis à l'état d'origine et que soient utilisées les pièces de rechange identiques à celles spécifiées.

(D)

Bei jeder Reparatur sind die geltenden Sicherheitsvorschriften zu beachten. Der Originalzustand des Geräts darf nicht verändert werden; für Reparaturen sind Original-Ersatzteile zu verwenden.

(I)

Le norme di sicurezza esigono che l'apparecchio venga rimesso nelle condizioni originali e che siano utilizzati i pezzi di ricambio identici a quelli specificati.

"After servicing and before returning set to customer perform a leakage current measurement test from all exposed metal parts to earth ground to assure no shock hazard exist. The leakage current must not exceed 0.5mA."

**(GB) Warning !**

Invisible laser radiation when open.
Avoid direct exposure to beam.

(S) Varning !

Osynlig laserstrålning när apparaten är öppnad och spärren är urkopplad. Betrakta ej strålen.

(SF) Varoitus !

Avatussa laitteessa ja suojaletkituksen ohitettaessa olet alltiina näkymättömälle laserisäteilylle. Älä katso säteeseen!

(DK) Advarse !

Usynlig laserstrålning ved åbning når sikkerhedsafbrydere er ude af funktion. Undgå udsættelse for stråling.

Preparations

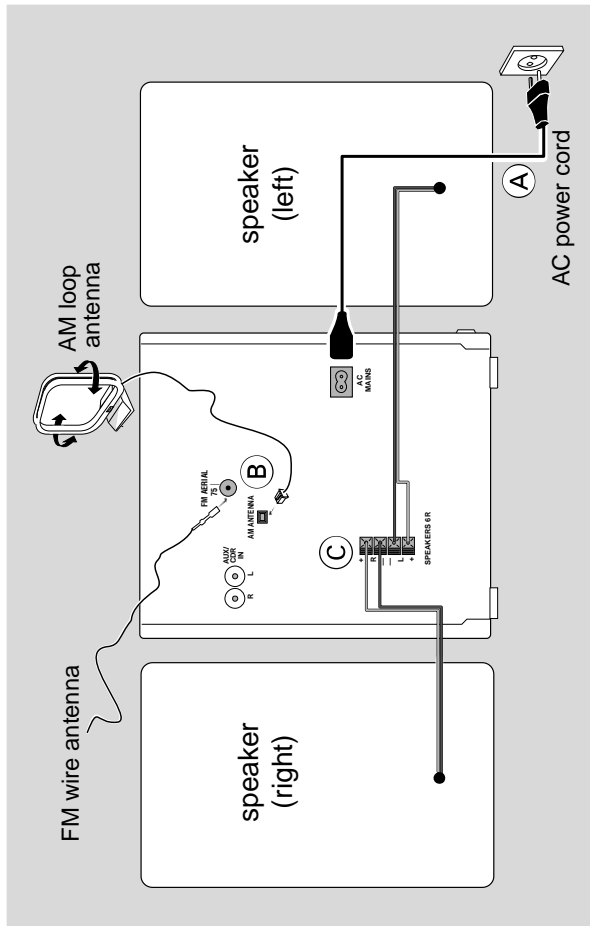

Rear connections

The type plate is located at the rear of the system.
For users in the U.K.: please follow the instructions on page 1-9.

(A) Power

Before connecting the AC power cord to the wall outlet, ensure that all other connections have been made.

WARNING!

- For optimal performance, use only the original power cable.
- Never make or change any connections with the power switched on.

To avoid overheating of the system, a safety circuit has been built in. Therefore, your system may switch to Standby mode automatically under extreme conditions. If this happens, let the system cool down before reusing it (not available for all versions).

(B) Antennas Connection

Connect the supplied AM loop antenna and FM antenna to the respective terminals. Adjust the position of the antenna for optimal reception.

AM Antenna

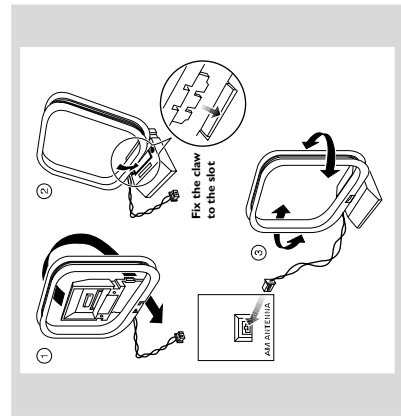

Position the antenna as far as possible from a TV, VCR or other radiation source.

FM Antenna



For better FM stereo reception, connect an outdoor FM antenna to the FM ANTENNA terminal.

(C) Speakers Connection

Front Speakers

Connect the speaker wires to the SPEAKERS terminals, right speaker to "R" and left speaker to "L", coloured (marked) wire to "+" and black (unmarked) wire to "-".

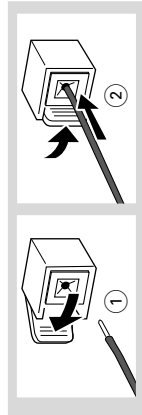

Fully insert the stripped portion of the speaker wire into the terminal as shown.

Notes:

- For optimal sound performance, use the supplied speakers.
- Do not connect more than one speaker to any one pair of + / - speaker terminals.
- Do not connect speakers with an impedance lower than the speakers supplied. Please refer to the SPECIFICATIONS section of this manual.

Preparations

Optional connection

The optional equipment and connecting cords are not supplied. Refer to the operating instructions of the connected equipment for details.

Connecting other equipment to your system

Use a cinch cable to connect **AUX/CDR IN** to the analogue audio out terminals of an external equipment (TV, VCR, Laser Disc player, DVD player or CD Recorder).

Note:

- If you are connecting equipment with a mono output (a single audio out terminal), connect it to the **AUX/CDR IN** left terminal. Alternatively, you can use a "single to double" cinch cable (the output sound still remain mono).

Inserting batteries into the remote control

Insert two batteries (Type R06 or AA) into the remote control with the correct polarity as indicated by the "+" and "-" symbols inside the battery compartment.

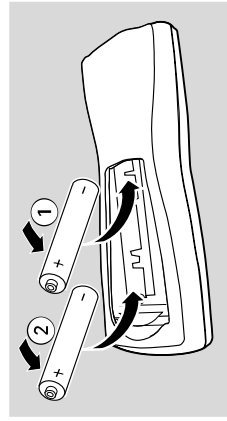

CAUTION!

- Remove batteries if they are exhausted or will not be used for a long time.
- Do not use old and new or different types of batteries in combination.
- Batteries contain chemical substances, so they should be disposed off properly.

PREPARATIONS AND CONTROLS

Controls

Controls on the system and remote control

- ① **STANDBY ON** ϕ
to switch the system on or to standby mode.
- ② **ECO POWER**
to switch the system on or to Eco Power standby mode.
- ③ **DISC 1/2/3 (CD DIRECT 1/2/3)**
to select a disc tray for playback.
- ④ **Source selection** – to select the following:
CD (CD 1•2•3)
to select disc tray 1, 2 or 3.
TUNER (BAND)
to select waveband : FM, MW or LW.
TAPE (TAPE 1•2)
to select tape deck 1 or 2.
AUX (VIDEO/CDR)
to select the input for an additional appliance : AUX or CDR.

⑤ Mode Selection

- ◀▶ SEARCH•TUNING (▼ALBUM▲)**
for MP3-CD to select previous/next album.
for CD to search backward/forward.
for Tuner to tune to a lower or higher radio frequency.
for Tape to rewind or fast forward.
for Clock (on the system only) to set the hour.

■ STOP•CLEAR (DEMO STOP)

- for CD/ MP3-CD .. to stop playback or to clear a programme.
- for Tuner (on the system only) to stop programming.
- for Tape to stop playback or recording.
- for Demo (on the system only) to activate/deactivate the demonstration.
- for Clock (on the system only) to exit clock setting or cancel timer.
- for Plug & Play (on the system only) to exit plug & play mode.

▶ II PLAY•PAUSE

- for CD/ MP3-CD .. to start or interrupt playback.
- for Tape to start playback.
- for Plug & Play (on the system only) to initiate and start plug & play mode.

◀ PREV / ▶ NEXT (– TITLE +)

- for MP3-CD to select previous/next title.
- for CD to skip to the beginning of the current, previous, or next track.

for Tuner

- to select a preset radio station.
- for Clock (on the system only) to set the minute.

⑥ SOUND NAVIGATION

- to select and activate the JOG control for the desired sound feature : DBB, DSC or VEC.

⑦ JOG

- to select the desired sound effect for the selected sound feature.

DBB

- DBB 1, DBB 2 or DBB 3.

DSC

- OPTIMAL, JAZZ, ROCK or TECHNO.

VEC

- CINEMA, HALL or CONCERT.

⑧ INCREDIBLE SURROUND (INC. SURR.)

- to activate or deactivate the surround sound effect.

⑨ CLOCK•TIMER (CLK/TIMER)

- to view the clock.
- to set the clock or set the timer (on the set only).

⑩ Tape Deck Operation

RECORD

- to start recording on tape deck 2.

DUBBING

- to dub a tape.

⑪ Tape deck 1

⑫ Tape deck 2

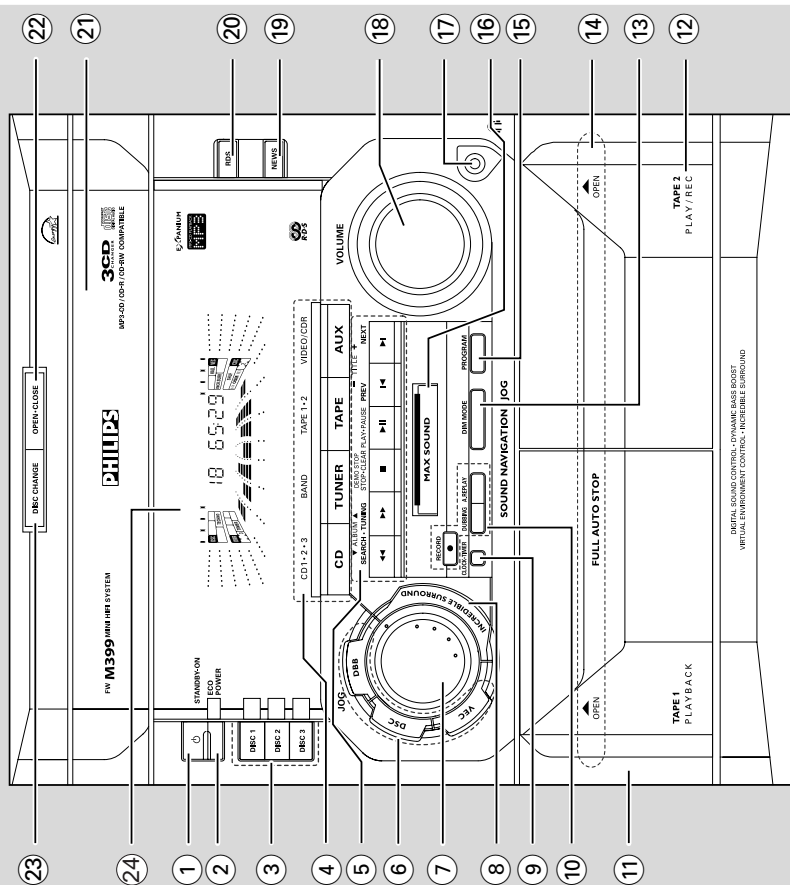
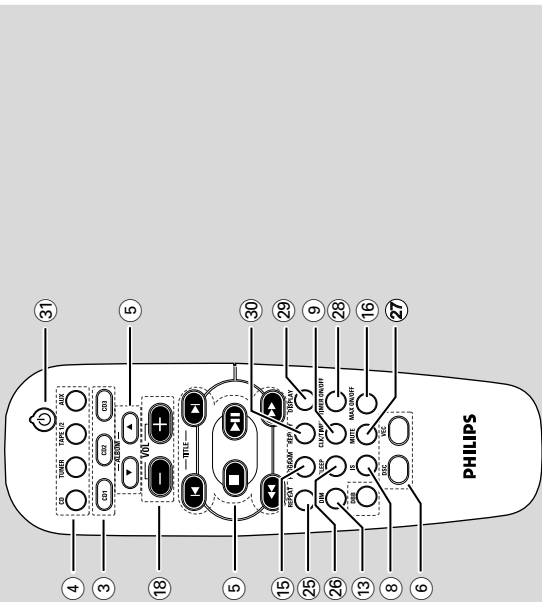

Controls

- 13 DIM MODE**
to select different brightness for the display screen : DIM 1, DIM 2, DIM 3 or DIM OFF.
- 14** **OPEN**
to open the tape deck door.
- 15 PROGRAM**
for CD to programme disc tracks.
for Tuner to programme preset radio stations.
for Clock to select 12- or 24-hour clock mode.
- 16 MAX SOUND (MAX)**
to activate or deactivate the optimal mix of various sound features.
- 17**
to connect headphones.
- 18 VOLUME (VOLUME +/-)**
to increase or decrease the volume.
- 19 NEWS**
to hear News automatically.
- 20 RDS**
to select RDS information.
- 21 Disc tray**
- 22 OPEN•CLOSE**
to open or close the disc tray.
- 23 DISC CHANGE**
to change disc(s).
- 24 Display screen**
to view the current status of the system.
- 25 REPEAT**
to playback track(s)/disc(s)/programme repeatedly.
- 26 SLEEP**
to activate/deactivate or set the sleep timer.
- 27 SHUFFLE**
to playback all available discs and their tracks/programme in random order.
- 28**
to switch the system to standby mode.
to switch the system to Eco Power standby mode.
- Notes for remote control:**
– **First, select the source you wish to control by pressing one of the source select keys on the remote control (CD or TUNER, for example).**
– **Then select the desired function (▶, ◀, ⏪, ⏩, for example).**

Important notes for users in the U.K.

Mains plug

This apparatus is fitted with an approved 13 Amp plug. To change a fuse in this type of plug proceed as follows:

- 1** Remove fuse cover and fuse.
- 2** Fix new fuse which should be a BS1362 5 Amp, A.S.T.A. or BSI approved type.
- 3** Refit the fuse cover.

If the fitted plug is not suitable for your socket outlets, it should be cut off and an appropriate plug fitted in its place.

If the mains plug contains a fuse, this should have a value of 5 Amp. If a plug without a fuse is used, the fuse at the distribution board should not be greater than 5 Amp.

Note: These vered plug must be disposed of to avoid a possible shock hazard should it be inserted into a 13 Amp socket else where.

How to connect a plug

The wires in the mains lead are coloured with the following code: blue = neutral (N), brown = live (L).

- As these colours may not correspond with the colour markings identifying the terminals in your plug, proceed as follows:
 - Connect the blue wire to the terminal marked N or coloured black.
 - Connect the brown wire to the terminal marked L or coloured red.
 - Do not connect either wire to the earth terminal in the plug, marked E (or ⚡) or coloured green (or green and yellow).

Before replacing the plug cover, make certain that the cord grip is clamped over the sheath of the lead - not simply over the two wires.

Copyright in the U.K.

Recording and playback of material may require consent. See Copyright Act 1956 and The Performer's Protection Acts 1958 to 1972.

Italia

DICHIARAZIONE DI CONFORMITA'

Si dichiara che l'apparecchio FVW-C717 Philips risponde alle prescrizioni dell'art. 2 comma 1 del D.M. 28 Agosto 1995 n. 548.

Fatto a Eindhoven

Philips Consumer Electronics
Philips, Glaslaan 2
5616 JB Eindhoven, The Netherlands

Norge

Typeskilt finnes på apparatens underside.

Observed: Netthytteren er sekundært innkoplet. Den innebygde nettdelen er derfor ikke frakoplet nettet så lenge apparatet er tilsluttet nettkontaktene.

For å redusere faren for brann eller elektrisk støt, skal apparatet ikke utsettes for regn eller fuktighet.

CAUTION

Use of controls or adjustments or performance of procedures other than herein may result in hazardous radiation exposure or other unsafe operation.

Cleaning the Cabinet

Use a soft cloth slightly moistened with a mild detergent solution. Do not use a solution containing alcohol, spirits, ammonia or abrasives.

Cleaning Discs

When a disc becomes dirty, clean it with a cleaning cloth. Wipe the disc from the centre out.

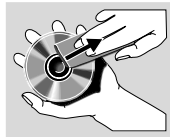

Do not use solvents such as benzene, thinner, commercially available cleaners, or antistatic spray intended for analogue records.

Cleaning the disc lens

After prolonged use, dirt or dust may accumulate at the disc lens. To ensure good playback quality, clean the disc lens with Philips CD Lens Cleaner or any commercially available cleaner. Follow the instructions supplied with cleaner.

Cleaning the Heads and the Tape Paths

To ensure good recording and playback quality, clean the heads (A), the capstan(s) (B), and pressure roller(s) (C) after every 50 hours of tape operation.

Use a cotton swab slightly moistened with cleaning fluid or alcohol. You can also clean the heads by playing a cleaning tape once.

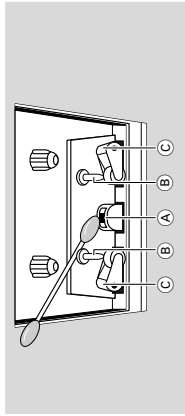

Demagnetising the heads

Use a demagnetising tape available at your dealer.

RADIO RECEPTION

Radio reception is poor

- If the signal is too weak, adjust the antenna or connect an external antenna for better reception.
- Increase the distance between the Mini HiFi System and your TV or VCR.

TAPE OPERATION/RECORDING

Recording or playback cannot be made.

- Clean deck parts, see "Maintenance".
- Use only NORMAL (IEC I) tape.
- Apply a piece of adhesive tape over the missing tab space.

The tape deck door cannot open.

- Remove and reconnect the AC power plug and switch on the system again.

GENERAL

The system does not react when buttons are pressed.

- Remove and reconnect the AC power plug and switch on the system again.

Sound cannot be heard or is of poor quality.

- Adjust the volume.
- Disconnect the headphones.
- Check that the speakers are connected correctly.
- Check if the stripped speaker wire is clamped.
- Check the speaker connections and location.

The left and right sound outputs are reversed.

- Check the speaker connections and location.

The remote control does not function properly.

- Select the source (CD 1/2/3 or TUNER, for example) before pressing the function button (▶, ◀, ►, ◀▶).
- Reduce the distance between the remote control and the system.
- Insert the batteries with their polarities (+/- signs) aligned as indicated.
- Replace the batteries.
- Point the remote control directly towards the IR sensor.

The timer is not working.

- Set the clock correctly.
- Press and hold CLOCK•TIMER to switch on the timer.
- If recording or tape dubbing is in progress, stop recording.

Not all lighted buttons are showing light.

- Press DIM to select DIM OFF display mode.

The Clock/Timer setting is erased.

- Power has been interrupted or the power cord has been disconnected. Reset the clock/timer.

The system displays features automatically

- Press and hold ■ on the system to switch off the demonstration.

WARNING

Under no circumstances should you try to repair the system your self, as this will invalidate the warranty. Do not open the system as there is a risk of electric shock.

If a fault occurs, first check the points listed below before taking the system for repair. If you are unable to solve a problem by following these hints, consult your dealer or service centre.

Problem

Solution

CD OPERATION

"NO DISC" is displayed.

- Insert a disc.
- Check if the disc is inserted upside down.
- Wait until the moisture condensation at the lens has cleared.
- Replace or clean the disc, see "Maintenance".
- Use a finalised CD-RW or CD-R.

"DISC NOT FINALIZED" is displayed.

DISMANTLING INSTRUCTIONS

Dismantling of the Cassette Cover

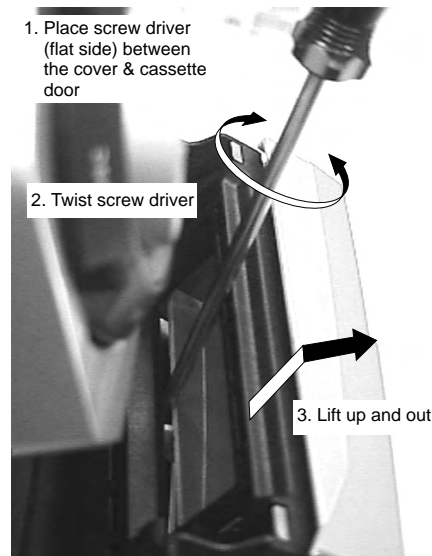

Figure 1

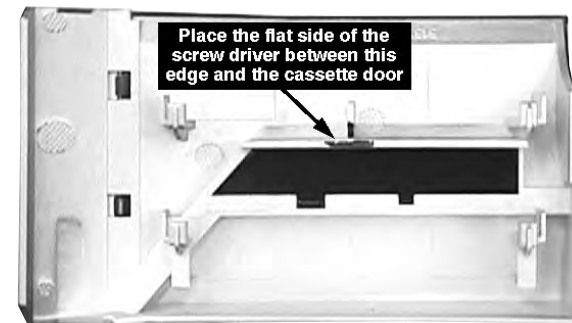

Figure 2

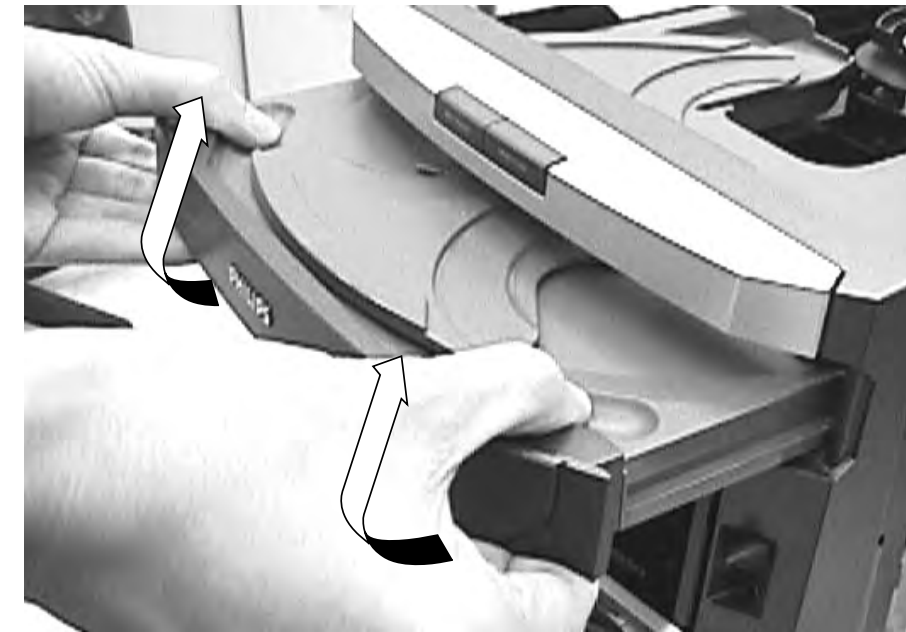

Figure 4

Dismantling the 3CDC Module and Tuner Board

- 1) Loosen the 4 screws, slide Cover top (pos 255) towards the rear and remove it upwards.
- 2) Loosen 3 screws, slide the Panel right (pos 254) towards the rear and remove it outwards. Do likewise for the Panel left (pos 253).
- 3) Push the gear slowly towards the front as shown in figure

3 until the CDC tray starts to move out of the Front Cabinet (pos 101). The CDC tray is now disengaged and can be pulled out completely.

- 4) Remove the Cover Tray (pos 106) as shown in figure 4.
- 5) Loosen 4 screws A to remove the CDC Module (pos 1105) as shown in figure 3.
- 6) Loosen 3 screws N (see figure 10) on the Panel Rear (pos 256) and release 2 catches C1 to remove the Tuner Board.

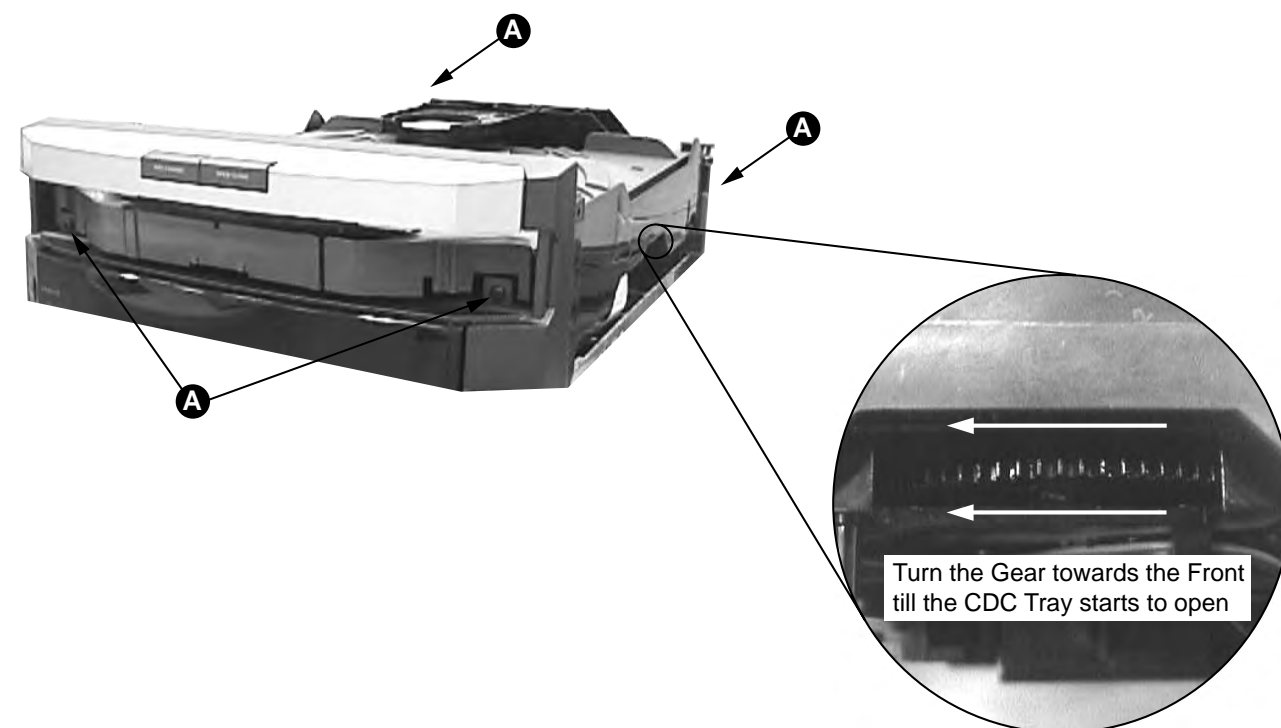

Figure 3

Dismantling of the Cover Front Display (pos 129) and Cover Front Ornamental (pos 130)

- 1) Cut a piece of packaging tape approximately 5cm width by 12cm length and tape its narrow side on to the top and bottom side of the Volume knob (pos 139) as shown in figure 5.
- 2) Place a small screw driver in between the tape & knob (see figure 5) to give more leverage in pulling out the knob as shown in figure 6.
- 3) Do likewise for the Jog Rotary knob (pos 138). You may have to rotate the knob to provide the most exposed area during application of the packaging tape.
- 4) Remove the Button Sound Control & Lightguide assembly (pos 136 & 140) by releasing 3 catches.

- 5) Remove the 2 screws behind the knobs' locations and release 4 catches to detach the Cover Front Display (pos 129).
- 6) Release 4 catches to detach the Cover Front Ornamental (pos 130).

Notes: *There is nothing are sandwiched between the Front Cabinet (pos 101) and Cover Front Display (pos 129) but it has to be removed in order to reach the catches for the Cover Front Ornamental (pos 130).*



Figure 5

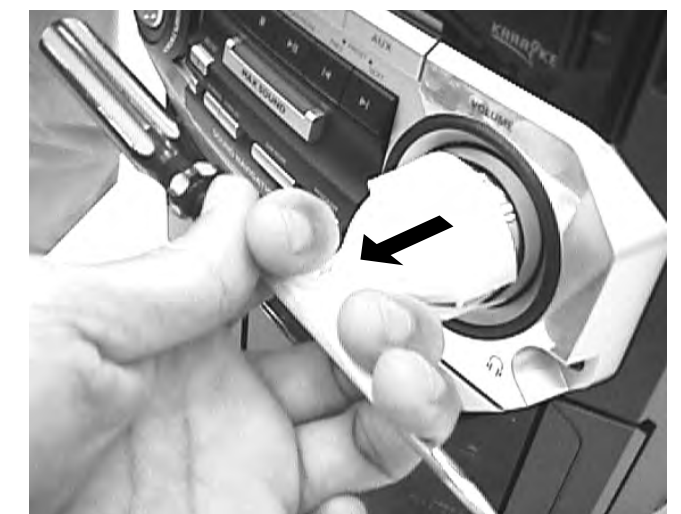

Figure 6

Detaching the AF9 board and Front Cabinet Assembly from the Bottom/Rear assembly

- 1) Release 2 catches C2 to free the AF9 board from the Front Cabinet Assembly as shown in figure 7.
- 2) Loosen 1 screw M on the Rear panel (pos 256) to remove the AF9 board as shown in figure 10.
- 3) Loosen 2 screws C at the bottom of the Front Cabinet on both sides of the set.
- 4) Release 2 catches C3 on both sides of the Front Cabinet (pos 101) and pull the Front Cabinet assembly out of the Bottom plate (pos 265).

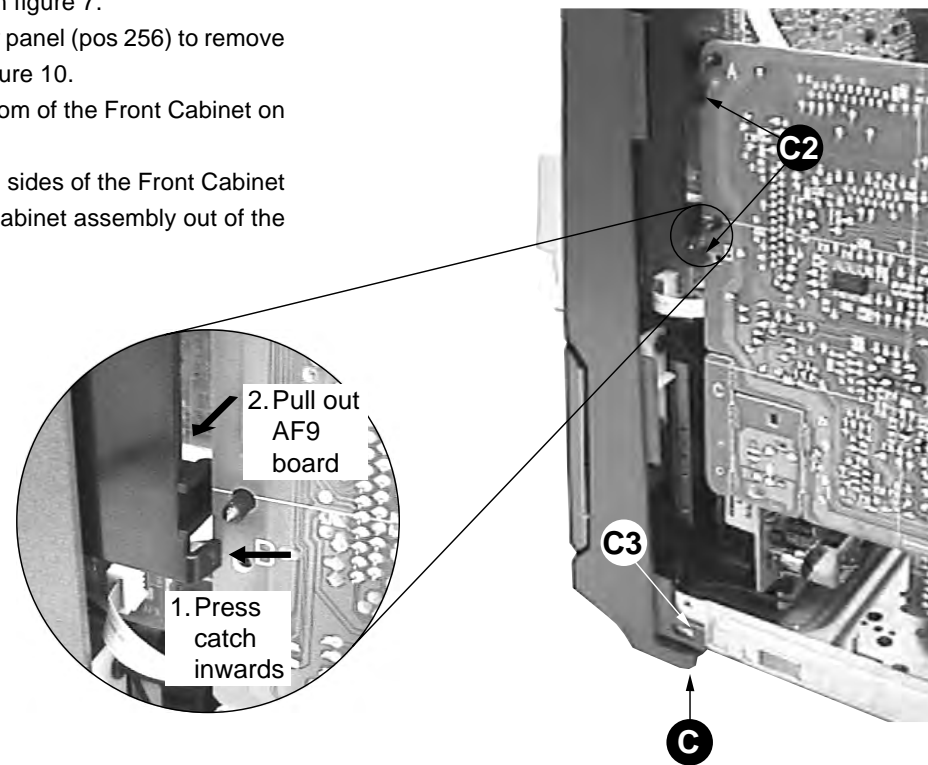

Figure 7

Dismantling of the Rear Panel

- 1) Loosen 5 screws H as shown in figure 10.
- 2) Release 2 catches C4 on the Mains Socket body to free the Mains Socket board.
- 3) Release 2 catches C5 on both sides of the Rear Panel (pos 256) with the help of a minus screw driver and pull out the Rear Panel.

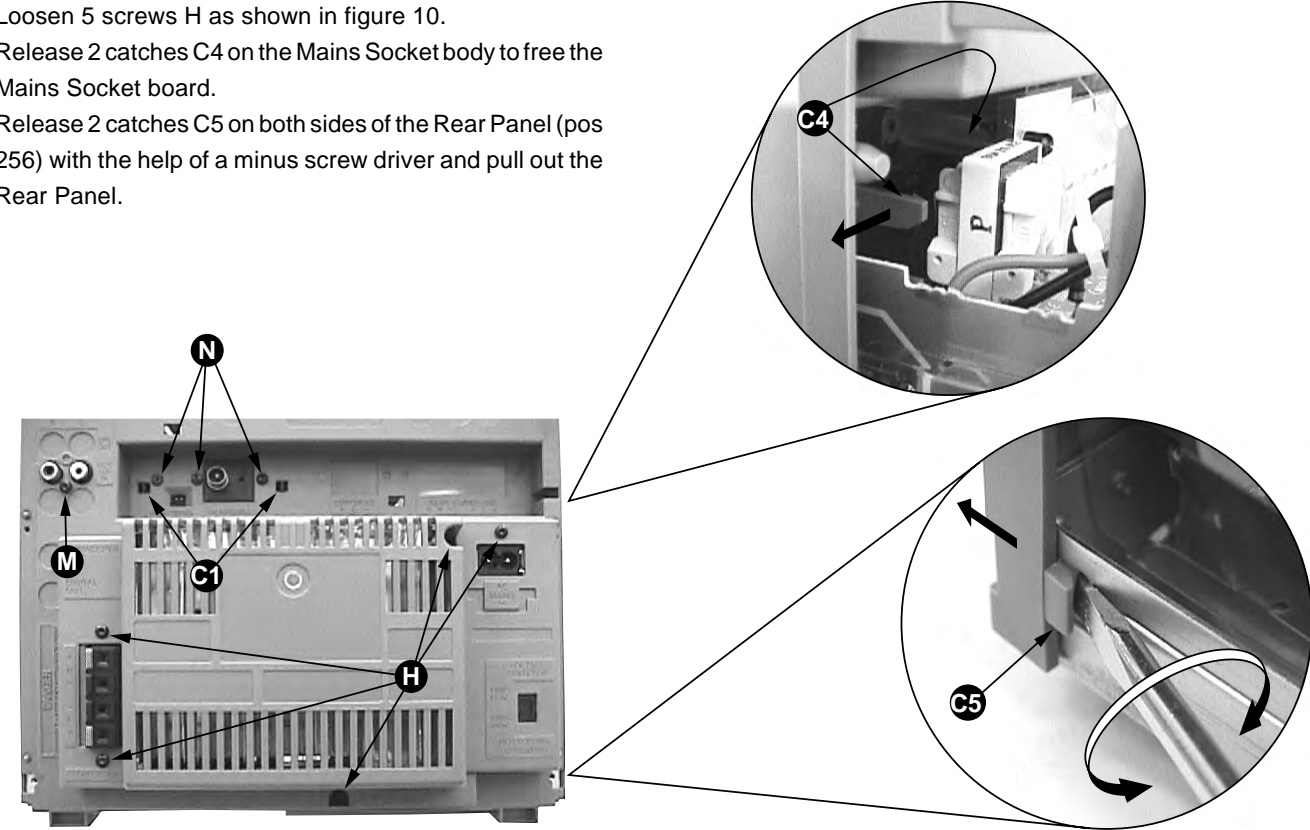

Figure 10

Dismantling of the Front Board and ETF7 module

- 1) Remove the Jog and Volume knobs (pos 138 & 139) as stated in Dismantling the Cover Front Display.
- 2) Loosen 3 screws D to remove the Bracket CDC Right (pos 252) as shown in figure 8.
- 3) Loosen 3 screws E to remove the Karaoke board and Headphone board.
- 4) Loosen 11 screw F to remove the Front Board.
- 5) Loosen 6 screws G to remove the ETF7 Module (pos 1104).

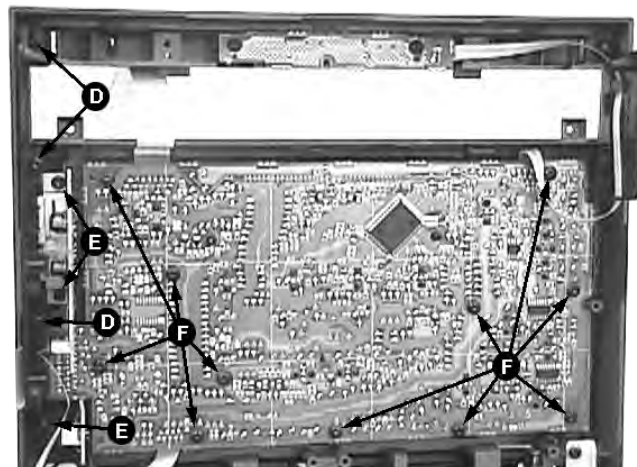

Figure 8

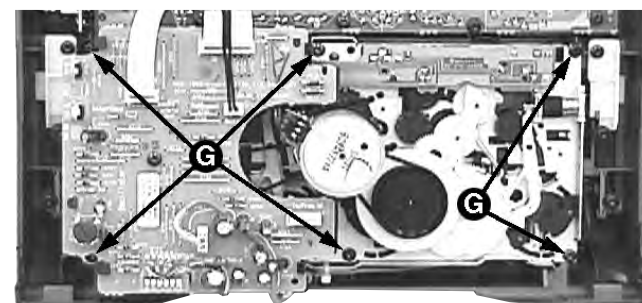

Figure 9

Dismantling of the Bottom assembly

- 1) Loosen 2 screws J and lift-up the Power Board / Heatsink assembly from the Bottom plate (pos 265) as shown in figure 11.
- 2) Loosen 2 screws K to remove the Fan / Bracket assembly as shown in figure 12.
- 3) Loosen 4 screws L for the Mains Transformer to remove the Mains Transformer / Mains Board assembly.

Note: During re-assembly care should be taken to ensure the fan blade and wires are in the right direction and position.

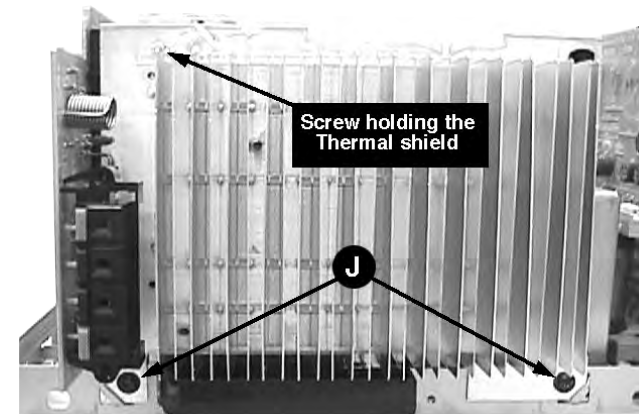

Figure 11

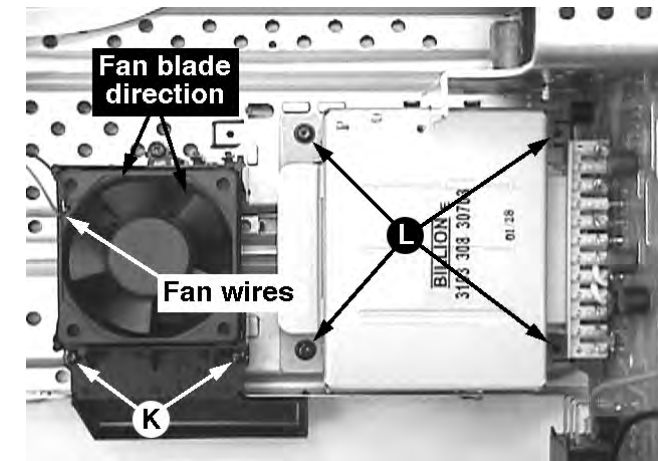
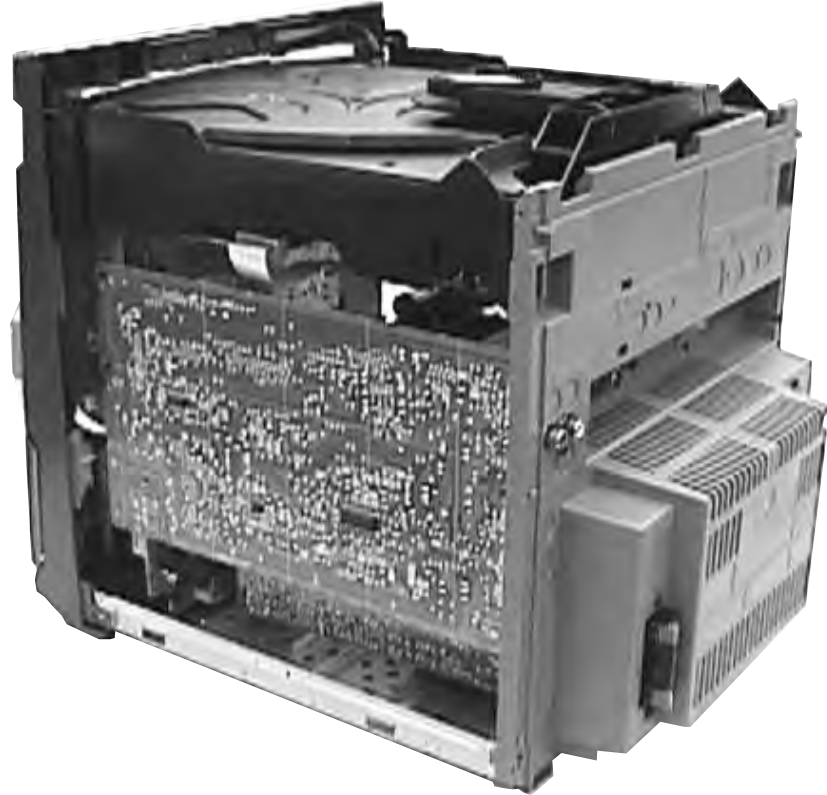

Figure 12

Service positions

Service position A



Service position C

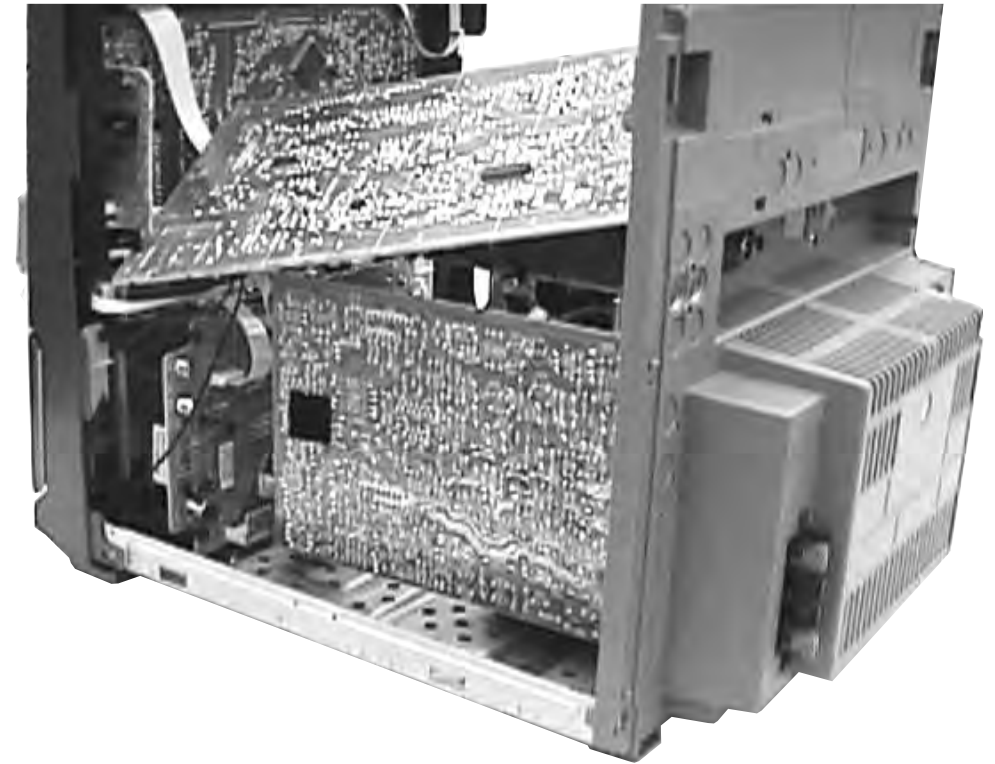

Note: After re-assembly, it is very important to ensure the wires are properly inserted into their respective sockets and routed not to touch or obstruct any moving parts.

Service position B

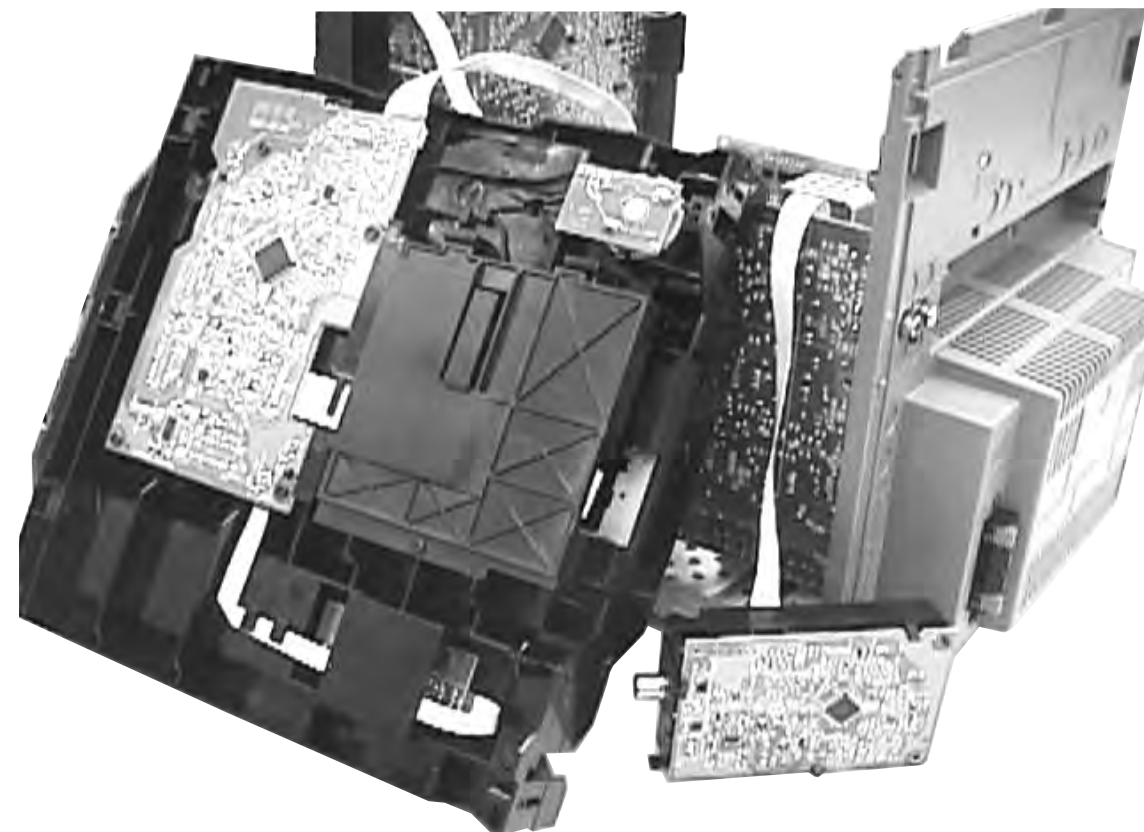

Service position D

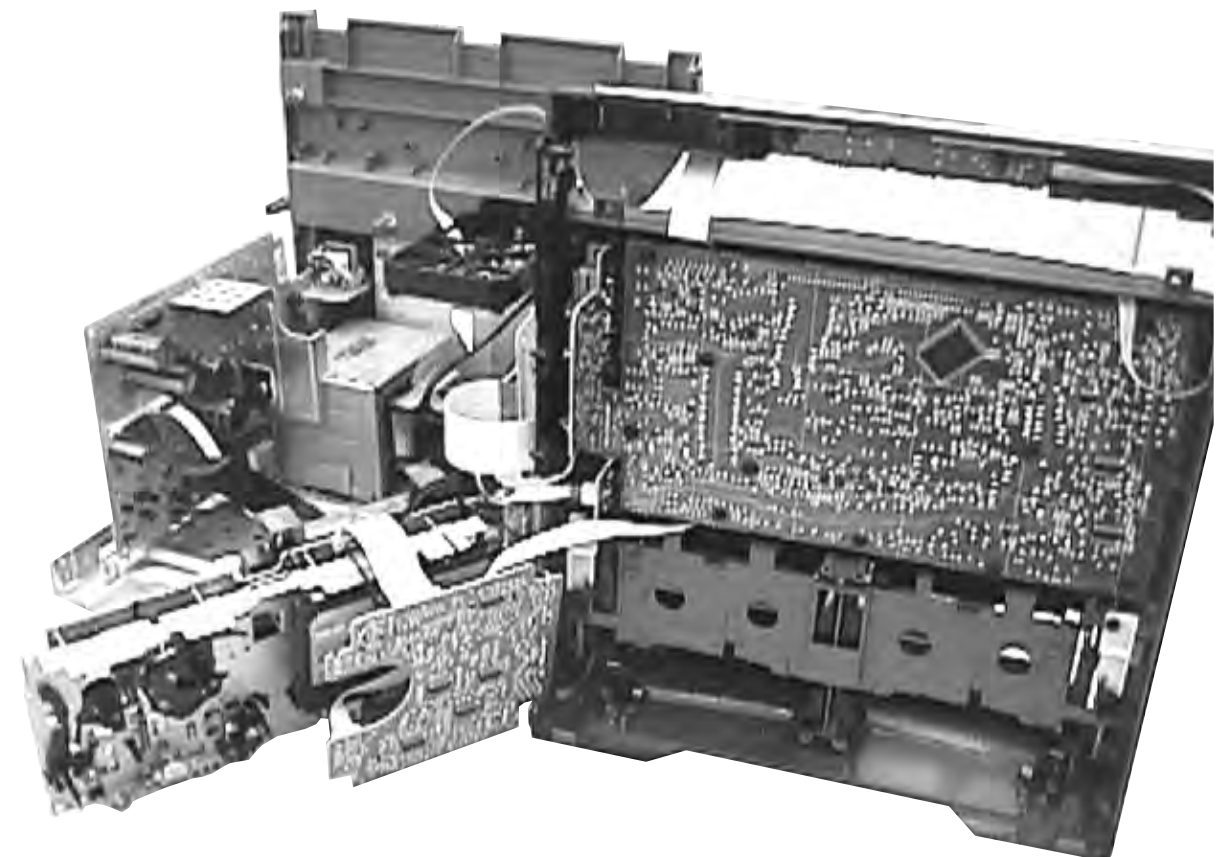

SERVICE TEST PROGRAM

DEMO Mode

To start service test program hold **▶** & **AUX** depressed while plugging in the mains cord

Display shows the ROM version * "S-Vyy" (Main menu)

S refers to Service Mode.
V refers to Version.
yy refers to Software version number of Processor. (Counting up from 01 to 99)

	ACTION
To Switch off	Hold the ■ button down for 5 seconds during the DEMO display, the set will confirm with "DEMO OFF" and switch to Standby.
To Switch on	Hold the ■ button down for 5 seconds during Standby, DEMO will begin.

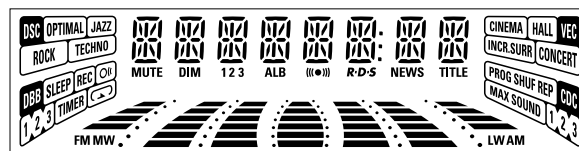
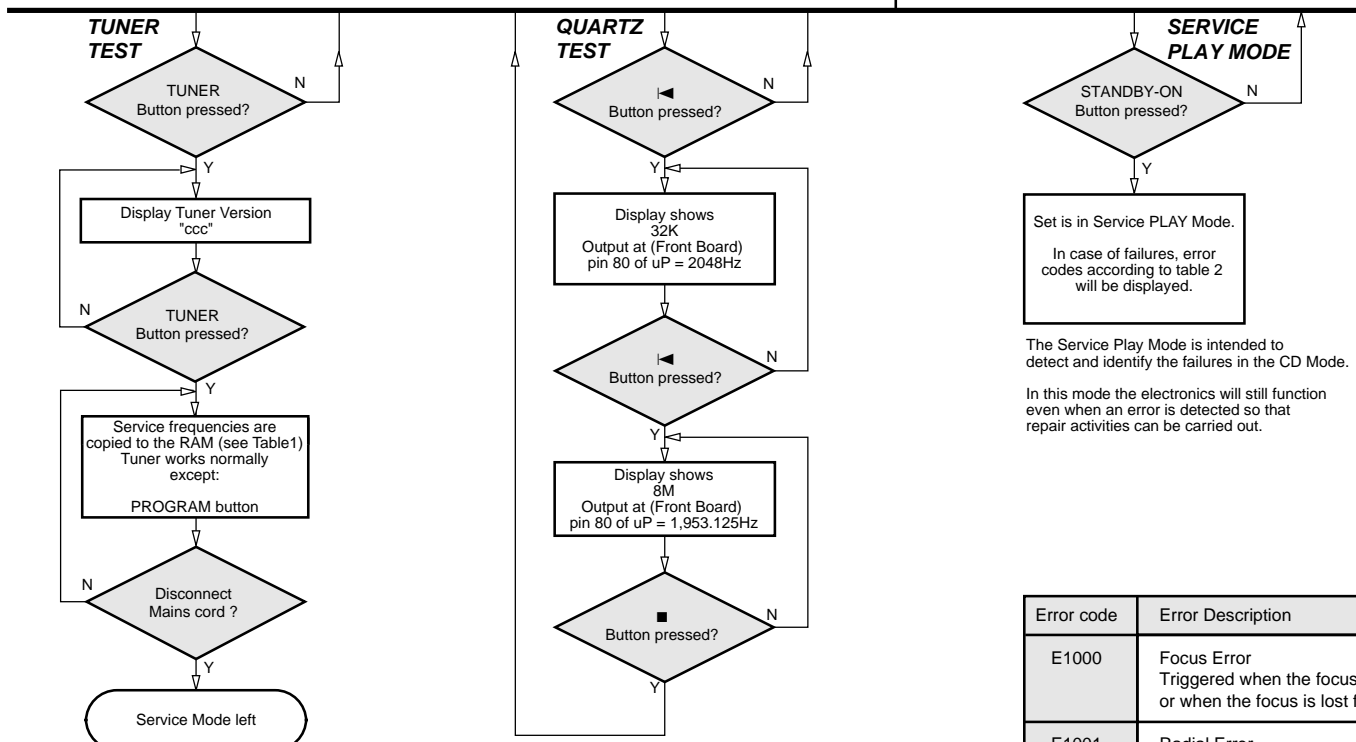

note 1: All LEDs are on except ECO POWER.

Figure 1

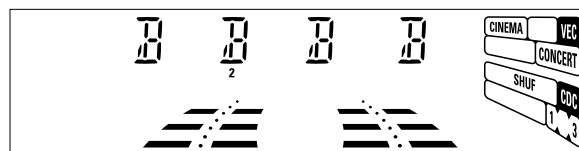

note 2: Only DISC 2, TUNER, AUX, DSC, VEC & MAX SOUND are on.

Figure 2

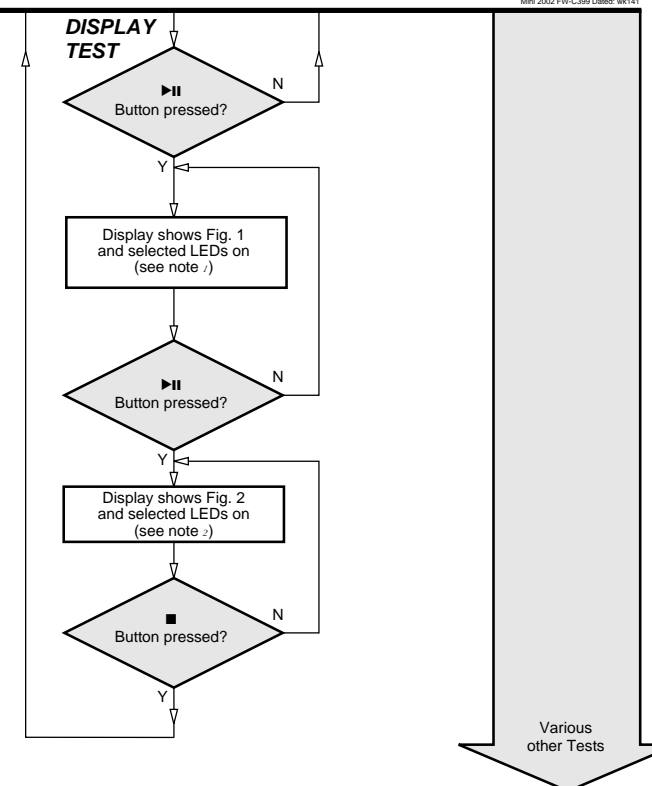

PRESET	Europe "EUR"	East Eur. Extended-band "EAS"	East Eur. "EAS"	USA "USA"	Oversea "OSE"
1	87.5MHz	65.81MHz	87.5MHz	87.5MHz	87.5MHz
2	108MHz	108MHz	108MHz	108MHz	108MHz
3	531kHz	74MHz	531kHz	530kHz	530/531kHz*
4	1602kHz	87.5MHz	1602kHz	1700kHz	1700/1602kHz*
5	558kHz	531kHz	558kHz	560kHz	560/558kHz*
6	1494kHz	1602kHz	1494kHz	1500kHz	1500/1494kHz*
7	153kHz	558kHz	87.5MHz	98MHz	98/87.5MHz*
8	279kHz	1494kHz	87.5MHz	87.5MHz	87.5MHz
9	198kHz	98MHz	87.5MHz	87.5MHz	87.5MHz
10	98MHz	70.01MHz	87.5MHz	87.5MHz	87.5MHz
11	87.5MHz	65.81MHz	98MHz	87.5MHz	87.5/98MHz*

Table 1

Note: * Depending on the selected grid frequency (9 or 10kHz)
By holding the TUNER and **▶▶** buttons depressed while switching on the Mains supply, one of the undermentioned features will be activated:
- the tuning grid frequency is toggled between 9kHz and 10kHz for the Oversea (/21) version.
- the extended FM1 (65.81MHz - 74MHz) is toggled on and off for East Eur. (/34) version.

Error code	Error Description
E1000	Focus Error Triggered when the focus could not be found within a certain time when starting up the CD or when the focus is lost for a certain time during play.
E1001	Radial Error Triggered when the radial servo is off-track for a certain time during play.
E1002	Sledge In Error The sledge did not reach its inner position (inner-switch is still close) before approximately 6 Sec. have passed by. Inner-switch or sledge motor problem.
E1003	Sledge Out Error The sledge did not come out of its inner position (inner-switch is still open) before approximately 250 mSec. have passed by. Inner-switch or sledge motor problem.
E1005	Jump-offtrack error Triggered in normal play when the jump destination could not be found within a certain time. When this error occurred, software will try to recover by initiating the jump command again. If it is recoverable, the disc will continue to play.
E1006	Subcode Error Triggered when a new subcode was missing for a certain time during play.
E1007	PLL Error The Phase Lock Loop could not lock within a certain time.
E1008	Turntable Motor Error Generated when the CD could not reached 75% of speed during startup within a certain time. Discmotor problem.
E1020	Focus Search Error The focus point has not been found within a certain time.
E1070	This happens when the carousel switch is defective and closed all the time, or when the carousel is blocked when it is located exactly at a disc position.
E1071	This happens when the carousel switch is defective and does not closed electrically, or when the carousel is blocked in between two disc positions. The time-out is approximately 5 Sec.
E1079	The drawer could not open or enter the inside position and is opening again. This happen when the drawer is blocked and cannot go fully inside or when the drawer switch is defective and does not close.

Table 2

TEST	Activated with	ACTION
EEPROM TEST	▶▶ ■ to Exit	A test pattern will be sent to the EEPROM. "PASS" is displayed if the uProcessor read back the test pattern correctly, otherwise "FAIL" will be displayed.
EEPROM FORMAT	◀◀	Load default data. Display shows "NEW" for 1 second. Caution! All presets from the customer will be lost!!
ROTARY ENCODER TEST	Volume Knob or Jog Shuttle knob	Display shows value for 2 seconds. Values increases or decreases in steps of 1 until 0 (Min.) or 40 (Max.) is reached.
LEAVE SERVICE TESTPROGRAM	Disconnect mains cord	

SET BLOCK DIAGRAM

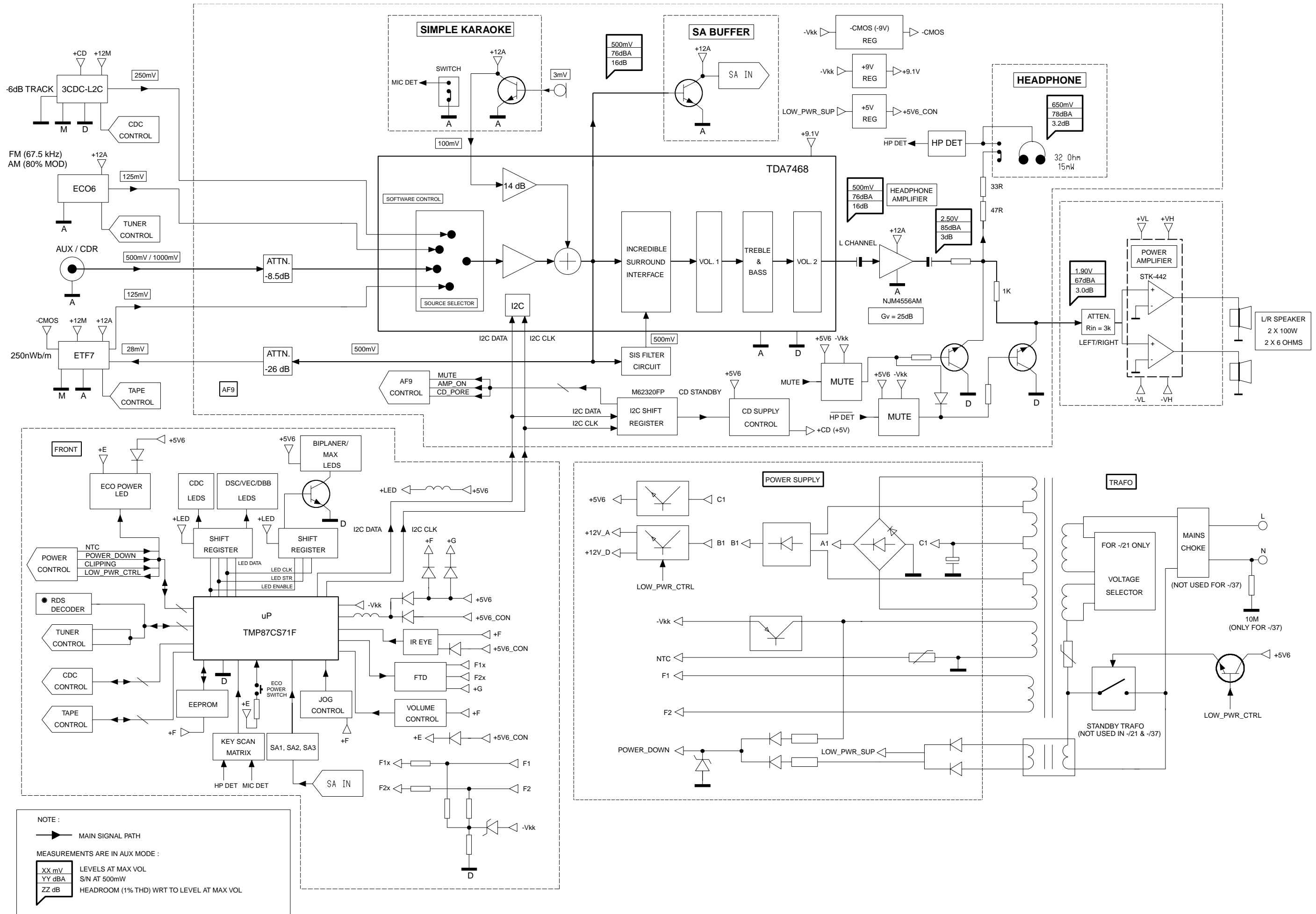

NOTE :

➔ MAIN SIGNAL PATH

MEASUREMENTS ARE IN AUX MODE :

XX mV	LEVELS AT MAX VOL
YY dBA	S/N AT 500mV
ZZ dB	HEADROOM (1% THD) WRT TO LEVEL AT MAX VOL

SET WIRING DIAGRAM

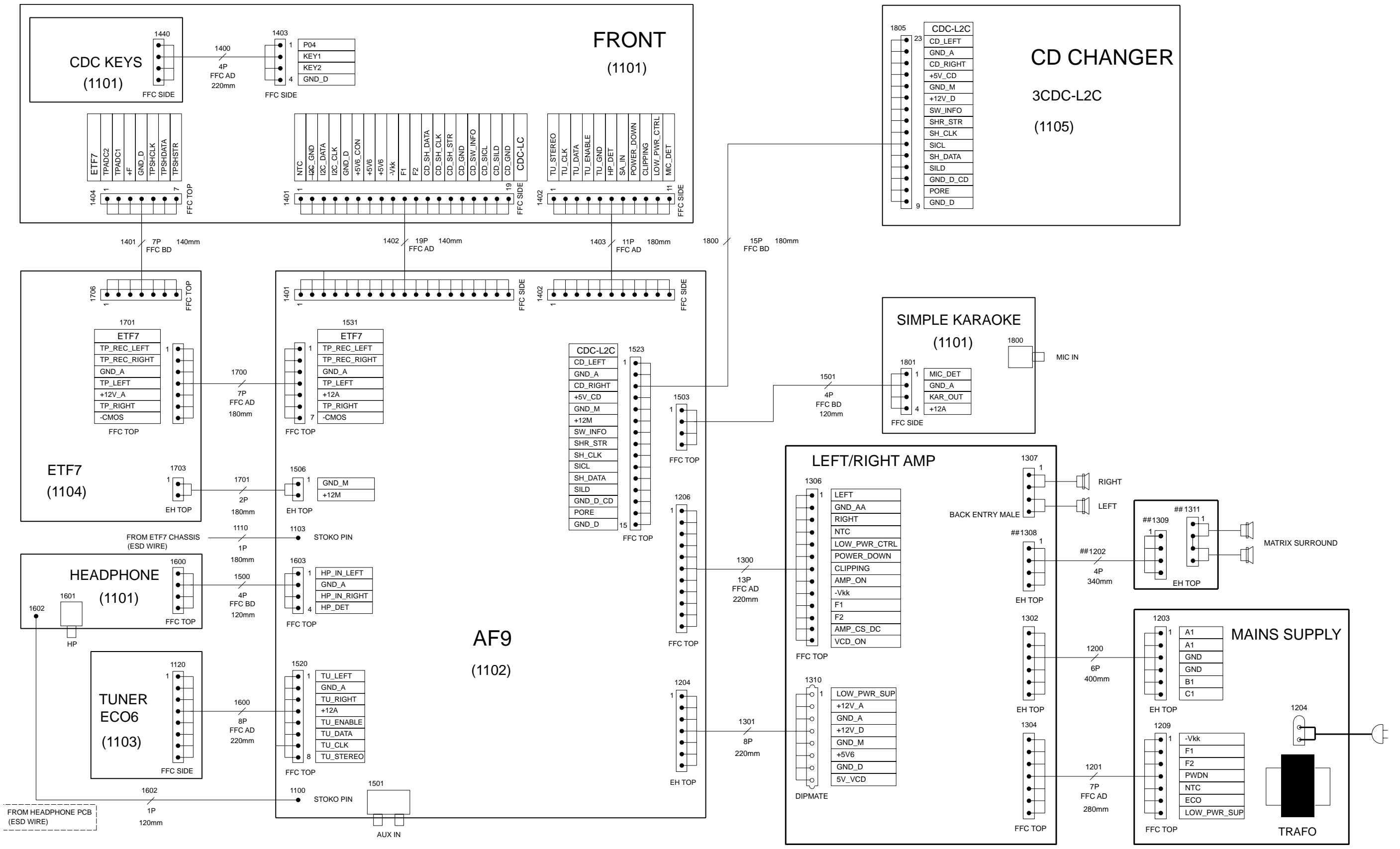

VARIATION TABLE

Item No / Features	FWM399/30	FWM399/21	FWM399/22/25
RDS / News	-	-	x
Simple Karaoke	-	x	-
Mic Detect	-	x	-
1409	x	x	x
1424	-	-	-
1425	-	-	x
1427	-	-	x
1437	-	-	-
3486	1k	1k	1k
3511	10k	10k	-
3530	-	-	330R
3531	10k	10k	10k
3581	10k	10k	-
3595	-	-	-
3808	-	-	820R
4402	-	-	-
4404	-	-	-
6400	x	x	x
6403	x	x	x
6426	-	-	x
6440	-	x	-
6441	x	x	x
6447	x	x	x
6448	x	x	x
9402	-	-	x
9404	-	-	x
9405	-	-	x
9406	-	-	x
9407	-	-	-
9408	x	x	x
9409	-	-	-
9410	x	x	x
9411	-	-	-
9462	-	-	-
9488	x	x	x
9505	-	-	-
9508	-	-	x
9509	-	-	x

x - item in use

KEY-CDC PART - CIRCUIT DIAGRAM

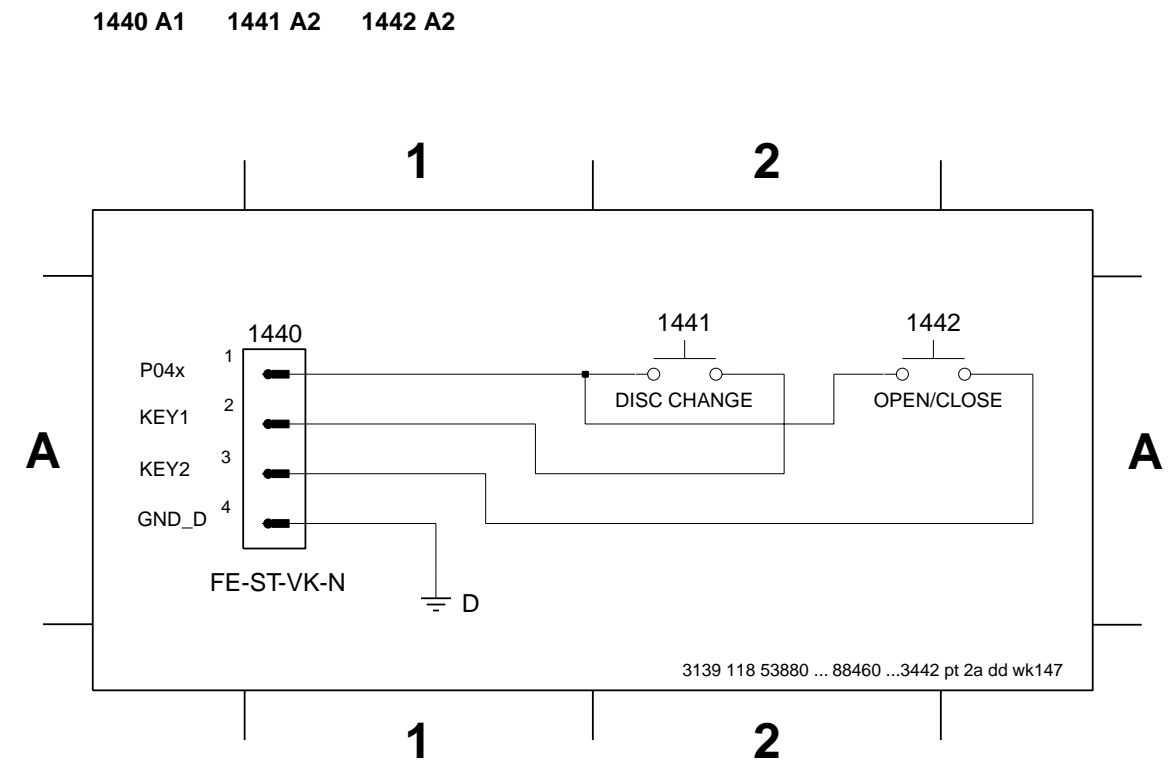

KEY-CDC PART - COMPONENT LAYOUT

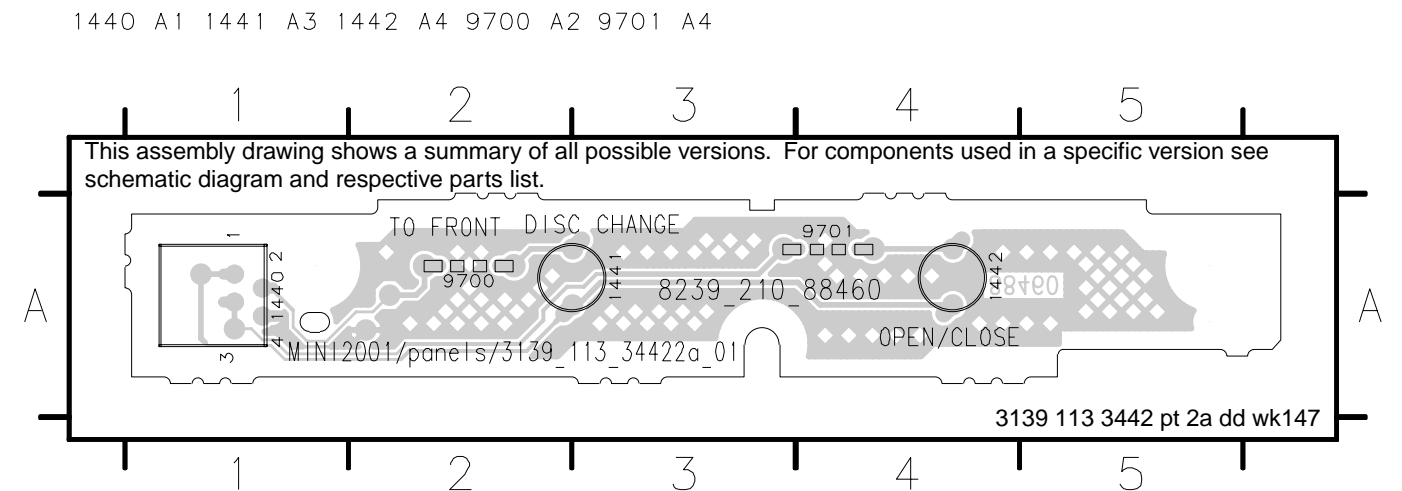

FRONT PART - CIRCUIT DIAGRAM

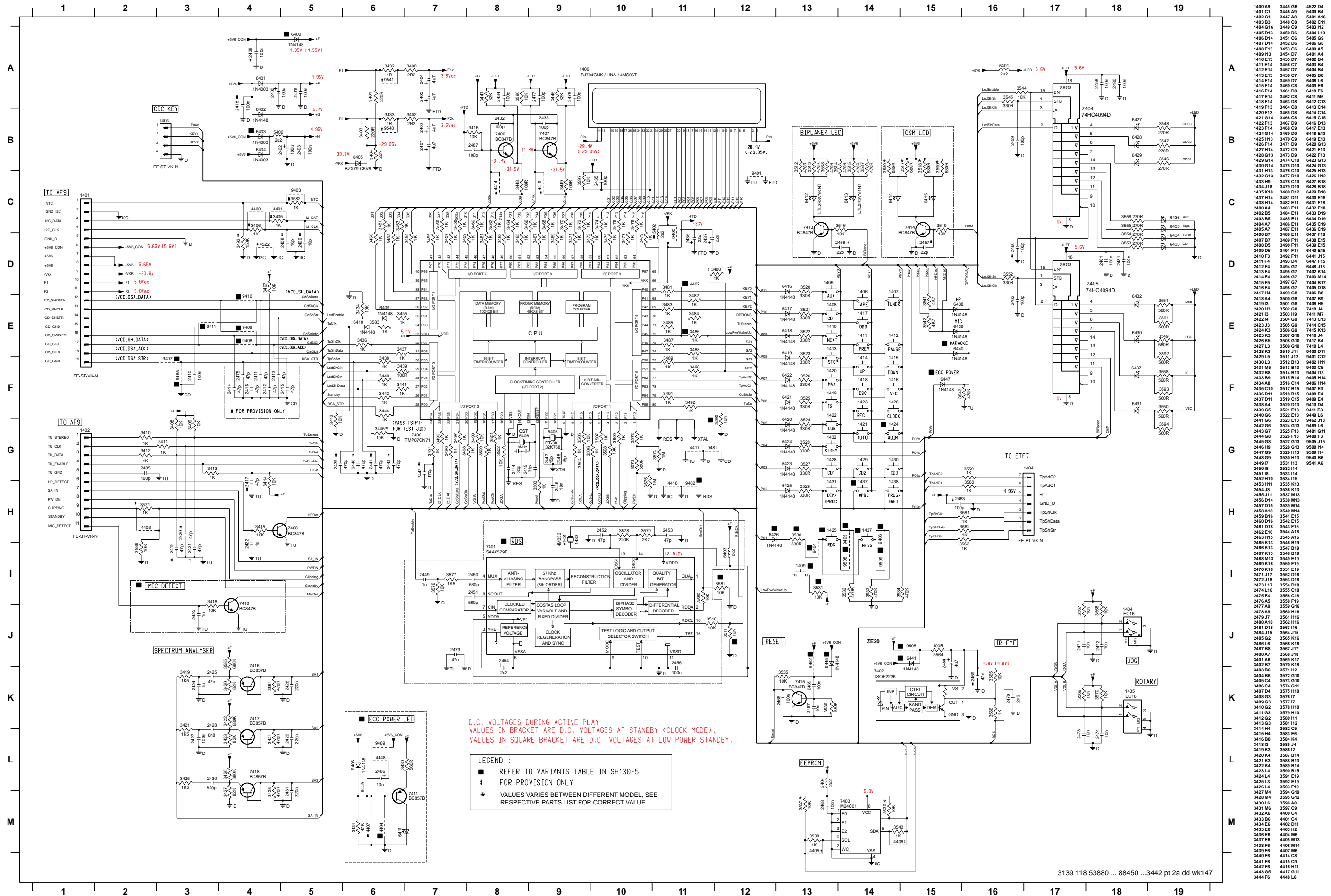

D.C. VOLTAGES DURING ACTIVE PLAY
 VALUES IN BRACKET ARE D.C. VOLTAGES AT STANDBY (CLOCK MODE).
 VALUES IN SQUARE BRACKET ARE D.C. VOLTAGES AT LOW POWER STANDBY.

LEGEND :
 ■ REFER TO VARIANTS TABLE IN SH130-5
 # FOR PROVISION ONLY
 * VALUES VARIES BETWEEN DIFFERENT MODEL, SEE RESPECTIVE PARTS LIST FOR CORRECT VALUE.

1400 A9	3445 G6	4522 D4
1401 C1	3446 A8	5400 B4
1402 G1	3447 A8	5401 A16
1403 B3	3448 C8	5402 C11
1404 G16	3449 C9	5403 I12
1405 D13	3450 D6	5404 L13
1406 D14	3451 C6	5405 G9
1407 D14	3452 D6	5406 G8
1408 E13	3453 C6	6400 A5
1409 H3	3454 D7	6401 A4
1410 E13	3455 D7	6402 B4
1411 E14	3456 C7	6403 B4
1412 E14	3457 D7	6404 B4
1413 E13	3458 C7	6405 B5
1414 F14	3459 D7	6406 L6
1415 F14	3460 C8	6409 E6
1416 F14	3461 D8	6410 E6
1417 E14	3462 C8	6411 M6
1418 F14	3463 D8	6412 C13
1419 F13	3464 C8	6413 C14
1420 F13	3465 D8	6414 C14
1421 G14	3466 C8	6415 C15
1422 F13	3467 D9	6416 D13
1423 F14	3468 C9	6417 E13
1424 G14	3469 D9	6418 F13
1425 H13	3470 C9	6419 E13
1426 F14	3471 D9	6420 G13
1427 H14	3472 C9	6421 F13
1428 G13	3473 D9	6422 F13
1429 G14	3474 C10	6423 G13
1430 G14	3475 D10	6424 G13
1431 H13	3476 C10	6425 H13
1432 G13	3477 D10	6426 H12
1433 H9	3478 C10	6427 B18
1434 H18	3479 D10	6428 B18
1435 K18	3480 D12	6429 B18
2400 A4	3483 E11	6432 E18
2401 B5	3484 E11	6433 D19
2403 B5	3485 E11	6434 D19
2404 A7	3486 E11	6435 C19
2405 A7	3487 E11	6436 C19
2406 B6	3488 E11	6437 F18
2407 B7	3489 F11	6438 E15
2408 D5	3490 F11	6439 E15
2409 D5	3491 F11	6440 E15
2410 F3	3492 F11	6441 J15
2411 F4	3493 D4	6442 F15
2412 F4	3494 G7	6443 J15
2413 F4	3495 G7	7400 M14
2414 F4	3496 G7	7400 M14
2415 F5	3497 G7	7400 B7
2416 F4	3498 G7	7400 B7
2417 H4	3499 G8	7406 B8
2418 A4	3500 H8	7407 D9
2419 D3	3501 H8	7408 H5
2420 H3	3502 H8	7410 J4
2421 D3	3503 H9	7411 M4
2422 H4	3504 G9	7415 C13
2423 J3	3505 G9	7414 C15
2424 K3	3506 G9	7415 C15
2425 K3	3507 G10	7416 K4
2426 K5	3508 G10	7417 K4
2427 L3	3509 G10	7418 L4
2428 K3	3510 H11	8400 D11
2429 L5	3511 J12	9401 C12
2430 L3	3512 B13	9402 H11
2431 M5	3513 B13	9403 C5
2432 B8	3514 B13	9404 H13
2433 B9	3515 B14	9405 H14
2434 A8	3516 C14	9406 H14
2435 C10	3517 B15	9407 E3
2436 D11	3518 B15	9408 E4
2437 D11	3519 C15	9409 E4
2438 A4	3520 D13	9410 D4
2439 O5	3521 E13	9411 E3
2440 O6	3522 E13	9412 E3
2441 O6	3523 E13	9462 J13
2442 O6	3524 G13	9469 L6
2443 O7	3525 F13	9471 H4
2444 O8	3526 F13	9488 F3
2445 O8	3527 G13	9505 J15
2446 O9	3528 G13	9506 G13
2447 O9	3529 H13	9509 H14
2448 O9	3530 H13	9540 B6
2449 I7	3531 H13	9541 A6
2450 I8	3532 H14	
2451 I8	3533 H14	
2452 I10	3534 H15	
2453 H11	3535 K13	
2454 J8	3536 K13	
2455 J11	3537 M13	
2456 D14	3538 M13	
2457 D15	3539 M14	
2458 A18	3540 E15	
2459 B16	3541 E15	
2460 D16	3542 E15	
2461 D18	3543 F15	
2462 E16	3544 A16	
2463 H15	3545 A16	
2464 H13	3546 E16	
2466 K13	3547 B19	
2467 K13	3548 B19	
2468 K13	3549 E19	
2469 K16	3550 F19	
2470 K16	3551 F19	
2471 J17	3552 D18	
2472 J18	3553 D18	
2473 J17	3554 D18	
2474 J18	3555 C18	
2475 F4	3556 C18	
2476 A5	3558 F19	
2477 A9	3559 G16	
2478 A9	3560 H16	
2479 J7	3561 H16	
2480 A18	3562 H16	
2481 D18	3563 H16	
2484 J15	3564 J15	
2485 O2	3566 K16	
2486 L4	3568 E16	
2487 B8	3567 J17	
3400 A7	3568 J17	
3401 A6	3569 K17	
3402 B7	3570 K18	
3404 B6	3572 G10	
3405 C4	3573 G10	
3406 C4	3574 G11	
3407 D4	3575 H10	
3408 G3	3576 I7	
3409 G3	3577 I7	
3410 G2	3578 H10	
3411 G3	3579 H10	
3412 O2	3580 H11	
3413 G3	3581 H12	
3414 H4	3582 C5	
3415 H4	3583 E5	
3416 B8	3584 K4	
3418 I3	3585 J4	
3419 K3	3586 J4	
3420 M4	3587 B14	
3421 K3	3588 B13	
3422 K4	3589 B14	
3423 L4	3590 B15	
3424 L4	3591 E19	
3425 L3	3592 E19	
3426 L4	3593 F19	
3427 M4	3594 G19	
3428 M4	3595 G12	
3430 L6	3596 A8	
3431 M6	3597 C9	
3432 A6	4400 C4	
3433 B6	4401 C4	
3434 E6	4402 D11	
3435 E6	4403 H2	
3436 E5	4404 M6	
3437 E6	4405 M13	
3438 F6	4406 M14	
3439 F6	4407 M6	
3440 F6	4414 C8	
3441 F6	4415 C9	
3442 F6	4416 H11	
3443 G5	4417 H11	
3444 F6	4418 L6	

HEADPHONE PART - CIRCUIT DIAGRAM

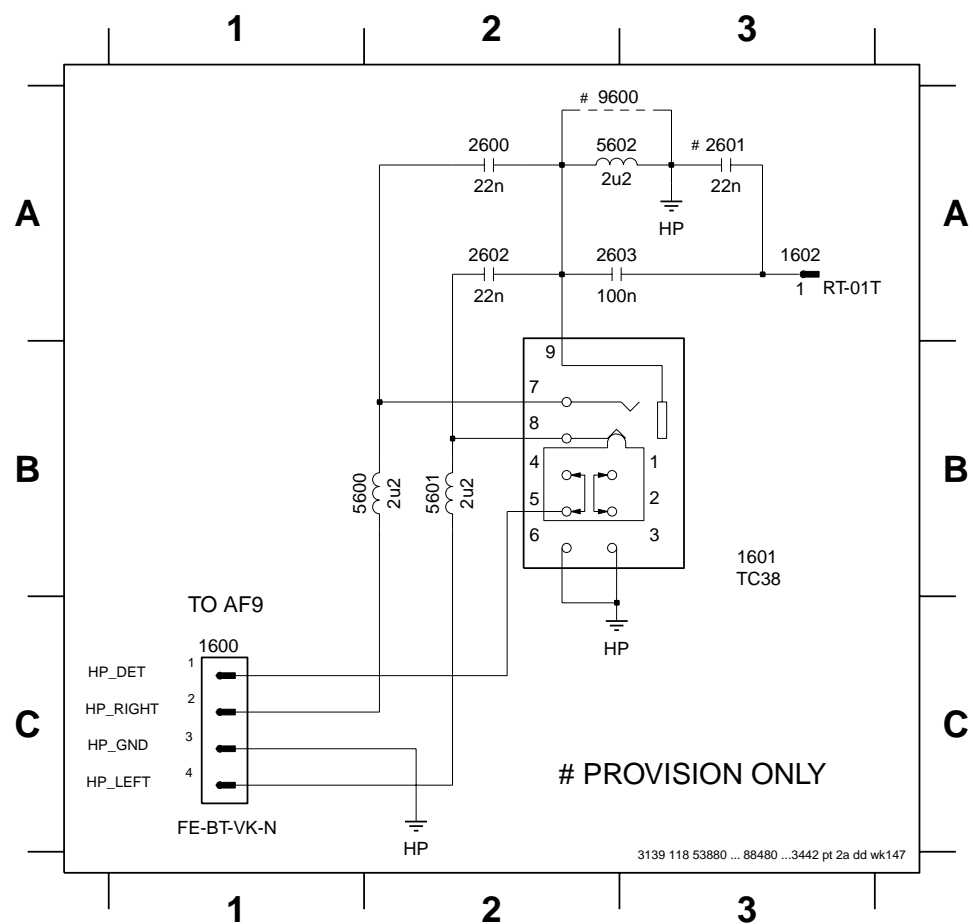

- 1600 C1
- 1601 B3
- 1602 A3
- 2600 A2
- 2601 A3
- 2602 A2
- 2603 A2
- 5600 B2
- 5601 B2
- 5602 A2
- 9600 A2

KARAOKE PART - COMPONENT & CHIP LAYOUTS

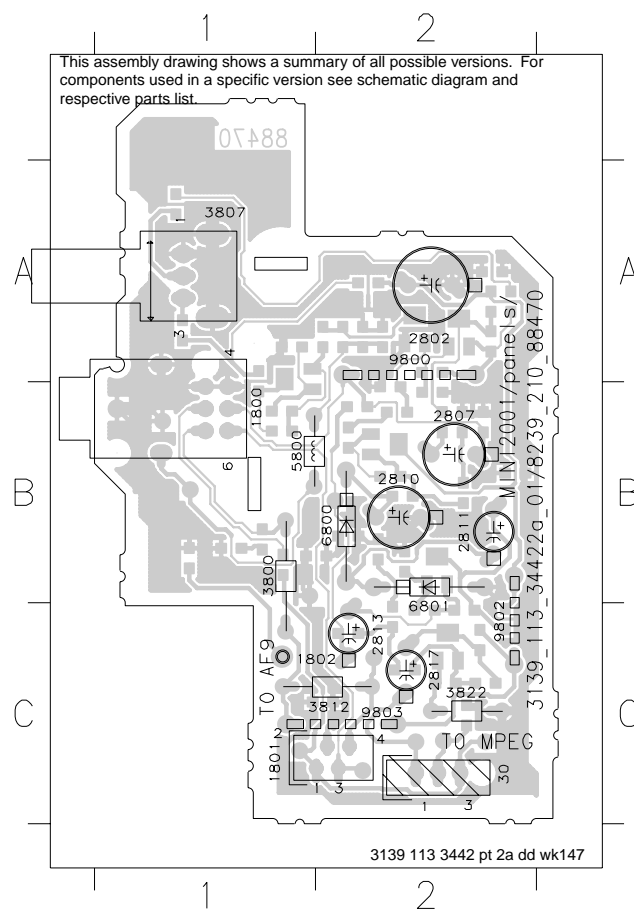

- 1600 C1
- 1601 B3
- 1602 A3
- 2600 A2
- 2601 A3
- 2602 A2
- 2603 A2
- 5600 B2
- 5601 B2
- 5602 A2
- 9600 A2

HEADPHONE PART - COMPONENT & CHIP LAYOUTS

- 1600 A2
- 1601 A1
- 1602 A2
- 5600 A2
- 5601 A2
- 5602 A2
- 9600 A2

- 2600 A2
- 2601 A1
- 2602 A2
- 2603 A2

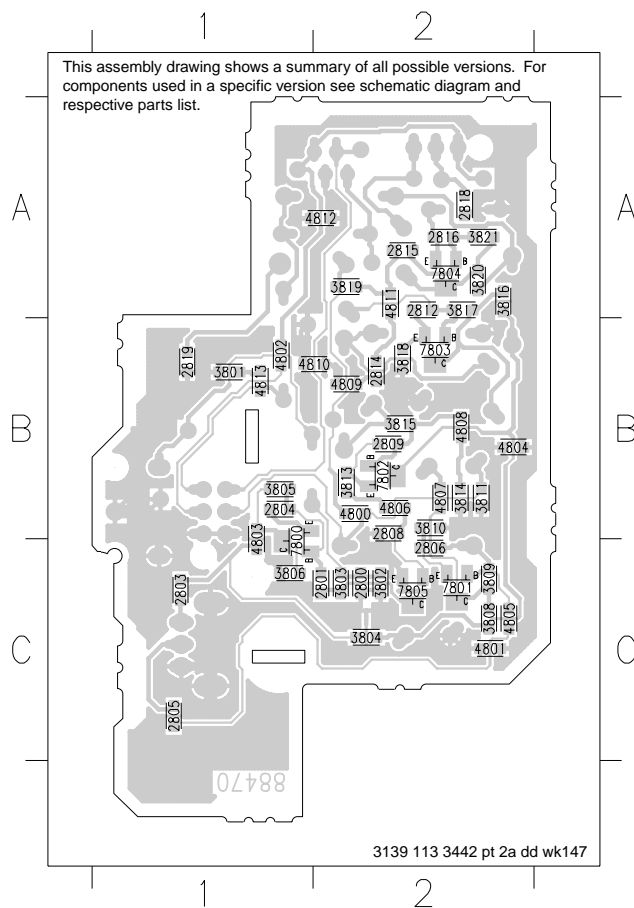
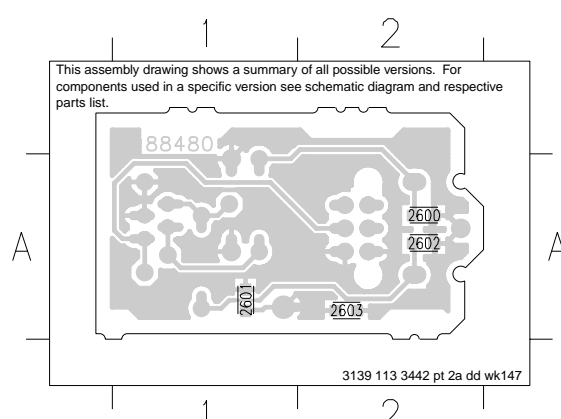
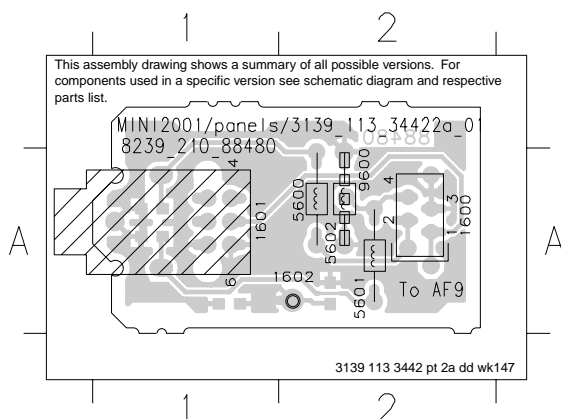

- 1600 C1
- 1601 B3
- 1602 A3
- 2600 A2
- 2601 A3
- 2602 A2
- 2603 A2
- 5600 B2
- 5601 B2
- 5602 A2
- 9600 A2

KARAOKE PART - CIRCUIT DIAGRAM

30 D9	1802 C2	2802 B5	2805 B5	2808 E3	2811 D6	2814 E7	2817 D8	3800 A2	3803 B3	3806 C4	3809 B6	3812 B8	3815 D5	3818 E6	3821 D8	5800 B2	7800 B4	7803 E6	9800 A5
1800 C1	2800 B2	2803 B4	2806 B6	2809 E4	2812 E6	2815 E7	2818 E8	3801 A2	3804 B4	3807 B4	3810 C6	3813 D4	3816 D6	3819 E7	3822 E8	6800 D5	7801 B6	7804 E8	
1801 B9	2801 B3	2804 B4	2807 B6	2810 E5	2813 E6	2816 E8	2819 C3	3802 B2	3805 B4	3808 B6	3811 B6	3814 E5	3817 D6	3820 D8	4800 D7	6801 E5	7802 D4	7805 D3	

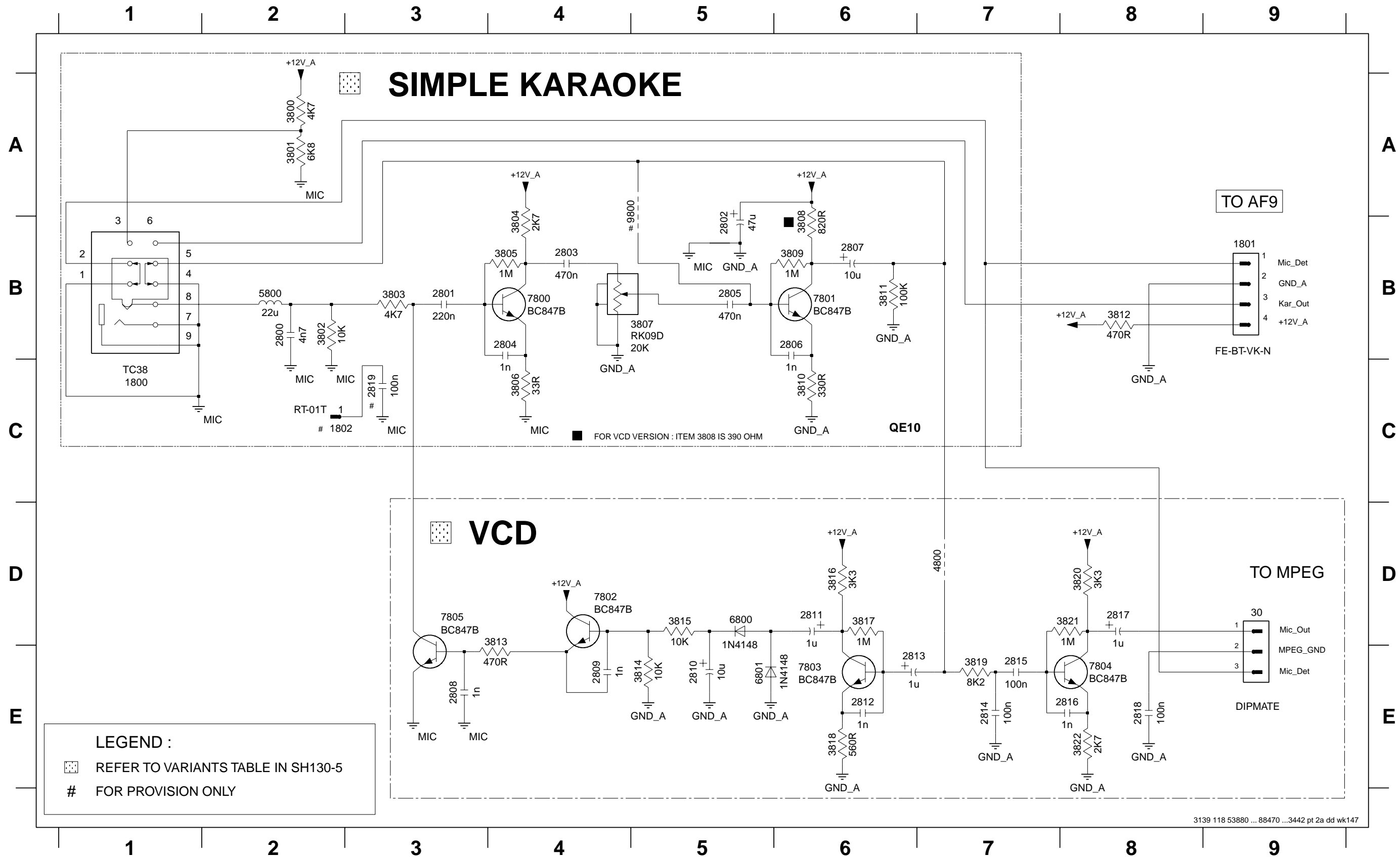

ELECTRICAL PARTS LIST - FRONT BOARD**MISCELLANEOUS**

1400	3139 110 52900	FTD Display HNA-14MS06T	2410	4822 126 14305	100nF 10% 16V
1401	4822 265 11545	Flex Socket 19 Pin Hort.	2422	3198 017 41050	1μF 10V
1402	2422 025 14541	Flex Socket 11 Pin Hort.	2423	3198 017 41050	1μF 10V
1403	4822 265 11183	Flex Socket 4 Pin Hort.	2424	3198 017 41050	1μF 10V
1404	4822 267 10953	Flex Socket 7 Pin Vert.	2425	3198 017 34730	47nF 16V
1405	4822 276 13775	Tact Switch	2426	4822 126 13879	220nF +80/-20% 16V
1406	4822 276 13775	Tact Switch	2427	4822 126 14305	100nF 10% 16V
1407	4822 276 13775	Tact Switch	2428	5322 126 11582	6,8nF 10% 63V
1408	4822 276 13775	Tact Switch	2429	4822 126 13879	220nF +80/-20% 16V
1409	4822 276 13775	Tact Switch	2430	3198 016 38210	820pF 25V
1410	4822 276 13775	Tact Switch	2431	4822 126 13879	220nF +80/-20% 16V
1411	4822 276 13775	Tact Switch	2432	4822 122 31765	100pF 2% 63V
1412	4822 276 13775	Tact Switch	2433	4822 122 31765	100pF 2% 63V
1413	4822 276 13775	Tact Switch	2434	4822 122 31765	100pF 2% 63V
1414	4822 276 13775	Tact Switch	2435	4822 122 31765	100pF 2% 63V
1415	4822 276 13775	Tact Switch	2436	3198 028 52290	22μF 20% 50V
1416	4822 276 13775	Tact Switch	2437	3198 028 52290	22μF 20% 50V
1417	4822 276 13775	Tact Switch	2444	2222 867 15339	33pF 5% 50V
1418	4822 276 13775	Tact Switch	2445	2222 867 15339	33pF 5% 50V
1419	4822 276 13775	Tact Switch	2446	5322 126 11583	10nF 10% 50V
1420	4822 276 13775	Tact Switch	2447	4822 122 33752	15pF 5% 50V
1421	4822 276 13775	Tact Switch	2448	4822 122 33752	15pF 5% 50V
1422	4822 276 13775	Tact Switch	2449	4822 122 33197	1nF 10% 50V
1423	4822 276 13775	Tact Switch	2450	4822 126 14249	560pF 10% 50V
1425	4822 276 13775	Tact Switch	2451	4822 126 14249	560pF 10% 50V
1426	4822 276 13775	Tact Switch	2452	4822 122 33777	47pF 5% 63V
1427	4822 276 13775	Tact Switch	2453	4822 122 33777	47pF 5% 63V
1428	4822 276 13775	Tact Switch	2454	4822 124 22652	2,2μF 20% 50V
1429	4822 276 13775	Tact Switch	2455	4822 126 14305	100nF 10% 16V
1430	4822 276 13775	Tact Switch	2458	4822 126 14305	100nF 10% 16V
1431	4822 276 13775	Tact Switch	2459	4822 122 31765	100pF 2% 63V
1432	4822 276 13775	Tact Switch	2461	4822 126 14305	100nF 10% 16V
1433	4822 242 11033	X'tal Resonator 4,332MHz	2462	4822 122 31765	100pF 2% 63V
1434	2422 129 16385	Rotary Encoder 12P	2465	4822 126 14305	100nF 10% 16V
1435	4822 273 10365	Rotary Encoder 24P	2466	4822 126 14305	100nF 10% 16V
1438	4822 276 13775	Tact Switch	2467	5322 126 11583	10nF 10% 50V
1440	4822 265 11183	Flex Socket 4 Pin Hort.	2468	4822 126 14305	100nF 10% 16V
1441	4822 276 13775	Tact Switch	2470	4822 126 14238	2,2nF 50V
1442	4822 276 13775	Tact Switch	2471	5322 126 11583	10nF 10% 50V
1600	4822 267 10733	Flex Socket 4 Pin Vert.	2472	5322 126 11583	10nF 10% 50V
1601	4822 265 11529	Headphone Socket	2473	5322 126 11583	10nF 10% 50V
1800	4822 265 11529	Karaoke Mic Socket	2474	5322 126 11583	10nF 10% 50V
1801	4822 267 10733	Flex Socket 4 Pin Vert.	2476	4822 126 14305	100nF 10% 16V

CAPACITORS

2400	4822 124 23432	100μF 20% 10V	2477	4822 122 31765	100pF 2% 63V
2402	4822 124 23432	100μF 20% 10V	2478	4822 122 31765	100pF 2% 63V
2403	4822 126 14305	100nF 10% 16V	2479	4822 126 12785	47nF 50V
2404	4822 124 12032	4,7μF 20% 50V	2480	4822 126 14305	100nF 10% 16V
2405	4822 124 12032	4,7μF 20% 50V	2481	4822 126 14305	100nF 10% 16V
2406	4822 124 12032	4,7μF 20% 50V	2484	4822 124 40769	4,7μF 20% 100V
2407	4822 124 12032	4,7μF 20% 50V	2485	4822 122 31765	100pF 2% 63V
			2486	4822 124 40248	10μF 20% 63V
			2487	4822 122 31765	100pF 2% 63V

ELECTRICAL PARTS LIST - FRONT BOARD

2600	4822 126 14494	22nF 10% 25V	3443	4822 051 30103	10k 5% 0,062W
2602	4822 126 14494	22nF 10% 25V	3444	4822 051 30102	1k 5% 0,062W
2603	4822 126 14305	100nF 10% 16V	3446	4822 117 12864	82k 5% 0,6W
2800	4822 126 13193	4,7nF 10% 63V	3447	4822 116 52304	82k 5% 0,5W
2801	4822 126 13879	220nF +80/-20% 16V	3448	4822 051 30101	100R 5% 0,062W
2802	3198 028 44790	47μF 20% 35V	3449	4822 051 30101	100R 5% 0,062W
2803	4822 126 13482	470nF 80/20% 16V	3450	4822 051 30102	1k 5% 0,062W
2804	5322 126 11578	1nF 10% 50V	3451	4822 051 30102	1k 5% 0,062W
2805	4822 126 13482	470nF 80/20% 16V	3452	4822 051 30102	1k 5% 0,062W
2806	5322 126 11578	1nF 10% 50V	3453	4822 051 30102	1k 5% 0,062W
2807	4822 124 12255	10μF 20% 50V	3454	4822 051 30102	1k 5% 0,062W

RESISTORS

3400	4822 116 81154	2R2 5% 0,5W	3456	4822 051 30102	1k 5% 0,062W
3401	4822 116 83872	220R 5% 0,5W	3457	4822 051 30102	1k 5% 0,062W
3402	4822 116 81154	2R2 5% 0,5W	3458	4822 051 30102	1k 5% 0,062W
3403	4822 116 83872	220R 5% 0,5W	3459	4822 051 30102	1k 5% 0,062W
3404	4822 116 52257	22k 5% 0,5W	3460	4822 051 30102	1k 5% 0,062W
3407	4822 050 21003	10k 1% 0,6W	3461	4822 051 30102	1k 5% 0,062W
3408	4822 050 21003	10k 1% 0,6W	3462	4822 051 30102	1k 5% 0,062W
3409	4822 051 30103	10k 5% 0,062W	3463	4822 051 30102	1k 5% 0,062W
3410	4822 050 11002	1k 1% 0,4W	3464	4822 051 30102	1k 5% 0,062W
3411	4822 051 30102	1k 5% 0,062W	3465	4822 051 30102	1k 5% 0,062W
3412	4822 051 30102	1k 5% 0,062W	3466	4822 051 30102	1k 5% 0,062W
3413	4822 051 30102	1k 5% 0,062W	3467	4822 051 30102	1k 5% 0,062W
3414	4822 051 30103	10k 5% 0,062W	3468	4822 051 30102	1k 5% 0,062W
3415	4822 051 30103	10k 5% 0,062W	3469	4822 051 30102	1k 5% 0,062W
3416	4822 051 30103	10k 5% 0,062W	3470	4822 051 30102	1k 5% 0,062W
3418	4822 051 30103	10k 5% 0,062W	3471	4822 051 30102	1k 5% 0,062W
3419	4822 116 52243	1k5 5% 0,5W	3472	4822 051 30102	1k 5% 0,062W
3420	4822 117 12864	82k 5% 0,6W	3473	4822 051 30102	1k 5% 0,062W
3421	4822 116 52243	1k5 5% 0,5W	3474	4822 051 30102	1k 5% 0,062W
3422	4822 051 30684	680k 5% 0,062W	3475	4822 051 30102	1k 5% 0,062W
3423	4822 117 12864	82k 5% 0,6W	3476	4822 051 30102	1k 5% 0,062W
3424	4822 051 30474	470k 5% 0,062W	3477	4822 051 30102	1k 5% 0,062W
3425	4822 116 52243	1k5 5% 0,5W	3478	4822 051 30102	1k 5% 0,062W
3426	4822 051 30684	680k 5% 0,062W	3479	4822 051 30102	1k 5% 0,062W
3427	4822 117 12864	82k 5% 0,6W	3481	4822 050 11002	1k 1% 0,4W
3428	4822 051 30474	470k 5% 0,062W	3482	4822 050 11002	1k 1% 0,4W
3430	4822 051 30561	560R 5% 0,062W	3483	4822 050 11002	1k 1% 0,4W
3431	4822 117 12925	47k 1% 0,063W	3484	4822 051 30102	1k 5% 0,062W
3432	4822 116 80176	1R 5% 0,5W	3485	4822 051 30102	1k 5% 0,062W
3433	4822 116 80176	1R 5% 0,5W	3486	4822 051 30102	1k 5% 0,062W
3434	4822 051 30103	10k 5% 0,062W	3487	4822 051 30102	1k 5% 0,062W
3435	4822 051 30102	1k 5% 0,062W	3488	4822 051 30102	1k 5% 0,062W
3436	4822 051 30102	1k 5% 0,062W	3489	4822 051 30102	1k 5% 0,062W
3437	4822 051 30102	1k 5% 0,062W	3490	4822 051 30102	1k 5% 0,062W
3438	4822 051 30102	1k 5% 0,062W	3491	4822 051 30102	1k 5% 0,062W
3439	4822 051 30101	100R 5% 0,062W	3492	4822 051 30102	1k 5% 0,062W
3440	4822 051 30102	1k 5% 0,062W	3494	4822 051 30102	1k 5% 0,062W
3441	4822 051 30102	1k 5% 0,062W	3495	4822 051 30102	1k 5% 0,062W
3442	4822 051 30102	1k 5% 0,062W	3496	4822 051 30102	1k 5% 0,062W
			3497	4822 051 30102	1k 5% 0,062W

ELECTRICAL PARTS LIST - FRONT BOARD

RESISTORS

3498	4822 051 30102	1k 5% 0,062W	3550	4822 051 30561	560R 5% 0,062W
3499	4822 050 21003	10k 1% 0,6W	3551	4822 051 30561	560R 5% 0,062W
3500	4822 051 30102	1k 5% 0,062W	3552	4822 051 30331	330R 5% 0,062W
3501	4822 051 30102	1k 5% 0,062W	3553	4822 116 83876	270R 5% 0,5W
3502	4822 050 21003	10k 1% 0,6W	3554	4822 116 83876	270R 5% 0,5W
3503	4822 050 11002	1k 1% 0,4W	3555	4822 116 83876	270R 5% 0,5W
3504	4822 051 30102	1k 5% 0,062W	3556	4822 116 83876	270R 5% 0,5W
3505	4822 050 21003	10k 1% 0,6W	3558	4822 051 30561	560R 5% 0,062W
3506	4822 051 30102	1k 5% 0,062W	3559	4822 051 30102	1k 5% 0,062W
3507	4822 051 30102	1k 5% 0,062W	3560	4822 051 30102	1k 5% 0,062W
3508	4822 051 30103	10k 5% 0,062W	3561	4822 050 11002	1k 1% 0,4W
3509	4822 050 11002	1k 1% 0,4W	3562	4822 051 30102	1k 5% 0,062W
3510	4822 050 21003	10k 1% 0,6W	3563	4822 050 11002	1k 1% 0,4W
3511	4822 051 30103	10k 5% 0,062W	3564	4822 051 30101	100R 5% 0,062W
3512	4822 051 30471	470R 5% 0,062W	3565	4822 051 30103	10k 5% 0,062W
3513	4822 051 30471	470R 5% 0,062W	3566	4822 050 11002	1k 1% 0,4W
3514	4822 051 30471	470R 5% 0,062W	3567	4822 051 30103	10k 5% 0,062W
3515	4822 051 30471	470R 5% 0,062W	3568	4822 051 30103	10k 5% 0,062W
3516	4822 051 30103	10k 5% 0,062W	3569	4822 051 30103	10k 5% 0,062W
3517	4822 117 11817	1k2 1% 1/16W	3570	4822 051 30103	10k 5% 0,062W
3518	4822 117 11817	1k2 1% 1/16W	3572	4822 051 30102	1k 5% 0,062W
3519	4822 051 30103	10k 5% 0,062W	3573	4822 051 30684	680k 5% 0,062W
3520	4822 051 30331	330R 5% 0,062W	3574	4822 051 30105	1M 5% 0,062W
3521	4822 051 30331	330R 5% 0,062W	3575	4822 051 30105	1M 5% 0,062W
3522	4822 051 30331	330R 5% 0,062W	3576	4822 051 30103	10k 5% 0,062W
3523	4822 051 30331	330R 5% 0,062W	3577	4822 051 30152	1k5 5% 0,062W
3524	4822 051 30331	330R 5% 0,062W	3578	4822 117 12891	220k 1% 0,062W
3525	4822 051 30331	330R 5% 0,062W	3579	4822 051 30222	2k2 5% 0,062W
3526	4822 051 30331	330R 5% 0,062W	3580	4822 050 21003	10k 1% 0,6W
3527	4822 051 30331	330R 5% 0,062W	3581	4822 051 30103	10k 5% 0,062W
3528	4822 051 30331	330R 5% 0,062W	3583	4822 051 30102	1k 5% 0,062W
3529	4822 116 52219	330R 5% 0,5W	3584	4822 051 30474	470k 5% 0,062W
3530	4822 051 30331	330R 5% 0,062W	3585	4822 051 30684	680k 5% 0,062W
3531	4822 051 30103	10k 5% 0,062W	3586	4822 051 30103	10k 5% 0,062W
3532	4822 051 30474	470k 5% 0,062W	3587	4822 051 30471	470R 5% 0,062W
3533	4822 051 30474	470k 5% 0,062W	3588	4822 051 30471	470R 5% 0,062W
3534	4822 051 30474	470k 5% 0,062W	3589	4822 117 11817	1k2 1% 1/16W
3535	4822 051 30103	10k 5% 0,062W	3590	4822 117 11817	1k2 1% 1/16W
3536	4822 117 13632	100k 1% 0603 0,62W	3591	4822 051 30561	560R 5% 0,062W
3537	4822 051 30682	6k8 5% 0,062W	3592	4822 051 30561	560R 5% 0,062W
3538	4822 051 30102	1k 5% 0,062W	3593	4822 051 30561	560R 5% 0,062W
3539	4822 051 30682	6k8 5% 0,062W	3594	4822 051 30561	560R 5% 0,062W
3540	4822 051 30102	1k 5% 0,062W	3596	4822 051 30103	10k 5% 0,062W
3541	4822 051 30472	4k7 5% 0,062W	3597	4822 051 30103	10k 5% 0,062W
3542	4822 051 30472	4k7 5% 0,062W	3800	4822 116 52283	4k7 5% 0,5W
3543	4822 051 30474	470k 5% 0,062W	3801	4822 051 30682	6k8 5% 0,062W
3544	4822 050 21003	10k 1% 0,6W	3802	4822 051 30103	10k 5% 0,062W
3545	4822 051 30331	330R 5% 0,062W	3803	4822 051 30472	4k7 5% 0,062W
3546	4822 051 30271	270R 5% 0,062W	3804	4822 051 30272	2k7 5% 0,062W
3547	4822 051 30271	270R 5% 0,062W	3805	4822 051 30105	1M 5% 0,062W
3548	4822 051 30271	270R 5% 0,062W	3806	4822 051 30339	33R 5% 0,062W
3549	4822 051 30561	560R 5% 0,062W	3807	2120 366 90291	Potm Rotary 20K

ELECTRICAL PARTS LIST - FRONT BOARD

3808	4822 117 12968	820R 5% 0,62W	4462	4822 051 30008	OR Jumper 0603
3809	4822 051 30105	1M 5% 0,062W	4463	4822 051 30008	OR Jumper 0603
3810	4822 051 30331	330R 5% 0,062W	4464	4822 051 30008	OR Jumper 0603
3811	4822 117 13632	100k 1% 0,062W	4465	4822 051 30008	OR Jumper 0603
3812	4822 116 83883	470R 5% 0,5W	4466	4822 051 30008	OR Jumper 0603
4400	4822 051 30008	OR Jumper 0603	4467	4822 051 30008	OR Jumper 0603
4401	4822 051 30008	OR Jumper 0603	4468	4822 051 30008	OR Jumper 0603
4403	4822 051 30008	OR Jumper 0603	4469	4822 051 30008	OR Jumper 0603
4416	4822 051 30008	OR Jumper 0603	4470	4822 051 30008	OR Jumper 0603
4417	4822 051 30008	OR Jumper 0603	4471	4822 051 30008	OR Jumper 0603
4420	4822 051 30008	OR Jumper 0603	4472	4822 051 30008	OR Jumper 0603
4421	4822 051 30008	OR Jumper 0603	4473	4822 051 30008	OR Jumper 0603
4422	4822 051 30008	OR Jumper 0603	4474	4822 051 30008	OR Jumper 0603
4423	4822 051 30008	OR Jumper 0603	4475	4822 051 30008	OR Jumper 0603
4424	4822 051 30008	OR Jumper 0603	4476	4822 051 30008	OR Jumper 0603
4425	4822 051 30008	OR Jumper 0603	4477	4822 051 30008	OR Jumper 0603
4426	4822 051 30008	OR Jumper 0603	4478	4822 051 30008	OR Jumper 0603
4427	4822 051 30008	OR Jumper 0603	4479	4822 051 30008	OR Jumper 0603
4428	4822 051 30008	OR Jumper 0603	4480	4822 051 30008	OR Jumper 0603
4429	4822 051 30008	OR Jumper 0603	4481	4822 051 30008	OR Jumper 0603
4430	4822 051 30008	OR Jumper 0603	4482	4822 051 30008	OR Jumper 0603
4431	4822 051 30008	OR Jumper 0603	4483	4822 051 30008	OR Jumper 0603
4432	4822 051 30008	OR Jumper 0603	4484	4822 051 30008	OR Jumper 0603
4433	4822 051 30008	OR Jumper 0603	4485	4822 051 30008	OR Jumper 0603
4434	4822 051 30008	OR Jumper 0603	4486	4822 051 30008	OR Jumper 0603
4435	4822 051 30008	OR Jumper 0603	4487	4822 051 30008	OR Jumper 0603
4436	4822 051 30008	OR Jumper 0603	4488	4822 051 30008	OR Jumper 0603
4437	4822 051 30008	OR Jumper 0603	4489	4822 051 30008	OR Jumper 0603
4438	4822 051 30008	OR Jumper 0603	4490	4822 051 30008	OR Jumper 0603
4439	4822 051 30008	OR Jumper 0603	4492	4822 051 30008	OR Jumper 0603
4440	4822 051 30008	OR Jumper 0603	4494	4822 051 30008	OR Jumper 0603
4441	4822 051 30008	OR Jumper 0603	4495	4822 051 30008	OR Jumper 0603
4442	4822 051 30008	OR Jumper 0603	4496	4822 051 30008	OR Jumper 0603
4443	4822 051 30008	OR Jumper 0603	4498	4822 051 30008	OR Jumper 0603
4444	4822 051 30008	OR Jumper 0603	4499	4822 051 30008	OR Jumper 0603
4445	4822 051 30008	OR Jumper 0603	4500	4822 051 30008	OR Jumper 0603
4446	4822 051 30008	OR Jumper 0603	4502	4822 051 30008	OR Jumper 0603
4447	4822 051 30008	OR Jumper 0603	4503	4822 051 30008	OR Jumper 0603
4448	4822 051 30008	OR Jumper 0603	4504	4822 051 30008	OR Jumper 0603
4449	4822 051 30008	OR Jumper 0603	4505	4822 051 30008	OR Jumper 0603
4450	4822 051 30008	OR Jumper 0603	4506	4822 051 30008	OR Jumper 0603
4451	4822 051 30008	OR Jumper 0603	4507	4822 051 30008	OR Jumper 0603
4452	4822 051 30008	OR Jumper 0603	4508	4822 051 30008	OR Jumper 0603
4453	4822 051 30008	OR Jumper 0603	4509	4822 051 30008	OR Jumper 0603
4454	4822 051 30008	OR Jumper 0603	4510	4822 051 30008	OR Jumper 0603
4455	4822 051 30008	OR Jumper 0603	4511	4822 051 30008	OR Jumper 0603
4456	4822 051 30008	OR Jumper 0603	4512	4822 051 30008	OR Jumper 0603
4457	4822 051 30008	OR Jumper 0603	4513	4822 051 30008	OR Jumper 0603
4458	4822 051 30008	OR Jumper 0603	4514	4822 051 30008	OR Jumper 0603
4459	4822 051 30008	OR Jumper 0603	4515	4822 051 30008	OR Jumper 0603
4460	4822 051 30008	OR Jumper 0603	4516	4822 051 30008	OR Jumper 0603
4461	4822 051 30008	OR Jumper 0603	4517	4822 051 30008	OR Jumper 0603

ELECTRICAL PARTS LIST - FRONT BOARD**RESISTORS**

4518	4822 051 30008	OR Jumper 0603
4519	4822 051 30008	OR Jumper 0603
4520	4822 051 30008	OR Jumper 0603
4521	4822 051 30008	OR Jumper 0603
4523	4822 051 30008	OR Jumper 0603
4524	4822 051 30008	OR Jumper 0603
4525	4822 051 30008	OR Jumper 0603
4526	4822 051 30008	OR Jumper 0603
4527	4822 051 30008	OR Jumper 0603
4528	4822 051 30008	OR Jumper 0603
4529	4822 051 30008	OR Jumper 0603
4530	4822 051 30008	OR Jumper 0603
4531	4822 051 30008	OR Jumper 0603
4532	4822 051 30008	OR Jumper 0603
4533	4822 051 30008	OR Jumper 0603
4534	4822 051 30008	OR Jumper 0603
4535	4822 051 30008	OR Jumper 0603
4536	4822 051 30008	OR Jumper 0603
4537	4822 051 30008	OR Jumper 0603
4538	4822 051 30008	OR Jumper 0603
4539	4822 051 30008	OR Jumper 0603
4540	4822 051 30008	OR Jumper 0603
4541	4822 051 30008	OR Jumper 0603
4542	4822 051 30008	OR Jumper 0603
4801	4822 051 30008	OR Jumper 0603
4802	4822 051 30008	OR Jumper 0603
4803	4822 051 30008	OR Jumper 0603
4804	4822 051 30008	OR Jumper 0603
4805	4822 051 30008	OR Jumper 0603
4806	4822 051 30008	OR Jumper 0603
4807	4822 051 30008	OR Jumper 0603
4808	4822 051 30008	OR Jumper 0603
4809	4822 051 30008	OR Jumper 0603
4810	4822 051 30008	OR Jumper 0603
4811	4822 051 30008	OR Jumper 0603
4812	4822 051 30008	OR Jumper 0603
4813	4822 051 30008	OR Jumper 0603

COILS & FILTERS

5400	4822 157 62552	Coil 2,2μH 5%
5401	4822 157 62552	Coil 2,2μH 5%
5403	4822 157 62552	Coil 2,2μH 5%
5404	4822 157 62552	Coil 2,2μH 5%
5405	2422 543 01069	X'tal Resonator 32,768kHz
5406	4822 242 72066	Ceram Resonator 8MHz
5600	4822 157 62552	Coil 2,2μH 5%
5601	4822 157 62552	Coil 2,2μH 5%
5602	4822 157 62552	Coil 2,2μH 5%
5800	4822 157 11235	Coil 22μH 5%

DIODES

6400	4822 130 30621	1N4148
------	----------------	--------

6401	4822 130 31878	1N4003G
6402	4822 130 30621	1N4148
6403	4822 130 31878	1N4003G
6404	4822 130 31878	1N4003G
6405	4822 130 34173	BZX79-B5V6
6406	4822 130 30621	1N4148
6409	4822 130 30621	1N4148
6410	4822 130 30621	1N4148
6411	9322 167 73676	LTL-4221NLC-KA
6412	9322 161 99676	LTL-2R3VYKNT
6413	9322 161 99676	LTL-2R3VYKNT
6414	9322 172 75676	LTL-1CHKFK
6415	9322 172 75676	LTL-1CHKFK
6416	4822 130 30621	1N4148
6417	4822 130 30621	1N4148
6418	4822 130 30621	1N4148
6419	4822 130 30621	1N4148
6420	4822 130 30621	1N4148
6421	4822 130 30621	1N4148
6422	4822 130 30621	1N4148
6423	4822 130 30621	1N4148
6424	4822 130 30621	1N4148
6425	4822 130 30621	1N4148
6426	4822 130 30621	1N4148
6427	4822 130 11589	LTL-1CHAE
6428	4822 130 11589	LTL-1CHAE
6429	4822 130 11589	LTL-1CHAE
6430	4822 130 11589	LTL-1CHAE
6431	4822 130 11589	LTL-1CHAE
6432	4822 130 11589	LTL-1CHAE
6433	4822 130 10791	LTL-1CHGE
6434	4822 130 10791	LTL-1CHGE
6435	4822 130 10791	LTL-1CHGE
6436	4822 130 10791	LTL-1CHGE
6437	4822 130 10791	LTL-1CHGE
6438	4822 130 30621	1N4148
6439	4822 130 30621	1N4148
6440	4822 130 30621	1N4148
6441	4822 130 30621	1N4148
6448	4822 130 30621	1N4148

TRANSISTORS & INTEGRATED CIRCUITS

7401	9352 679 67118	SAA6579T/V1/M4
7400	3140 110 52151	TMP87CS71BF
7402	9322 155 82667	IR Receiver TSOP2236ZC1
7403	9965 000 04931	M24C01-WMN6
7404	4822 209 15449	74HC4094D
7405	4822 209 15449	74HC4094D
7406	5322 130 60159	BC846B
7407	5322 130 60159	BC846B
7408	5322 130 60159	BC846B

ELECTRICAL PARTS LIST - FRONT BOARD

7410	4822 130 60511	BC847B
7411	4822 130 60373	BC856B
7413	5322 130 60159	BC846B
7414	5322 130 60159	BC846B
7415	5322 130 60159	BC846B
7416	4822 130 60373	BC856B
7417	4822 130 60373	BC857B
7418	4822 130 60373	BC857B
7800	4822 130 60511	BC847B
7801	4822 130 60511	BC847B

Note: Only the parts mentioned in this list are normal service spare parts.

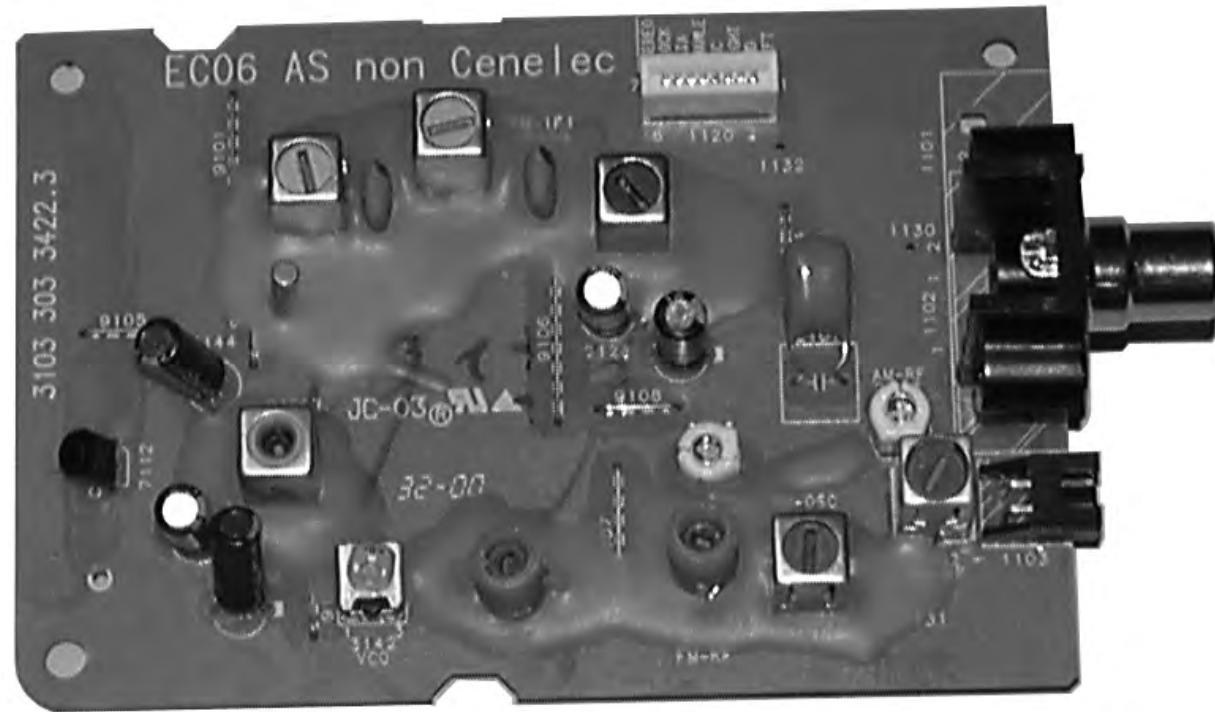

BLOCK DIAGRAM

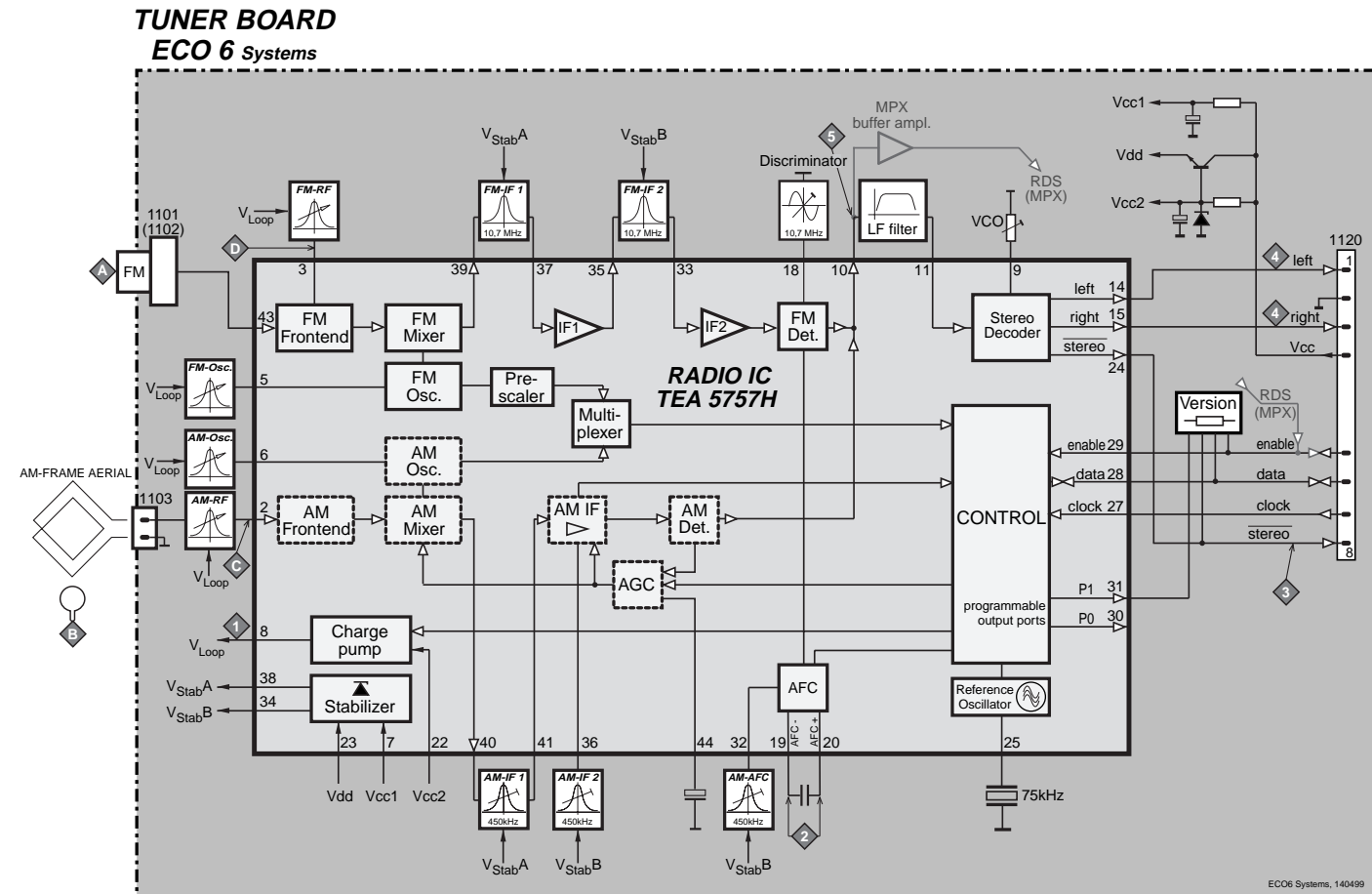

ECO6 Tuner Board
version: *SYSTEMS non-CENELEC*

TABLE OF CONTENTS

Blockdiagram7A-1
 Schematic Diagram7A-2
 Component Layout.....7A-3
 Adjustment table7A-3
 Electrical Partslist.....7A-4

TUNER BOARD ECO6 / SYSTEMS NON CENELEC

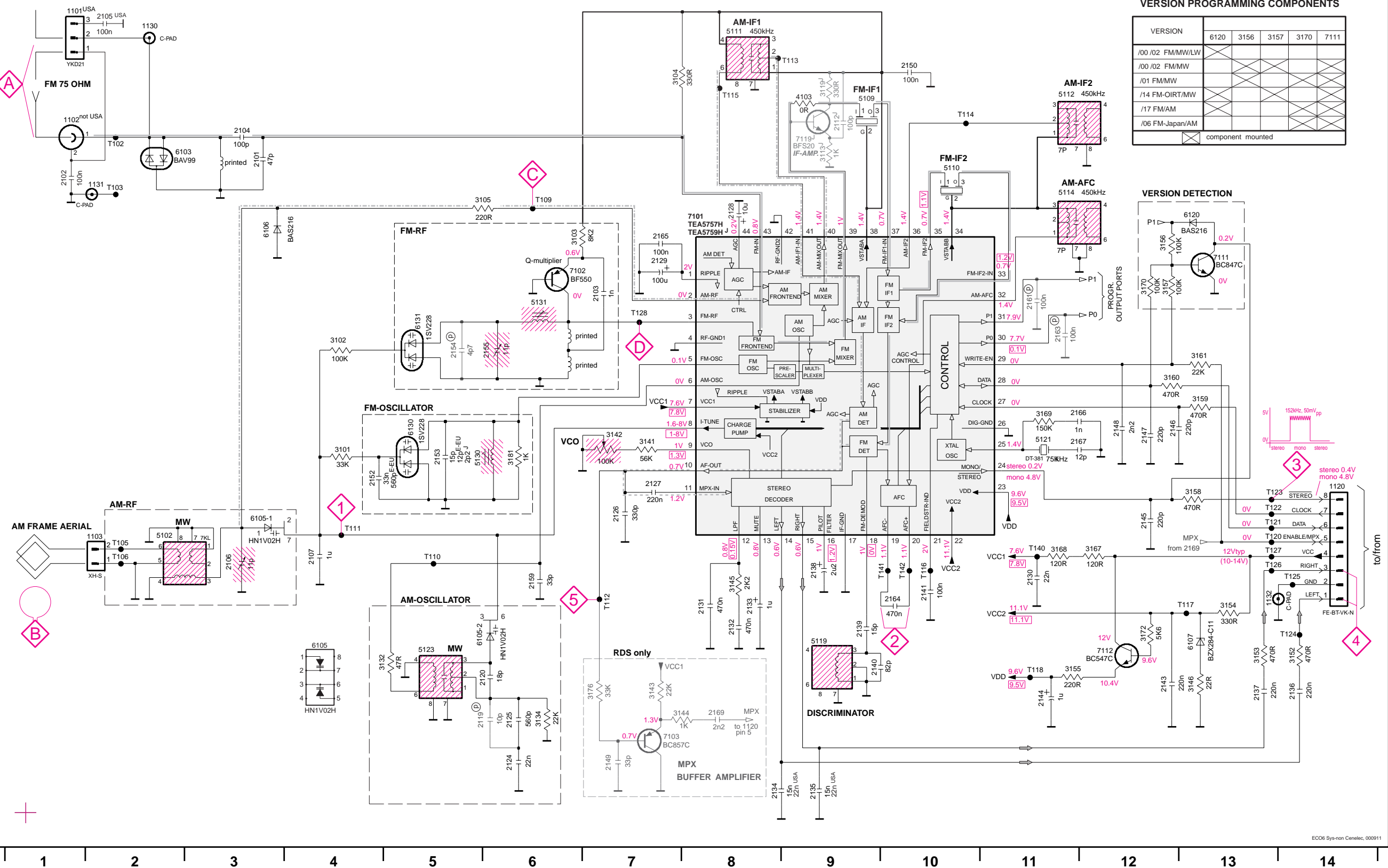

VERSION PROGRAMMING COMPONENTS

VERSION	6120	3156	3157	3170	7111
/00 /02 FM/MW/LW					
/00 /02 FM/MW					
/01 FM/MW					
/14 FM-OIRT/MW					
/17 FM/AM					
/06 FM-Japan/AM					

component mounted

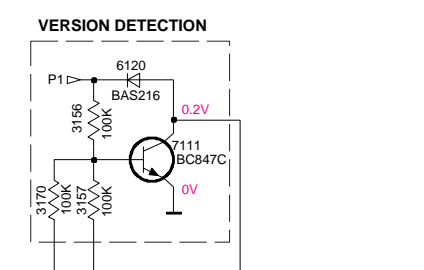

- 1101 A1
- 1102 B1
- 1103 F2
- 1120 E14
- 1130 A2
- 1131 B2
- 1132 G13
- 2101 B3
- 2102 B1
- 2103 C7
- 2104 B3
- 2105 A2
- 2106 F3
- 2107 F4
- 2119 H6
- 2120 G6
- 2124 H6
- 2125 H6
- 2126 F7
- 2127 E7
- 2128 C8
- 2129 C7
- 2130 F11
- 2131 G8
- 2132 G8
- 2133 G8
- 2134 H8
- 2135 H9
- 2136 G14
- 2137 G13
- 2138 F9
- 2139 G9
- 2140 G9
- 2141 F10
- 2143 G12
- 2144 G11
- 2145 F12
- 2146 E12
- 2147 E12
- 2148 E12
- 2149 H7
- 2150 A10
- 2152 A4
- 2153 E5
- 2154 D5
- 2155 D5
- 2159 F6
- 2161 C11
- 2163 D11
- 2164 F10
- 2165 C7
- 2166 E11
- 2167 E11
- 2169 H8
- 3101 E4
- 3102 D4
- 3103 C6
- 3104 A7
- 3105 B6
- 3132 G5
- 3134 H6
- 3141 E7
- 3142 E7
- 3143 G7
- 3144 H7
- 3145 F8
- 3146 G13
- 3152 G14
- 3153 G13
- 3154 G13
- 3155 G11
- 3156 C12
- 3157 C12
- 3158 E13
- 3159 D13
- 3160 D12
- 3161 D13
- 3167 F12
- 3168 F11
- 3169 E11
- 3170 C12
- 3172 G12
- 3176 G7
- 3181 E6
- 5102 E2
- 5109 B9
- 5110 B10
- 5111 A8
- 5112 A11
- 5114 A11
- 5119 G9
- 5121 E11
- 5123 G5
- 5130 E5
- 5131 C6
- 5132 B2
- 6105 F3
- 6105-2 G5
- 6106 C3
- 6107 G13
- 6120 C13
- 6130 E5
- 6131 D5
- 7101 C8
- 7102 C6
- 7103 H7
- 7111 C13
- 7112 F13
- 7127 F13
- T102 B2
- T103 B2
- T105 F2
- T106 F2
- T109 B6
- T110 F5
- T111 F4
- T112 F7
- T113 A8
- T114 B10
- T115 A8
- T116 B10
- T117 G13
- T118 G13
- T119 B6
- T120 F13
- T121 F13
- T122 F13
- T123 F13
- T124 F13
- T125 F13
- T126 F13
- T127 F13
- T128 D7
- T140 F11
- T141 F10
- T142 F10

LEGEND
 (P) ... for provision only
 USA ... for USA version only
 E-EU ... for East European version only
 J ... for Japanese version only

...V FM mode stereo
 ...V MW mode
 ...V LW mode
 voltages measured while set is tuned to a strong transmitter

Signal path
 — FM
 - - - AM
 - - - MPX (Audio Frequency)
 ⇨ AF - left/right

1101 A6 1120 A4 1132 A5 2128 C4 2138 C2 3142 D2 5110 B3 5114 A2 5123 D5 7112 C1 9104 B5 9107 D4
 1102 B6 1130 B5 2106 C5 2129 B4 2144 B2 5102 D6 5111 B4 5119 C2 5130 D3 9101 A2 9105 B1 9108 C4
 1103 D6 1131 D5 2107 B5 2133 D2 2155 C4 5109 A3 5112 A3 5121 B2 5131 D4 9103 B2 9106 B3 9109 D2

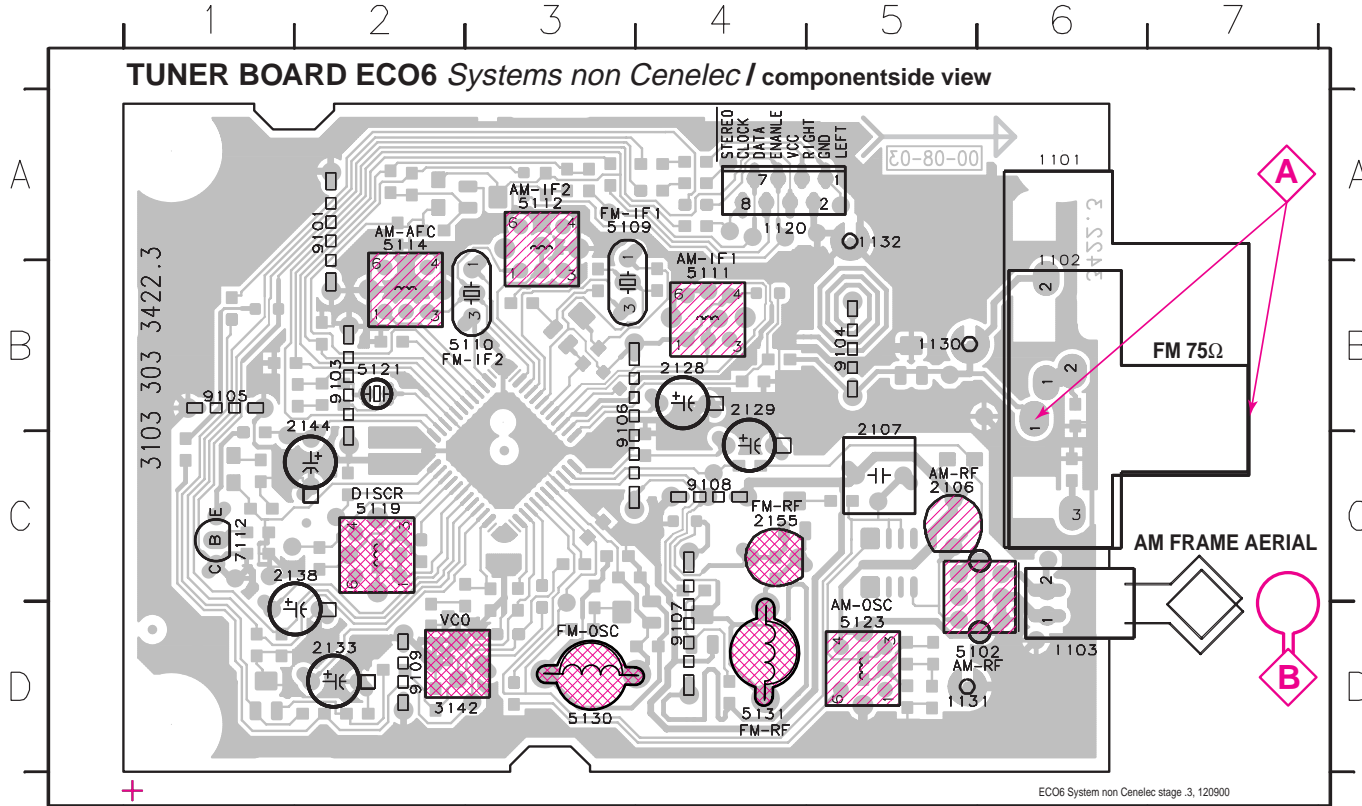

2101 B4 2119 D3 2130 D5 2137 A4 2146 B7 2153 C5 2165 C4 3103 C4 3134 D3 3152 A4 3158 A4 3169 B6 4106 C4 6107 C7 7103 D7
 2102 B1 2120 D3 2131 C5 2139 C6 2147 A5 2154 C4 2166 B6 3104 B4 3141 C5 3153 A4 3159 A5 3170 A6 4107 C5 6120 A6 7111 A5
 2103 D4 2124 D3 2132 D6 2140 C6 2148 B6 2159 C5 2167 B6 3105 C4 3143 D6 3154 C7 3160 A5 3172 C7 4108 C5 6130 D4 7119 B5
 2104 B4 2125 D3 2134 D7 2141 C6 2149 D6 2161 A6 2169 A4 3113 B5 3144 B7 3155 C7 3161 A5 3176 D6 6103 B3 6131 C4
 2105 C1 2126 D6 2135 D7 2143 C7 2150 B5 2163 B6 3101 D5 3119 B5 3145 C5 3156 A6 3167 B7 3181 D4 6105 C3 7101 C5
 2112 B5 2127 C5 2136 A4 2145 A5 2152 C5 3102 C3 3132 D5 3146 C7 3157 A6 3168 C7 4103 B5 6106 C3 7102 D4

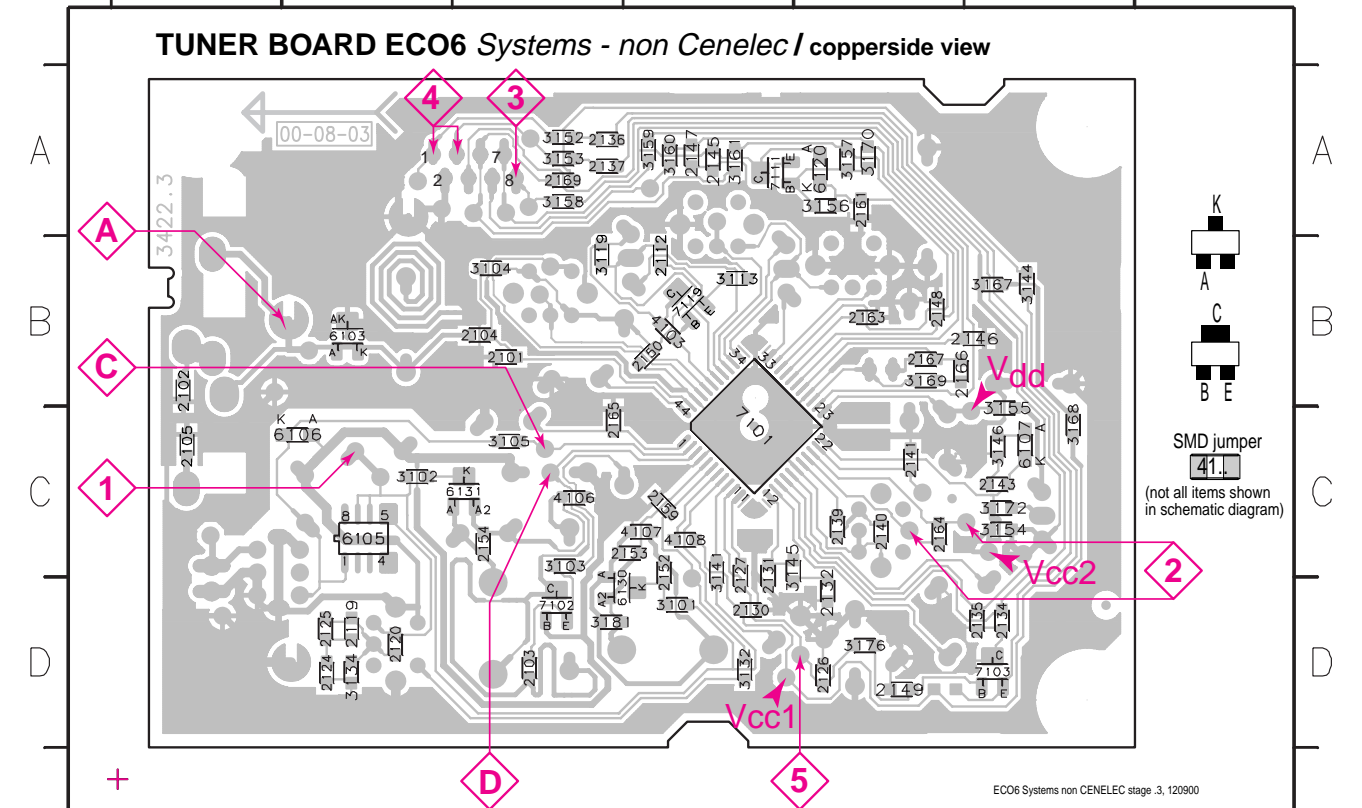

These assembly drawings show a summary of all possible versions.
 For components used in a specific version see schematic diagram respectively partlist.

TUNER ADJUSTMENT TABLE (ECO6 FM/MW- and FM/MW/LW - versions with AM-frame aerial)

Waverange	Input frequency	Input	Tuned to	Adjust	Output	Scope/Voltmeter
VARICAP ALIGNMENT						
FM 87.5 - 108MHz (65.81 - 74, 87.5 - 108MHz)	108MHz		108MHz	5130		8V ±0.2V
	87.5MHz (65.81MHz)		87.5MHz (65.81MHz)	check		4.3V ±0.5V (1.2V ±0.5V)
MW FM/AM-version, 10kHz grid 530 - 1700kHz	1700kHz		1700kHz	5123		8V ±0.2V
	530kHz		530kHz	check		1.1V ±0.4V
FM/MW-version, 9kHz grid 531 - 1602kHz	1602kHz		1602kHz	5123	1	6.9V ±0.2V
	531kHz		531kHz	check		1.1V ±0.4V
LW 153 - 279kHz	279kHz		279kHz	5122		8V ±0.2V
	153kHz		153kHz	check		1.1V ±0.4V
MW FM/MW/LW- version, 9kHz grid 531 - 1602kHz	1602kHz		1602kHz	5123		8V ±0.2V
	531kHz		531kHz	check		1.1V ±0.4V
FM IF						
FM	10.7MHz, 45mV continuous wave	D		5119	2	0 ± 3 mV DC
FM RF						
FM 87.5 - 108MHz (65.81 - 74, 87.5 - 108MHz)	108MHz	A	108MHz	2155	4	MAX
	87.5MHz (65.81MHz)	mod=1kHz Δf=±22.5kHz	87.5MHz (65.81MHz)	5131		
VCO						
FM	98MHz, 1mV continuous wave	A	98MHz	3142	3	152kHz ±1kHz ¹⁾
AM IF						
MW	450kHz connect pin 6 of IC 7101 (AM Osc.) with 3.3kΩ to Vcc	C		5111	5	
		C		5112		
AM AFC MW		C		5114	2	0 ± 2 mV DC
AM RF³⁾						
MW⁴⁾ FM/MW/LW- and FM/MW-version (9kHz grid)	1494kHz	B	1494kHz	2106	5	
	531 - 1602kHz		558kHz	5102		
LW	198kHz		198kHz	5103		
MW FM/AM-version, 10kHz grid 530 - 1700kHz	1500kHz	B	1500kHz	2106	5	
	560kHz		560kHz	5102		

Use Service Testprogram. By selecting the TUNER TEST test frequencies will be stored as preset frequencies automatically.

- 1) If sensitivity of frequency counter is too low adjust to max. channel separation (input signal: stereo left 90% + 9%, adjust output on right channel to minimum)
- 2) RC network serves for damping the IF-filter while adjusting the other one.
- 3) For AM RF adjustments the original frame antenna has to be used!
- 4) MW has to be aligned before LW.

↑ Repeat

MISCELLANEOUS

1101	2422 015 19376	SOCKET 2P CLICKFIT	USA only
1102	4822 267 10283	SOCKET COAX, IEC 75Ω	not USA
1103	4822 265 31184	JST CONNECTOR 2 POLE	
1120	4822 265 11515	FFC SOCKET, 8P	

CAPACITORS

2101	4822 126 13692	47pF	1%	63V	
2102	4822 126 13838	100nF	10%	50V	not USA
2103	5322 122 31647	1nF	10%	63V	
2104	5322 122 32531	100pF	5%	50V	
2105	4822 126 13838	100nF	10%	50V	USA only

2106	2020 800 00191	3-11pF TRIMCAP.,N450		
2107	4822 121 51319	1μF	20%	50V
2120	4822 126 13689	18pF	1%	63V
2124	5322 122 32654	22nF	10%	63V
2125	2020 552 96199	560pF	1%	50V

2126	5322 122 31863	330pF	5%	50V
2127	4822 126 14076	220nF	20%	25V
2128	4822 124 40248	10μF	20%	63V
2129	4822 124 41584	100μF	20%	10V
2130	5322 122 32654	22nF	10%	63V

2131	4822 126 13482	470nF	20%	16V	
2132	4822 126 13482	470nF	20%	16V	
2133	4822 124 21913	1μF	20%	63V	
2134	4822 126 13188	15nF	5%	63V	not USA
2134	5322 122 32654	22nF	10%	63V	USA only

2135	4822 126 13188	15nF	5%	63V	not USA
2135	5322 122 32654	22nF	10%	63V	USA only
2136	4822 126 14076	220nF	20%	25V	
2137	4822 126 14076	220nF	20%	25V	
2138	4822 124 22652	2,2μF	20%	50V	

2139	4822 126 14236	15pF	5%	50V
2140	4822 126 13695	82pF	1%	63V
2141	4822 126 13838	100nF	10%	50V
2143	4822 126 14076	220nF	20%	25V
2144	4822 124 21913	1μF	20%	63V

2145	4822 122 33575	220pF	5%	50V	
2146	4822 122 33575	220pF	5%	50V	
2147	4822 122 33575	220pF	5%	50V	
2148	4822 122 33127	2,2nF	10%	63V	
2149	5322 122 32659	33pF	5%	50V	RDS only

2150	4822 126 13838	100nF	10%	50V	
2152	4822 126 12105	33nF	5%	63V	not for East Europe
2152	5322 116 80853	560pF	5%	63V	for East Europe only
2153	4822 126 13486	15pF	2%	63V	not for East Europe
2153	4822 122 33926	12pF	2%	50V	for East Europe only

2155	2020 800 00191	3-11pF TRIMCAP.,N450		
2159	5322 122 32659	33pF	5%	50V
2164	4822 126 13482	470nF	20%	16V
2165	4822 126 13838	100nF	10%	50V
2166	5322 122 31647	1nF	10%	63V

2167	4822 122 33926	12pF	5%	50V	
2169	4822 122 33127	2,2nF	10%	63V	RDS only

RESISTORS

3101	4822 051 20333	33kΩ	5%	0,1W
3102	4822 117 10837	100kΩ	1%	0,1W
3103	4822 051 20822	8,2kΩ	5%	0,1W
3104	4822 117 13577	330Ω	1%	0,1W
3105	4822 117 11503	220Ω	5%	0,1W

3132	4822 051 20479	47Ω	5%	0,1W
3134	4822 051 20223	22kΩ	5%	0,1W
3141	4822 117 11148	56kΩ	1%	0,1W
3142	4822 100 12159	TRIMPOT. 100kΩ		

RESISTORS

3143	4822 051 20223	22kΩ	5%	0,1W	RDS only
3144	4822 051 10102	1kΩ	2%	0,25W	RDS only
3145	4822 117 11449	2,2kΩ	1%	0,1W	
3146	4822 051 20229	22Ω	5%	0,1W	
3152	4822 051 20471	470Ω	5%	0,1W	

3153	4822 051 20471	470Ω	5%	0,1W
3154	4822 117 13577	330Ω	1%	0,1W
3155	4822 117 11503	220Ω	5%	0,1W
3156	4822 117 10837	100kΩ	1%	0,1W
3157	4822 117 10837	100kΩ	1%	0,1W

3158	4822 051 20471	470Ω	5%	0,1W
3159	4822 051 20471	470Ω	5%	0,1W
3160	4822 051 20471	470Ω	5%	0,1W
3161	4822 051 20223	22kΩ	5%	0,1W
3167	4822 051 20121	120Ω	5%	0,1W

3168	4822 051 20121	120Ω	5%	0,1W	
3169	4822 051 20154	150kΩ	5%	0,1W	
3170	4822 117 10837	100kΩ	1%	0,1W	
3172	4822 051 20562	5,6kΩ	5%	0,1W	
3176	4822 051 20333	33kΩ	5%	0,1W	RDS only

3181	4822 051 10102	1kΩ	2%	0,25W
4103	4822 051 20008	CHIP JUMPER 0805		
4106	4822 051 20008	CHIP JUMPER 0805		
4107	4822 051 20008	CHIP JUMPER 0805		
4108	4822 051 20008	CHIP JUMPER 0805		

COILS

5102	4822 157 71634	RF-COIL MW
5109	4822 242 70665	FM-IF FILTER 10,7MHz
5110	4822 242 70665	FM-IF FILTER 10,7MHz
5111	2422 549 44023	AM-IF FILTER 450kHz
5112	4822 157 70302	AM-IF FILTER 450kHz

5114	4822 157 70302	AM-IF FILTER 450kHz
5119	4822 157 11443	DISCRIMINATOR COIL
5121	4822 242 10261	QUARTZ 75kHz
5123	2422 549 44108	RF-COIL, AM-OSCILLATOR
5130	4822 157 11843	RF COIL 1,5 TURNS

5131	4822 157 11843	RF COIL 1,5 TURNS
------	----------------	-------------------

DIODES

6103	5322 130 34337	BAV99
6105	4822 130 83075	HN1V02H
6106	4822 130 83757	BAS216
6107	9340 386 90115	BZX284-C11
6120	4822 130 83757	BAS216

6130	4822 130 82833	1SV228
6131	4822 130 82833	1SV228

TRANSISTORS

7102	4822 130 42131	BF550	
7103	5322 130 42756	BC857C	RDS only
7111	5322 130 42755	BC847C	
7112	4822 130 44503	BC547C	

INTEGRATED CIRCUITS

7101	9351 740 80557	TEA5757H/V1, RADIO IC
------	----------------	-----------------------

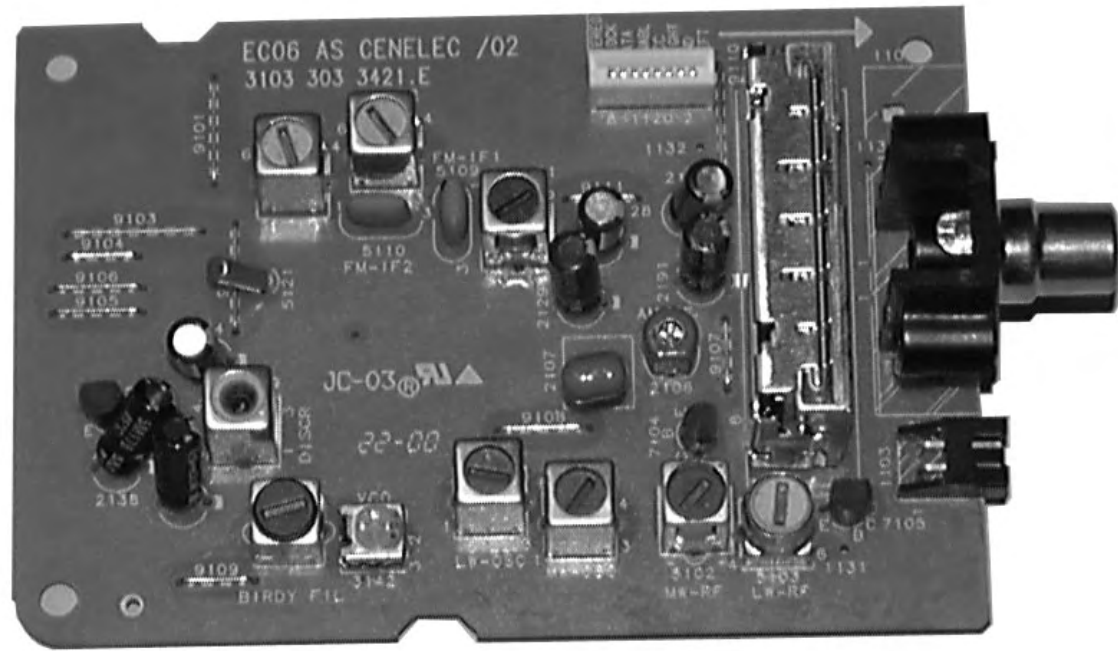

ECO6 Tuner Board

version: **SYSTEMS CENELEC**

TABLE OF CONTENTS

Blockdiagram.....	7B-1
Schematic Diagram.....	7B-2
Component Layout.....	7B-3
Adjustment table.....	7B-3
Electrical Partslist.....	7B-4

BLOCK DIAGRAM

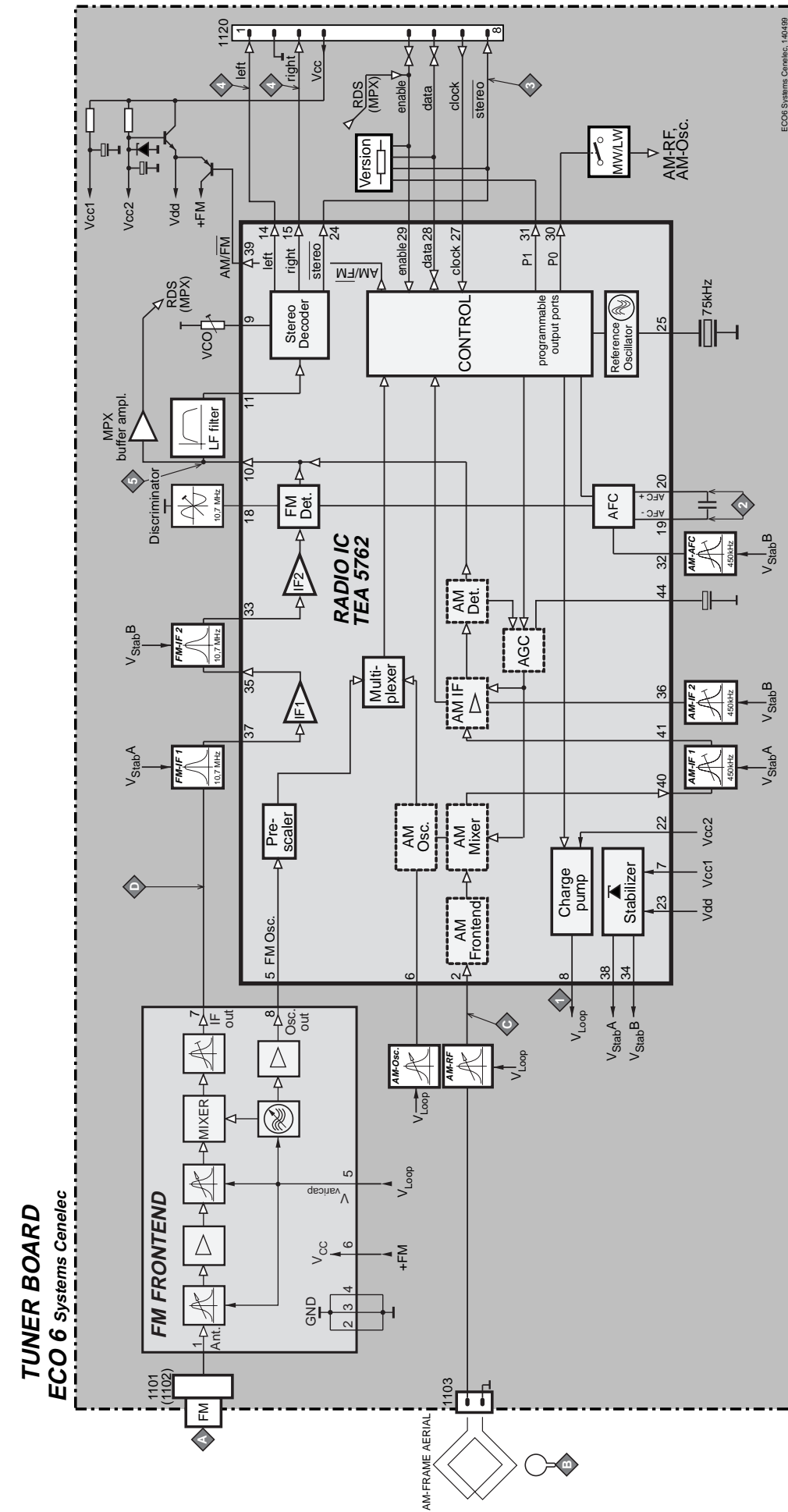

TUNER BOARD ECO6 / SYSTEMS-CENELEC

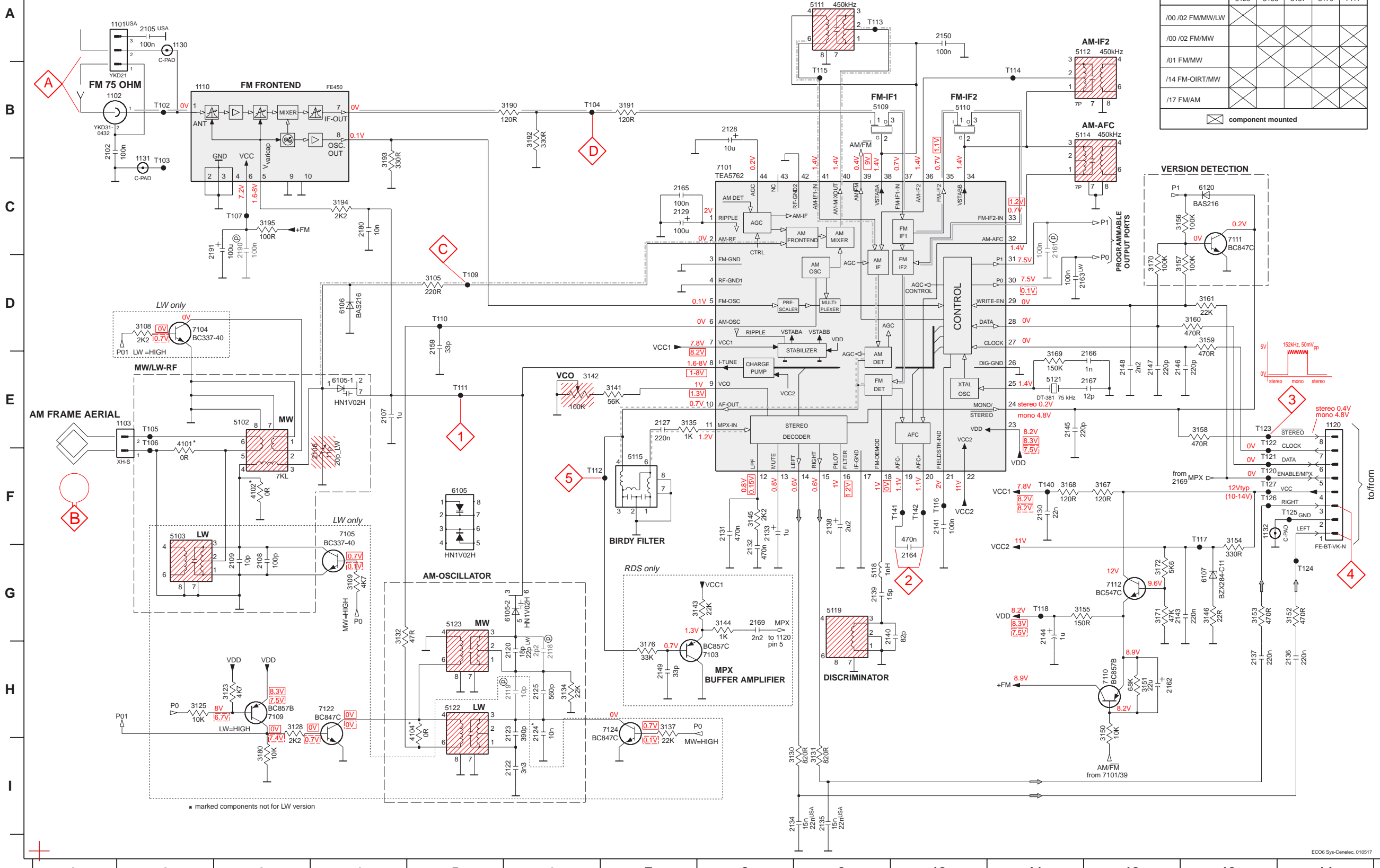

VERSION PROGRAMMING COMPONENTS

VERSION	6120	3156	3157	3170	7111
/00 /02 FM/MW/LW					
/01 FM/MW					
/14 FM-OIRT/MW					
/17 FM/AM					

⊗ component mounted

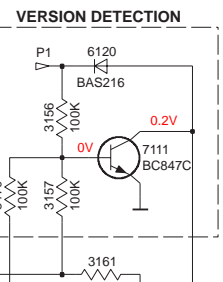

- 1101 A2
- 1102 B1
- 1103 E2
- 1110 B2
- 1120 E14
- 1130 A2
- 1131 C2
- 1132 F13
- 2102 B1
- 2105 A3
- 2106 E3
- 2107 E4
- 2108 G3
- 2109 G3
- 2118 H6
- 2119 H6
- 2120 H6
- 2122 I6
- 2123 H6
- 2124 H6
- 2125 H6
- 2127 E7
- 2128 B8
- 2129 C7
- 2130 F11
- 2131 F8
- 2132 F8
- 2133 F8
- 2134 I8
- 2135 I9
- 2136 H14
- 2137 H13
- 2138 F9
- 2139 G9
- 2140 G9
- 2141 F10
- 2143 G12
- 2144 G11
- 2145 E11
- 2146 E12
- 2147 E12
- 2148 E12
- 2149 H7
- 2150 A10
- 2159 D5
- 2161 C11
- 2162 H12
- 2163 D11
- 2164 G10
- 2165 C7
- 2166 E11
- 2167 E11
- 2169 G8
- 2180 C4
- 2190 C3
- 2191 C3
- 3105 D5
- 3108 D2
- 3109 G4
- 3123 H3
- 3125 H2
- 3128 H3
- 3130 I9
- 3131 I9
- 3132 G4
- 3134 H6
- 3135 E7
- 3137 H7
- 3142 E6
- 3143 G7
- 3144 G8
- 3145 F8
- 3146 G13
- 3150 H12
- 3151 H12
- 3152 G14
- 3153 G13
- 3154 F13
- 3155 G12
- 3156 C12
- 3157 D12
- 3158 E13
- 3159 D13
- 3160 D13
- 3161 D13
- 3167 F12
- 3168 F11
- 3169 E11
- 3170 D12
- 3171 G12
- 3172 G12
- 3176 H7
- 3180 I3
- 3190 B6
- 3191 B7
- 3192 B6
- 3193 B4
- 3194 C4
- 3195 C3
- 4101 E2
- 4102 F3
- 4104 H5
- 5102 E3
- 5103 F2
- 5109 B9
- 5110 B10
- 5111 A9
- 5112 A11
- 5114 B11
- 5115 E7
- 5118 G9
- 5119 G9
- 5121 E11
- 5122 H5
- 5123 G5
- 6105-1 E4
- 6105-2 G6
- 6106 D4
- 6107 G13
- 6120 C13
- 7101 C8
- 7103 H8
- 7104 D2
- 7105 F4
- 7109 H3
- 7110 H12
- 7111 C13
- 7112 G12
- 7122 H4
- 7124 H7
- 7102 B2
- 7104 B6
- 7105 E2
- 7106 E2
- 7107 C3
- 7109 D5
- 7110 D5
- 7111 E5
- 7112 F7
- 7113 A9
- 7114 B11
- 7116 F10
- 7117 F13
- 7118 G11
- 7120 F13
- 7121 F13
- 7122 E13
- 7123 E13
- 7124 G14
- 7125 F14
- 7126 F13
- 7127 F13
- 7140 F11
- 7141 F10
- 7142 F10

LEGEND

... only assembled in FM/AM-version
 ⊕...for provision only
 USA... for USA version only
 LW... for LW version only

SMD jumper
 41xx
 OR

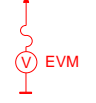

...V FM mode stereo
 ...V MW mode
 ...V LW mode
 voltages measured while set is tuned to a strong transmitter

Signal path

— FM
 - - - AM
 - · - · MPX (Audio Frequency)
 ⇨ AF - left/right

1101 B5 1110 B4 1131 C5 2107 B3 2133 C1 2162 A4 5102 C4 5110 A2 5114 A2 5121 B2 7104 C4 9101 A2 9104 B1 9107 B4 9110 A4
 1102 B5 1120 A4 1132 A4 2128 A3 2138 B1 2191 B4 5103 C4 5111 A3 5115 C2 5122 C3 7105 C5 9102 B2 9105 B1 9108 B3 9111 A3
 1103 C5 1130 A5 2106 B4 2129 B3 2144 B1 3142 C2 5109 B3 5112 A2 5119 B2 5123 C3 7112 B1 9103 A1 9106 B1 9109 C2

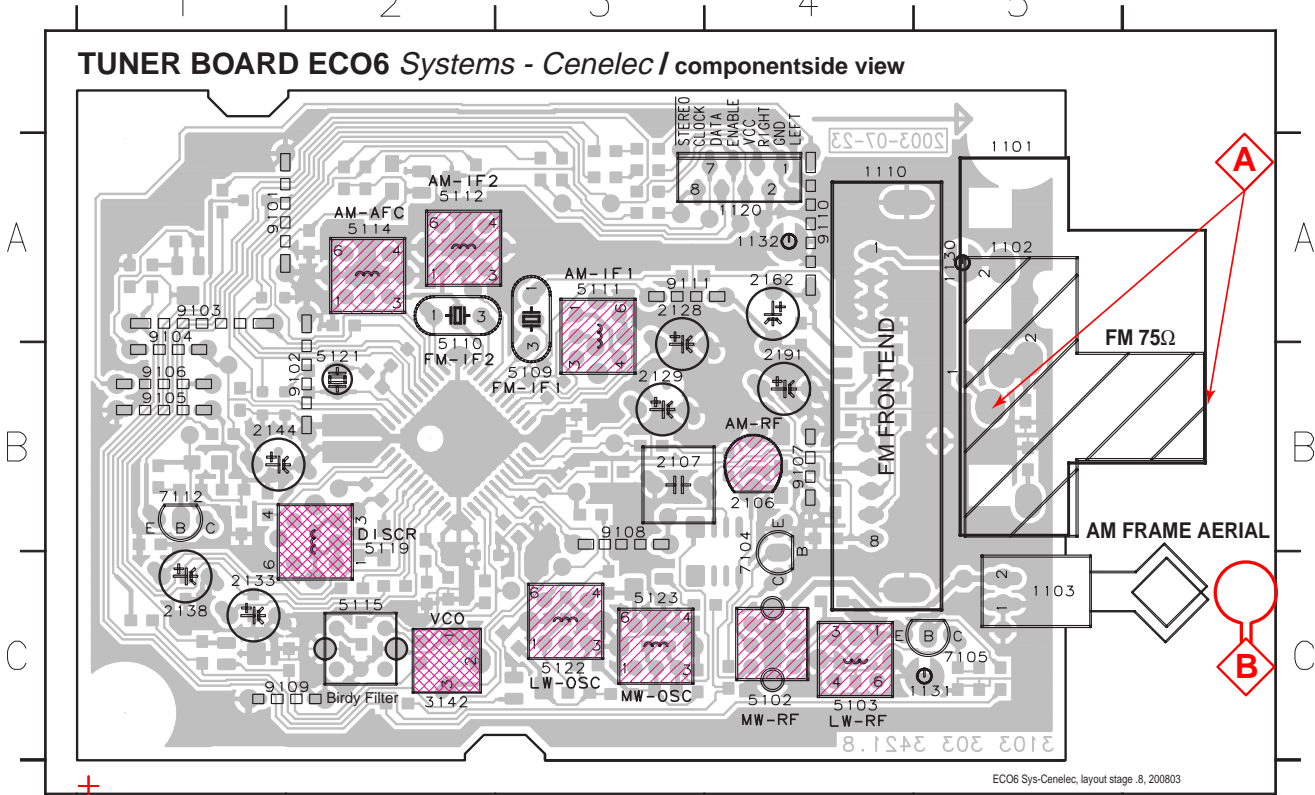

2102 B1 2120 C3 2130 B3 2137 A3 2146 B5 2161 A4 2169 A3 3123 A5 3134 C3 3145 C4 3154 B5 3160 A3 3171 B5 3192 A2 4104 C3 6106 B2 7110 B2
 2105 B1 2122 C3 2131 C4 2139 B4 2147 A5 2163 A4 2180 B2 3125 A5 3135 C4 3146 B5 3155 B5 3161 A4 3172 B5 3193 B2 4105 B2 6107 B5 7111 A4
 2108 C1 2123 C3 2132 C4 2140 B4 2148 B4 2164 B4 2190 B2 3128 C2 3137 C4 3150 B3 3156 A4 3167 A5 3176 C4 3194 B2 4106 B3 6120 A4 7122 C3
 2109 C1 2124 C3 2134 C5 2141 B5 2149 C4 2165 B3 3105 B3 3130 C4 3141 B3 3151 A2 3157 A4 3168 C5 3180 A5 3195 B2 4107 C4 7101 B4 7124 C3
 2118 C3 2125 C3 2135 C5 2143 B5 2150 B3 2166 B5 3108 C2 3131 C4 3143 C5 3152 A3 3158 A3 3169 B4 3190 B2 4101 C2 5118 C4 7103 C5
 2119 C3 2127 C4 2136 A3 2145 B5 2159 B3 2167 B4 3109 C1 3132 B3 3144 A5 3153 A3 3159 A3 3170 A4 3191 A3 4102 C2 6105 B2 7109 A5

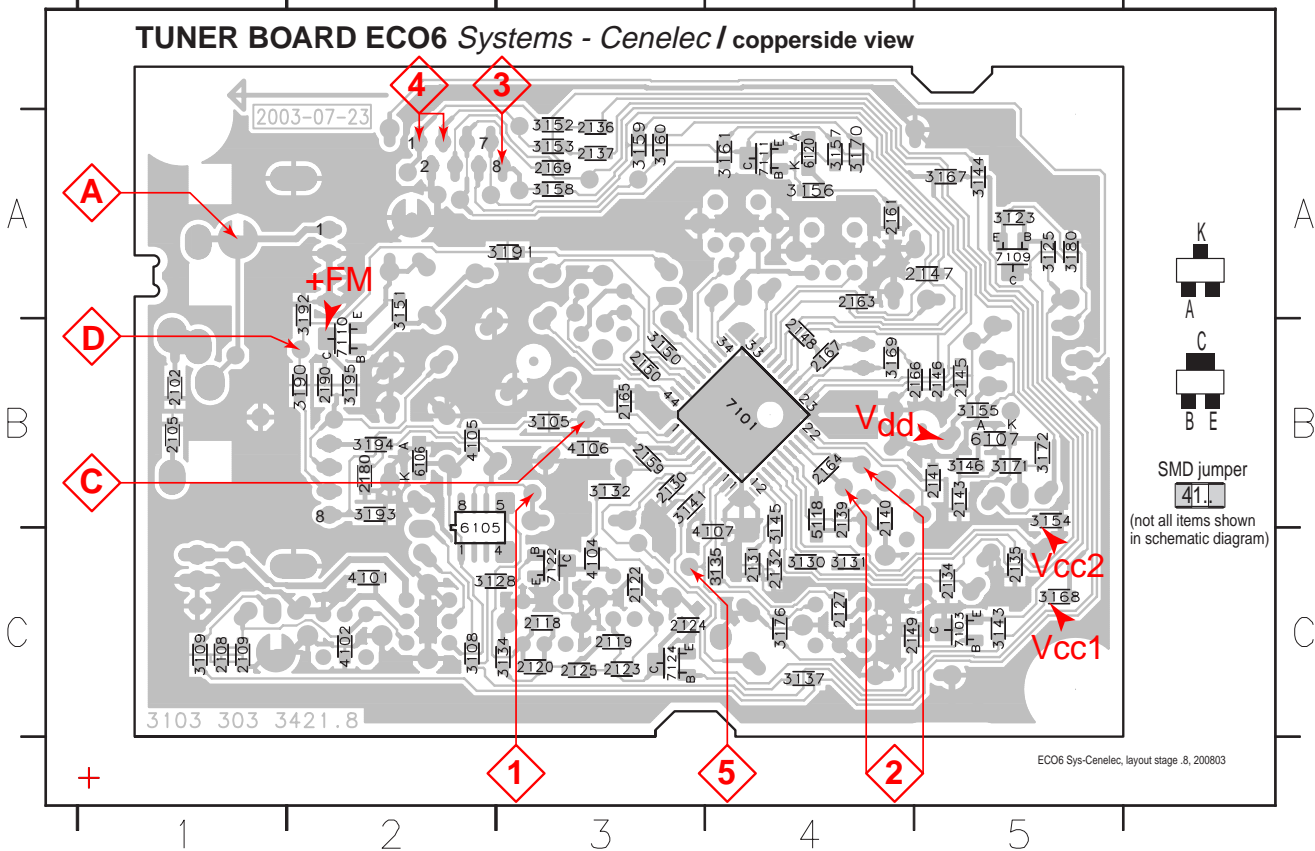

These assembly drawings show a summary of all possible versions.
 For components used in a specific version see schematic diagram respectively partslist.

TUNER ADJUSTMENT TABLE (ECO6 Cenelec FM/MW - and FM/MW/LW - versions with AM-frame aerial)

Waverange	Input frequency	Input	Tuned to	Adjust	Output	Scope/Voltmeter
VARICAP ALIGNMENT						
FM 87.5 - 108MHz (50kHz grid)			108MHz	check		8V ±1.2V
			87.5MHz	check		1.6V ±0.5V
MW 531 - 1602kHz (9kHz grid)			1602kHz	5123	1	8V ±0.2V 3-band 6.9V ±0.2V 2-band
			531kHz	check		1.1V ±0.4V
LW 153 - 279kHz (3kHz grid)			279kHz	5122		8V ±0.2V
			153kHz	check		1.1V ±0.4V
FM - IF						
FM	10.7MHz, 45mV continuous wave	D		5119	2	0mV ±3mV
FM - VCO						
FM	98MHz, 1mV continuous wave	A	98MHz	3142	3	152kHz ±1kHz ¹⁾
FM RF (channel separation) Note: The FM-frontend unit has already been adjusted by the factory and needs therefore no further adjustments for service purposes.						
FM	98MHz, 1mV 90% Left + 9% pilot mod=1kHz	A	98MHz	IF coil inside FM frontend 1110	4	right channel min.
AM IF						
MW	450kHz connect pin 6 of IC 7101 (AM Osc.) with 3.3kΩ to Vcc	C		5111	5	
				5112		
AM AFC MW		C		5114	2	0mV ±2mV
AM RF ³⁾						
MW	1494kHz	B	1494kHz	2106	5	
	558kHz					
LW	198kHz		198kHz	5103		

Use Service Testprogram. By selecting the TUNER TEST test frequencies will be stored as preset frequencies automatically.

- ¹⁾ If sensitivity of frequency counter is too low adjust to max. channel separation (input signal: stereo left 90% + 9%, adjust output on right channel to minimum)
- ²⁾ RC network serves for damping the IF-filter while adjusting the other one.
- ³⁾ For AM RF adjustments the original frame antenna has to be used!
 MW has to be aligned before LW.

↑ Repeat

MISCELLANEOUS

1101	2422 015 19376	SOCKET CLICKFIT 2P	USA only
1102	4822 267 10283	SOCKET COAX, IEC 75Ω	not USA
1103	4822 265 31184	JST CONNECTOR, 2 POLE	
1110	2422 542 90071	FM FRONTEND	
1120	4822 265 11515	FFC SOCKET, 8P	

CAPACITORS

2102©	4822 126 13838	100nF 10%	50V	not USA
2105©	4822 126 13838	100nF 10%	50V	USA only
2106	2020 800 00204	TRIMCAP. 4,2 - 20pF, N750		LW only
2106	2020 800 00191	TRIMCAP. 3 - 11pF, N450		FM/AM only
2107	4822 121 51319	1μF 20%	50V	
2108©	5322 122 32531	100pF 5%	50V	LW only
2109©	5322 122 32448	10pF 5%	50V	LW only
2120©	4822 126 13689	18pF 1%	63V	FM/AM only
2120©	5322 122 32658	22pF 5%	50V	LW only
2122©	4822 122 33891	3,3nF 10%	63V	LW only

2123©	2020 552 93494	390pF 1%	50V	LW only
2124©	4822 122 33177	10nF 20%	50V	FM/AM only
2125©	2020 552 96199	560pF 1%	50V	
2127©	4822 126 14076	220nF 20%	25V	
2128	4822 124 40248	10μF 20%	63V	

2129	4822 124 41584	100μF 20%	10V	
2130©	5322 122 32654	22nF 10%	63V	
2131©	4822 126 13482	470nF 20%	16V	
2132©	4822 126 13482	470nF 20%	16V	
2133	4822 124 21913	1μF 20%	63V	

2134©	3198 017 31530	15nF 10%	50V	not USA
2134©	5322 122 32654	22nF 10%	63V	USA only
2135©	3198 017 31530	15nF 10%	50V	not USA
2135©	3198 017 32230	22nF 10%	25V	USA only
2136©	4822 126 14076	220nF 20%	25V	

2137©	4822 126 14076	220nF 20%	25V	
2138	4822 124 22652	2,2μF 20%	50V	
2139©	4822 126 14236	15pF 5%	50V	
2140©	4822 126 13695	82pF 1%	63V	
2141©	4822 126 13838	100nF 10%	50V	

2143©	4822 126 14076	220nF 20%	25V	
2144	4822 124 21913	1μF 20%	63V	
2145©	4822 122 33575	220pF 5%	50V	
2146©	4822 122 33575	220pF 5%	50V	
2147©	4822 122 33575	220pF 5%	50V	

2148©	4822 122 33127	2,2nF 10%	63V	
2149©	5322 122 32659	33pF 5%	50V	RDS only
2150©	4822 126 13838	100nF 10%	50V	
2159©	5322 122 31151	22μF 20%	50V	

2163©	4822 126 13838	100nF 10%	50V	LW only
2164©	4822 126 13482	470nF 20%	16V	
2165©	4822 126 13838	100nF 10%	50V	
2166©	5322 122 31647	1nF 10%	63V	
2167©	4822 122 33926	12pF 5%	50V	

2169©	4822 122 33127	2,2nF 10%	63V	RDS only
2180©	3198 017 31030	10nF 10%	50V	
2190©	4822 126 13838	100nF 10%	50V	
2191	4822 124 40178	100μF 20%	10V	

RESISTORS

3105©	4822 117 11503	220Ω 5%	0,1W	
3108©	4822 117 11449	2,2kΩ 1%	0,1W	LW only
3109©	4822 051 20472	4,7kΩ 5%	0,1W	LW only
3123©	4822 051 20472	4,7kΩ 5%	0,1W	LW only
3125©	4822 117 10833	10kΩ 1%	0,1W	LW only

RESISTORS

3128©	4822 117 11449	2,2kΩ 1%	0,1W	LW only
3130©	3198 021 38210	820Ω 5%	0,06W	
3131©	3198 021 38210	820Ω 5%	0,06W	
3132©	4822 051 20479	47Ω 5%	0,1W	
3134©	4822 051 20223	22kΩ 5%	0,1W	

3135©	3198 021 31020	1kΩ 5%	0,06W	
3137©	4822 051 20223	22kΩ 5%	0,1W	LW only
3141©	4822 117 11148	56kΩ 1%	0,1W	
3142	4822 100 12159	TRIMPOT. 100kΩ		
3143©	4822 051 20223	22kΩ 5%	0,1W	RDS only

3144©	4822 051 10102	1kΩ 2%	0,25W	RDS only
3145©	4822 117 11449	2,2kΩ 1%	0,1W	
3146©	4822 051 20229	22Ω 5%	0,1W	
3150©	4822 117 10833	10kΩ 1%	0,1W	
3151©	4822 051 20683	68kΩ 5%	0,1W	

3152©	4822 051 20471	470Ω 5%	0,1W	
3153©	4822 051 20471	470Ω 5%	0,1W	
3154©	4822 117 13577	330Ω 1%	0,1W	
3155©	4822 117 10353	150Ω 5%	0,1W	
3156©	4822 117 10837	100kΩ 1%	0,1W	

3157©	4822 117 10837	100kΩ 1%	0,1W	
3158©	4822 051 20471	470Ω 5%	0,1W	
3159©	4822 051 20471	470Ω 5%	0,1W	
3160©	4822 051 20471	470Ω 5%	0,1W	
3161©	4822 051 20223	22kΩ 5%	0,1W	

3167©	4822 051 20121	120Ω 5%	0,1W	
3168©	4822 051 20121	120Ω 5%	0,1W	
3169©	4822 051 20154	150kΩ 5%	0,1W	
3170©	4822 117 10837	100kΩ 1%	0,1W	
3171©	4822 117 10834	47kΩ 1%	0,1W	

3172©	4822 051 20562	5,6kΩ 5%	0,1W	
3176©	4822 051 20333	33kΩ 5%	0,1W	RDS only
3180©	4822 117 10833	10kΩ 1%	0,1W	LW only
3190©	4822 051 20121	120Ω 5%	0,1W	
3191©	4822 051 20121	120Ω 5%	0,1W	

3192©	4822 117 13577	330Ω 1%	0,1W	
3193©	4822 117 13577	330Ω 1%	0,1W	
3194©	4822 117 11449	2,2kΩ 1%	0,1W	
3195©	4822 051 20101	100Ω 5%	0,1W	
4101©	4822 051 20008	CHIP JUMPER 0805		FM/AM only

4102©	4822 051 20008	CHIP JUMPER 0805		FM/AM only
4104©	4822 051 20008	CHIP JUMPER 0805		FM/AM only
4105©	4822 051 20008	CHIP JUMPER 0805		
4106©	4822 051 20008	CHIP JUMPER 0805		
4107©	4822 051 20008	CHIP JUMPER 0805		

COILS

5102	4822 157 71634	RF-COIL MW		
5103	2422 549 44107	RF-COIL LW		LW only
5109	4822 157 71639	FM-IF FILTER 10,7MHz		
5110	4822 242 70665	FM-IF FILTER 10,7MHz		
5111	2422 549 44023	AM-IF FILTER 450kHz		

5112	4822 157 70302	AM-IF FILTER 450kHz		
5114	4822 157 70302	AM-IF FILTER 450kHz		
5115	4822 157 71636	ANTI BIRDY FILTER		
5118©	2422 535 95881	100nH		
5119	4822 157 11443	DISCRIMINATOR COIL		

5121	4822 242 10261	QUARTZ 75kHz		
5122	2422 549 44108	RF-COIL, LW-OSCILLATOR		LW only
5123	2422 549 44108	RF-COIL, MW-OSCILLATOR		

DIODES

6105©	4822 130 83075	HN1V02H		
6106©	4822 130 83757	BAS216		
6107©	9340 386 90115	BZX284-C11		
6120©	4822 130 83757	BAS216		

TRANSISTORS

7103©	5322 130 42756	BC857C		RDS only
7104	9322 003 64676	TBC337-40		LW only
7105	9322 003 64676	TBC337-40		LW only
7109©	4822 130 60373	BC856B		LW only
7110©	4822 130 60373	BC856B		

7111©	5322 130 42755	BC847C		
7112	4822 130 44503	BC547C		
7122©	5322 130 42755	BC847C		LW only
7124©	5322 130 42755	BC847C		LW only

INTEGRATED CIRCUITS

7101	4822 209 90315	TEA5762H/V1, RADIO IC		
------	----------------	-----------------------	--	--

ETF7 TAPE MODULE

(Non-Dolby Version)

TABLE OF CONTENTS

Tape Module Wiring & variation table 9-1
 Block diagram 9-2
 Brief Introduction 9-3
 Connector assignment 9-4
 Tape deck electronics & Tape adjustments 9-5
 ETF7 Non-Dolby board layouts 9-6
 Analog Circuit diagram 9-7
 Servo Circuit diagram 9-8
 Exploded views & parts list 9-9
 Electrical parts list 9-13

Tapedeck wiring (Double deck)

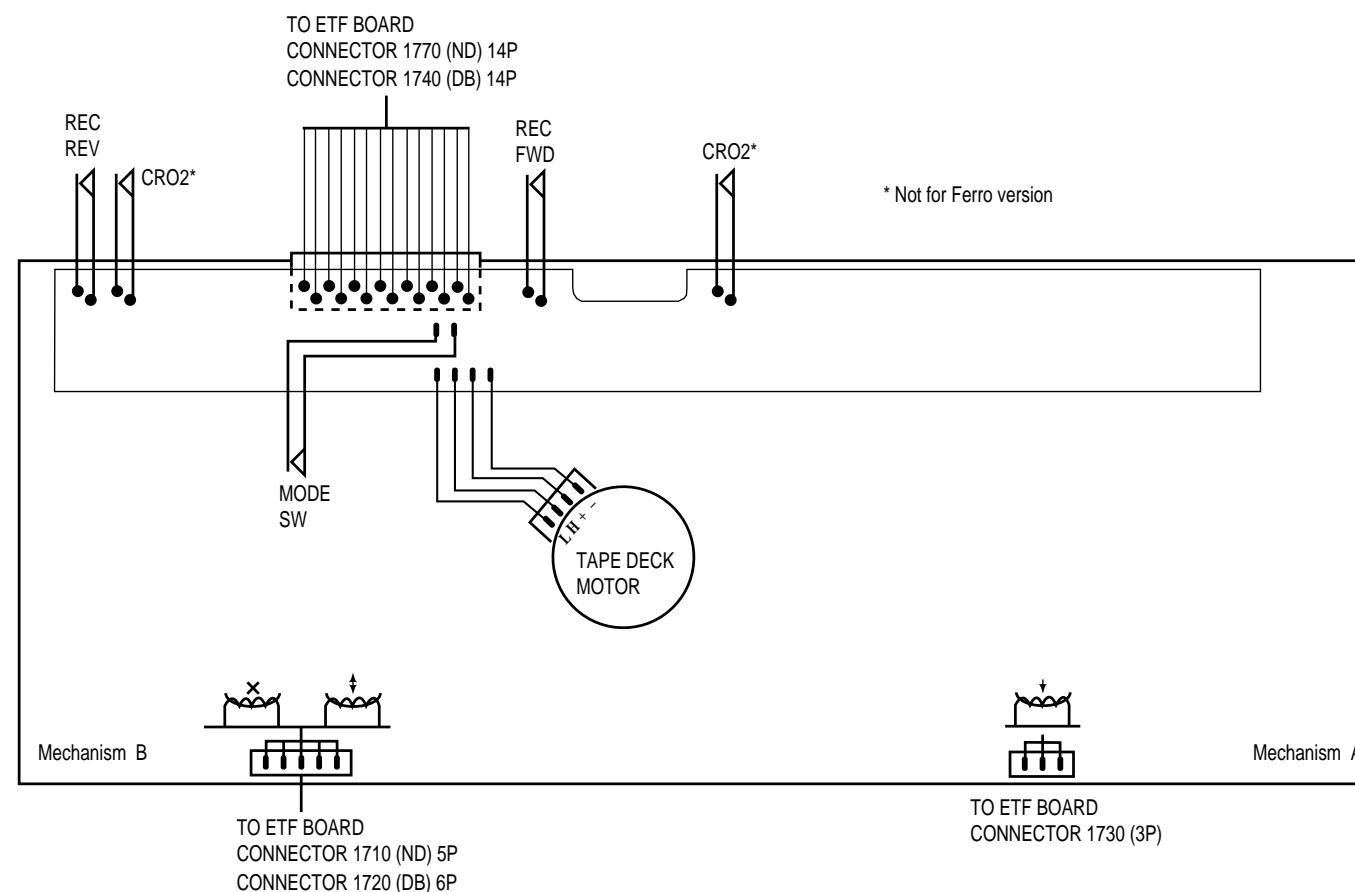

Variations table for Analog Circuit

	Non-autoreverse ND/DD/FF		
	Autoreverse ND/DD/FR	Chrome/Ferro	Ferro
2624	-	-	100nF
2701 , 2702	150pF	270pF	270pF
2703 , 2704	100pF	220pF	220pF
2717 , 2718	10nF	15nF	15nF
2721 , 2722	6,8nF	6,8nF	-
2727 , 2728	470pF	1nF	1nF
3616	10k	1k	1k
3618	6k8	-	-
3620	10k trimmer	-	-
3622	-	10k trimmer	10k trimmer
3672	4k7	-	-
3676	47k	-	-
3687	220R	220R	-
3688	680R	-	-
3723 , 3724	15k	18k	18k
3725 , 3726	10R	10R	-
3727 , 3728	5k6	6k8	6k8
3729 , 3730	3k3	4k7	4k7
3743 , 3744	1k5	2k2	2k2
3745 , 3746	3k3	5k6	5k6
3754 , 3755	1M	47R	47R

	Non-autoreverse ND/DD/FF		
	Autoreverse ND/DD/FR	Chrome/Ferro	Ferro
3769	12k	8k2	8k2
3772	6k8	5k6	5k6
4785	-	-	OR jumper
3774	15k	8k2	8k2
6614	1N4148	-	-
7616	BC857B	-	-
7622	BC847B	-	-

BLOCK DIAGRAM

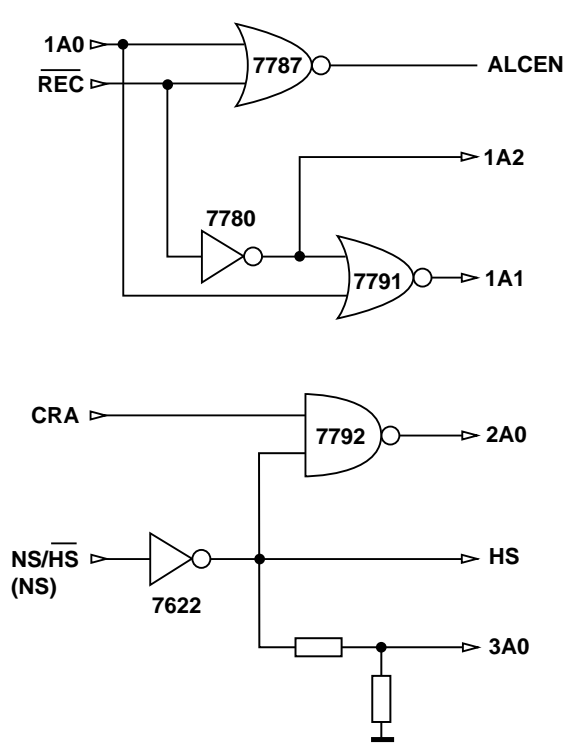
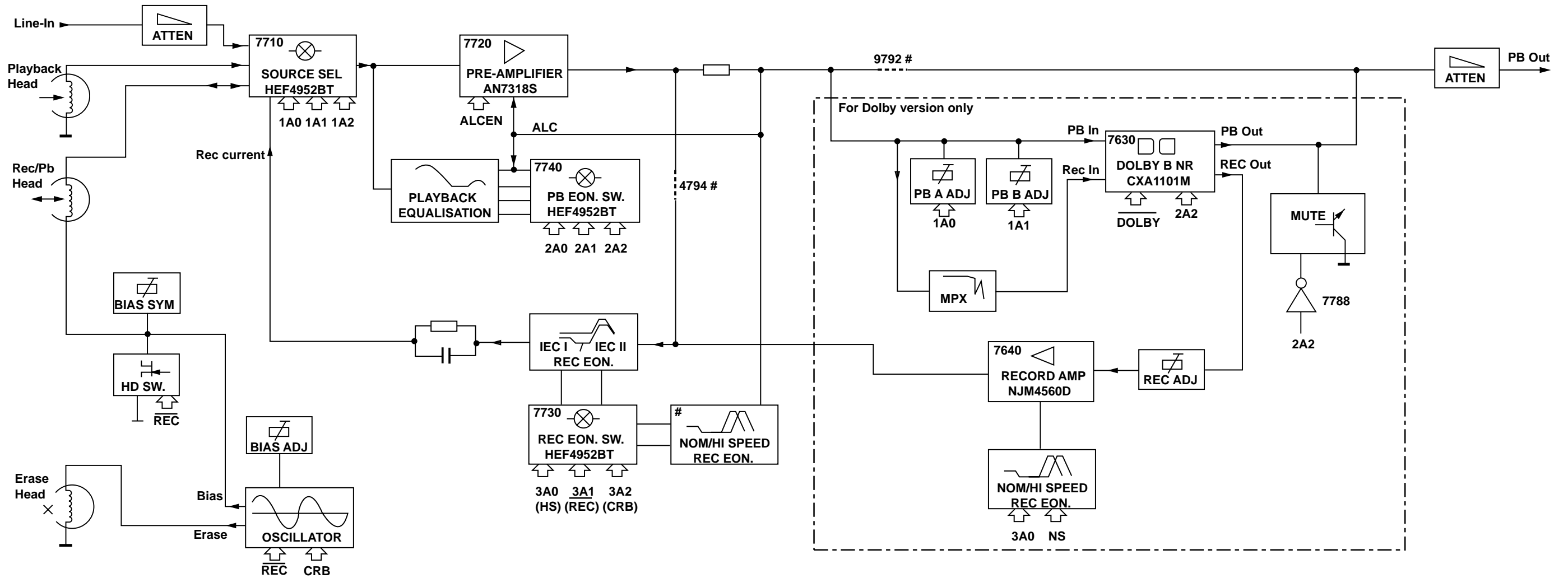

NOTE: # For Non-dolby version only
Only 1 channel is presented.

MicroProcessor Control / Communication lines

Direct / Indirect Control lines from Shift Registers

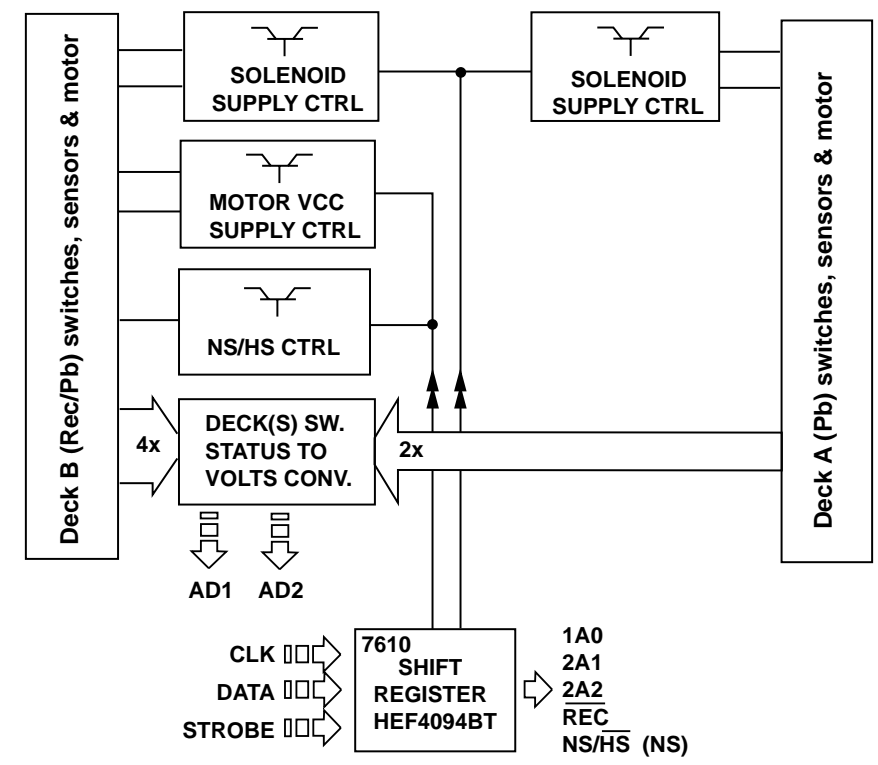

Brief introduction

General

1. Playback Mode
Signal from the playback head Deck A or Deck B is selected and fed through by the Mode Selector IC7710 (HEF4952BT). The signal is amplified by amplifier IC7720 (AN7323S) before feeding to the IC7740 (HEF4952BT) and out to the AF Board via connector 1701.
2. Recording Mode
Recording Signal is selected and fed through by the Mode Selector IC7710 (HEF4952BT) which is then amplified by the amplifier IC7720 (AN7323S). The amplified output signal will pass through IC7730 (HEF4952BT) for record equalization and back to IC7710 (HEF4952BT) before registered into the Rec/PB Head of Deck B.
3. Dubbing Mode
In Dubbing mode, signal from the playback head Deck A is selected and fed through by the Mode Selector IC7710 (HEF4952BT) which is then equalised for playback mode by the amplifier IC7720 (AN7323S) so that a flat response is obtained after the pre-amp. The equalised signal will then follow the same path as in the Recording mode.
4. Mode Selector
The Mode Selector IC7710 (HEF4952BT) caters for 4 inputs signal, namely Playback Signal from Deck A, Playback Signal from Deck B, Recording Signal and Dubbing Signal.
5. Amplifier PB/REC
Amplifier IC7720 (AN7323S) is for the purpose of amplifying the Playback and Recording signal from the Mode Selector.
6. Automatic Level Control (ALC)
ALC circuit consists of resistors (3760, 3765, 3766, 3767), capacitors (2762, 2763) and control by transistor 7787 (BC847B). ALC limits the amplifier output to a constant value when input signal becomes too large, thus limiting recording current to below saturation level, to prevent recording distortion.
7. Muting Circuit (For Non-Dolby version only)
Switch S4 of the IC7740 (HEF4952BT) is for the purpose of muting the output during Recording mode. During Recording mode, S4 is closed and shorted to the ground.
8. IC7740 (HEF4952BT)
The function of the IC7740 (HEF4952BT) is to change time constant between 120us Ferro (IEC I) and 70us Chrome (IEC II) during playback mode. It will automatically determined whether the tape type is 120us Ferro (IEC I) or 70us Chrome (IEC II). This IC will switch to Flat Gain during the Recording mode.
9. IC7730 (HEF4952BT)
The function of the IC7730 (HEF4952BT) is to change gain and time constant according to tape type and recording speed to boost recording current at higher frequency during recording to compensate for head loss. It will automatically determined whether the tape type is 120us Ferro (IEC I) or 70us Chrome (IEC II).
10. Bias Level
Bias Level making use of the Variable resistor (3773) for adjusting the optimal level of the bias current for Ferro or Chrome.
11. Bias Symm (For Dolby B NR version only)
Bias Symm making use of the Variable resistor (3785) to adjust the bias current for the left and the right channel to be equal.
12. PB Switch
Playback Switch which consists of the FETs 7785 (For Dolby B NR version only) & 7786 (J111) is for the purpose of providing a virtual ground for the Rec/PB Head (Deck B) during Playback mode. During the Playback mode, the FETs are turn on and shorted pin 2 and 4 of connector 1720 to the ground. During Recording mode, the FETs are turn off to allow the oscillator signal to be superposition onto the Recording signal for recording.

13. Motor Speed (For FR versions only)
During High speed dubbing, a feedback signal from the uP through pin 03 of the IC7610 (HEF4094BT) will trigger the transistors 7622 (BC847B) and 7616 (BC857B) to cause a change in the voltage level between High and Low, thus changing the speed of the motor.
14. IC7610 (HEF4094BT)
IC7610 (HEF4094BT) is a Shift Register use for issues the logic for cmos switch ICs (HEF4952BT) via 1A0, 2A1 and 2A2. It also issues logic to On/Off SOL_A, SOL_B and MOT. Recording speed is controlled via NS/HS.

Dolby Circuit (For sets with Dolby B NR version only)

15. IC7630 (CXA1551M)
IC7630 (CXA1551M) in the Dolby circuit is a Dolby Noise Reduction Type B IC for the Playback and Recording signal. Noise Reduction ON/OFF are controlled by $\overline{\text{DOLBY}}$, which is from CLK, direct from uP. After clocking in DATA, CLK is set to HIGH/LOW for NR OFF/ON.
16. 19kHz Filter
The 19kHz filters 5631 & 5632 (LXD-210) in the Dolby circuit is for the purpose of filtering the 19kHz Pilot Tone (for Tuner signal only) of the Recording signal.
17. Level Adjust
The Variable resistor 3635, 3636, 3641 and 3642 in the Dolby circuit is for adjusting the playback level of the Dolby reference (400Hz, 200nWb/m). Transistor 7631, 7632 are ON to enable adjustment of 3641, 3642 during Playback Deck A. Transistor 7633, 7634 and 3635, 3636 are active for Playback Deck B.
18. Amplifier IC7640 (NJM4560M)
The Amplifiers 7640A & 7640B (NJM4560M) in the Dolby circuit is for the purpose of amplified the Recording signal.
19. Muting Circuit
The muting circuit which consists of transistors 7788, 7789 and 7790 (BC847B) is for the purpose of muting the output during Recording mode.

NOTATIONS & ABBREVIATIONS USED IN THIS DOCUMENT

CR	Chrome (IEC type II)
DB	Dolby NR type B
DD	Double Deck
DM	Double Motor
FE	Ferro (IEC type I)
FF	Non-Autoreverse
FR	Autoreverse Deck B
Gnd x	Ground x
HSD	High speed dubbing
ND	Non Dolby
NR	Noise Reduction
NSD	Normal speed dubbing
PB	Playback
REC	Record
S/A	Sub-assy
SD	Single Deck
SM	Single Motor

CONNECTORS ASSIGNMENTS:CONNECTOR 1701INTERCONNECTION TO AF BOARD

○ 1	REC-L	Record input left
○ 2	REC-R	Record input right
○ 3	GND A	AF Ground
○ 4	TAPE-L	Playback output left
○ 5	+12V	D.C. supply (+12V) for AF electronics
○ 6	TAPE-R	Playback output right
○ 7	-CMOS	Negative d.c. supply (-9V) for CMOS ICs

CONNECTOR 1703INTERCONNECTION TO AF BOARD

○ 1	GND M	Motor Ground
○ 2	+MOTOR	D.C. supply (+12V) for tape deck motor & solenoid

CONNECTOR 1706INTERCONNECTION TO FRONT BOARD

○ 1	AD2	Deck sensing switches output voltage / Deck A EOT
○ 2	AD1	Deck sensing switches output voltage / Deck B EOT
○ 3	+5V	DC supply +5V for ADC network
○ 4	GND P	Control & Oscillator Ground
○ 5	CLK	HEF4094BT shift register Clock line
○ 6	DATA	HEF4094BT shift register Data line
○ 7	STROBE	HEF4094BT shift register Strobe line

CONNECTOR 1710DECK B HEADS CONNECTON (For Non-Dolby version only)

○ 1	B R/P HD L+	R/P Head left channel positive
○ 2	GND A	R/P Head return ground
○ 3	B R/P HD R+	R/P Head right channel positive
○ 4	ERASE HEAD	Erase Head
○ 5	GND A	Erase Head ground

CONNECTOR 1720DECK B HEADS CONNECTON (For Dolby B NR version only)

○ 1	B R/P HD L+	R/P Head left channel positive
○ 2	B R/P HD L-	R/P Head left channel negative
○ 3	B R/P HD R+	R/P Head right channel positive
○ 4	B R/P HD R-	R/P Head right channel negative
○ 5	ERASE HEAD	Erase Head
○ 6	GND A	Erase Head ground

CONNECTOR 1730DECK A HEAD CONNECTIONS (For Double Deck versions only)

○ 1	A PB HD L+	Pb Head left channel positive
○ 2	GND A	Pb Head return ground shield
○ 3	A PB HD R+	Pb Head right channel positive

CONNECTOR 1740DECK A & B CONTROL INTERFACE (For Dolby B NR version only)

○ 1	REC REW	Record tab protection status switch (reverse)	[open=on: close=off]
○ 2	CrO2 B	Chrome tape detection switch deck B	[open=Cr: close=Fe]
○ 3	REC FWD	Record tab protection status switch (forward)	[open=on: close=off]
○ 4	PHOTO B	Photo sensor output (tape movement indication)	
○ 5	SOL B	Solenoid supply for deck B	
○ 6	Vcc	Deck / Motor supply	
○ 7	MODE B	Mode switch (head engagement)	[open=off: close=engaged]
○ 8	GND M	Deck / Motor ground	
○ 9	SOL A	Solenoid supply for deck A	
○ 10	PHOTO A	Photo sensor output (tape movement indication)	
○ 11	MODE A	Mode switch (head engagement)	[open=off: close=engaged]
○ 12	L	L pin for motor	
○ 13	CrO2 A	Chrome tape detection switch deck A	[open=Cr: close=Fe]
○ 14	H	H pin for motor	

CONNECTOR 1770DECK A & B CONTROL INTERFACE (For Non-Dolby version only)

○ 1	REC REW	Record tab protection status switch (reverse)	[open=on: close=off]
○ 2	CrO2 B	Chrome tape detection switch deck B	[open=Cr: close=Fe]
○ 3	REC FWD	Record tab protection status switch (forward)	[open=on: close=off]
○ 4	PHOTO B	Photo sensor output (tape movement indication)	
○ 5	SOL B	Solenoid supply for deck B	
○ 6	Vcc	Deck / Motor supply	
○ 7	MODE B	Mode switch (head engagement)	[open=off: close=engaged]
○ 8	GND M	Deck / Motor ground	
○ 9	SOL A	Solenoid supply for deck A	
○ 10	PHOTO A	Photo sensor output (tape movement indication)	
○ 11	MODE A	Mode switch (head engagement)	[open=off: close=engaged]
○ 12	L	L pin for motor	
○ 13	CrO2 A	Chrome tape detection switch deck A	[open=Cr: close=Fe]
○ 14	H	H pin for motor	

TAPE MECHANISM ELECTRONICS

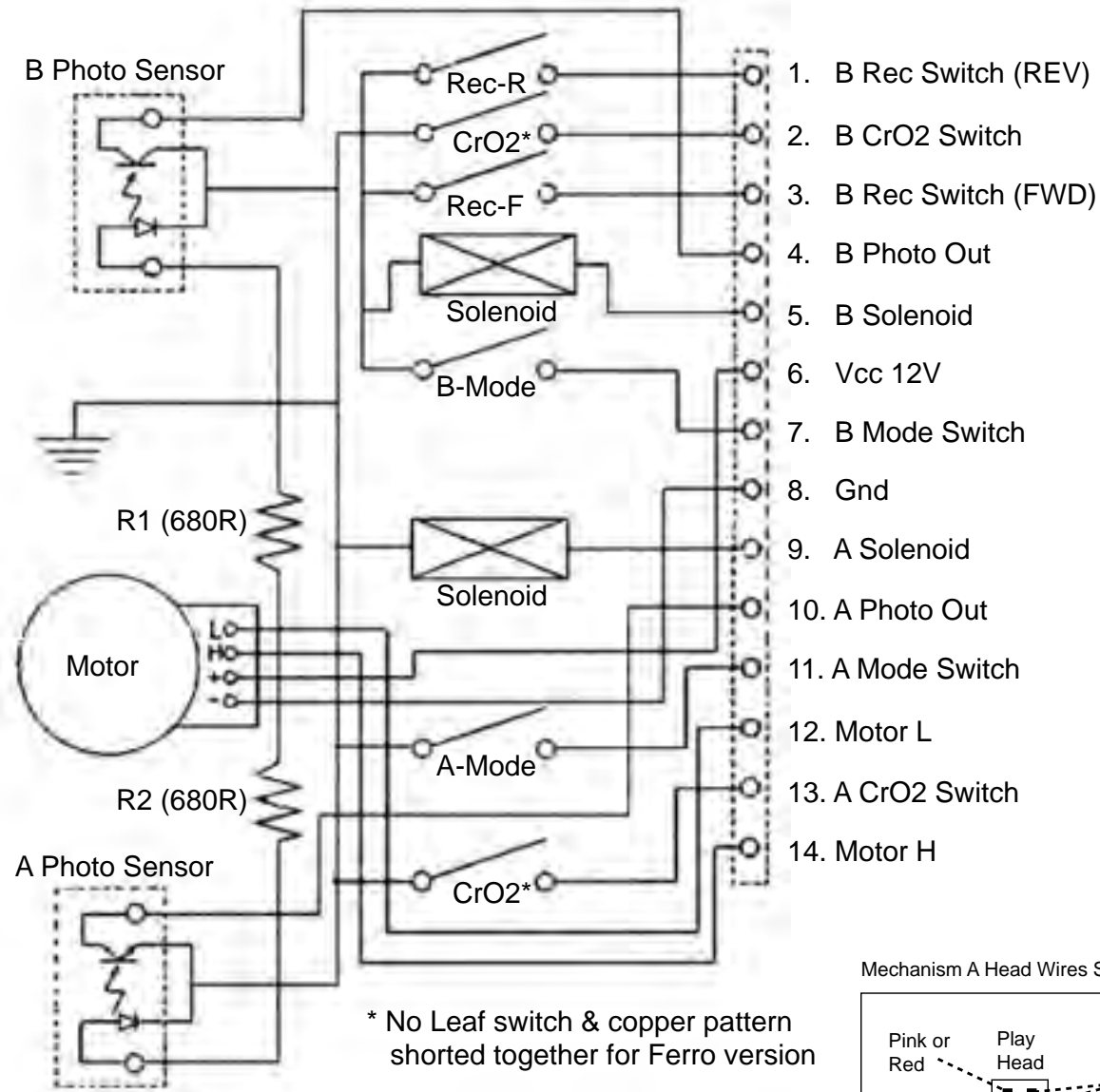

* No Leaf switch & copper pattern shorted together for Ferro version

Mechanism A Head Wires Soldering

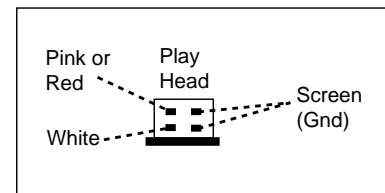

Mechanism B Head Wires Soldering (Non-Dolby version)

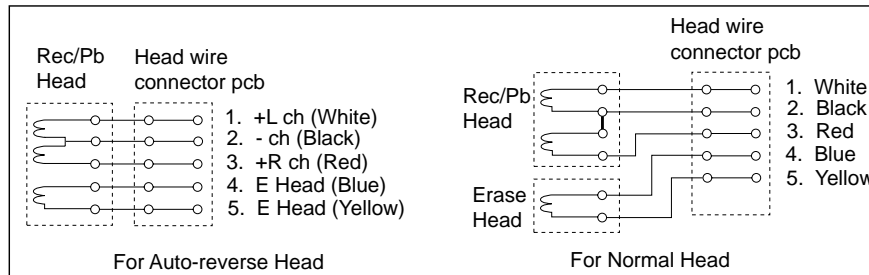

Mechanism B Head Wires Soldering (Dolby B NR version)

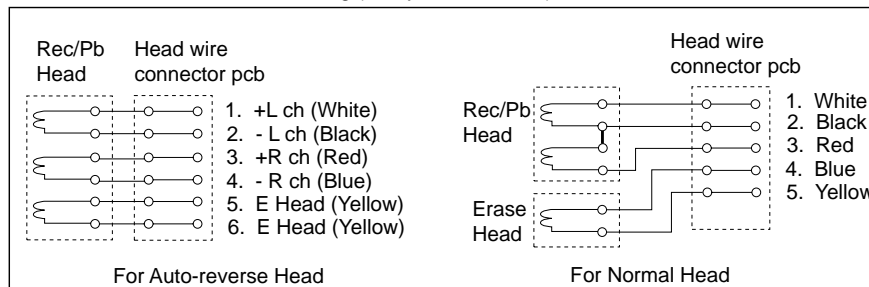

TAPE ADJUSTMENT & CHECK TABLE

	TEST CASSETTE	RECORDER MODE	MEASURE ON	READ ON	ADJUST	
					with	to
ADJUST MOTOR SPEED						
NORMAL SPEED	SBC420 3150Hz	PLAY B	1 or 2	frequency counter	3620	3150Hz +/- 0.5%
		PLAY A	LEFT RIGHT		check	3150Hz -0.8/+1.8%
CHECK WOW & FLUTTER						
DECK A & B	SBC420 3150Hz	PLAY	1 or 2	W&F-meter	check	<0.4 % DIN
ADJUST AZIMUTH						
DECK A & B	SBC420 10kHz	PLAY FWD	1 or 2	mV-meter	left hand screw	max. output level & left=right
		PLAY REV #	LEFT RIGHT		right hand screw	
CHECK PLAYBACK FREQUENCY RESPONSE						
DECK A & B	SBC420	PLAY	1 or 2	mV-meter	check	limits see fig.1
ADJUST BIAS CURRENT						
DECK B	SBC419A^	RECORD	5 or 6	mV-meter	3773	995mV
	SBC420		LEFT RIGHT		check	750mV +/- 1.5dB
CHECK OVERALL FREQUENCY RESPONSE AND DISTORTION						
Inject 3mV signals 100Hz, 250Hz, 1kHz, 10kHz, 12.5kHz via 3 or 4	SBC419A^ or SBC420	RECORD B				
	RECORDED CASSETTE	PLAY B	1 or 2	mV-meter	check	limits see fig. 2 *
Inject 1kHz 8.85mV via 3 or 4	SBC419A^ or SBC420	RECORD B				
	RECORDED CASSETTE	PLAY B	1 or 2	THD-meter	check	<3% *

SBC419A^ : 4822 397 30069
 SBC420 : 4822 397 30071

For Auto-reverse version only
 * If high frequencies are not within limits, decrease bias and re-measure.
 If distortion is too high, increase bias and re-measure
 ^ Not applicable for Ferro version

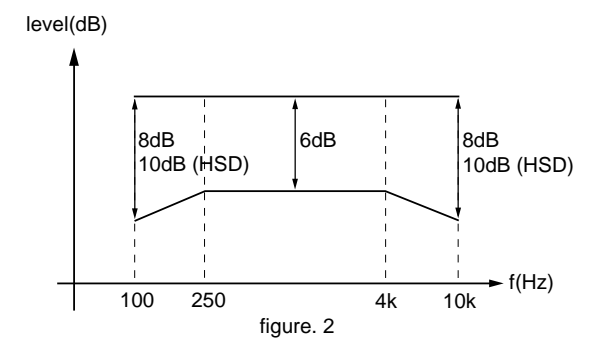
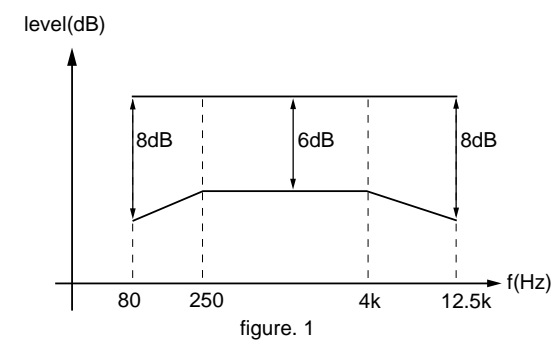

COMPONENT LAYOUT

1701 B2	2714 B2	2784 B1	3761 A1	6770 A1	6782 A2	9706 A1	9715 A1	9724 B2
1702 A2	2715 B2	2785 B1	3764 B2	6771 A1	6785 B2	9707 A2	9716 A2	9725 A2
1703 A2	2716 B2	3607 A1	3773 A1	6772 B1	6786 B2	9708 A2	9717 A2	9726 A2
1706 A1	2741 B1	3609 A1	3778 B1	6773 B1	7782 B1	9709 A2	9718 B2	9727 A2
1710 B1	2761 B2	3611 A1	5701 B1	6774 B1	7786 B2	9710 A1	9719 B1	9728 A2
1730 B2	2762 B2	3620 A1	5703 B1	6775 A1	9702 A1	9711 A1	9720 B1	9729 B1
1760 A2	2763 B2	3622 A1	6611 A2	6776 A1	9703 A1	9712 A1	9721 B1	9791 A2
1770 A2	2765 B2	3674 A2	6612 A2	6777 A1	9704 A2	9713 A1	9722 B1	9792 A2
2713 B2	2780 A1	3685 A1	6614 A1	6778 A1	9705 A2	9714 A1	9723 B2	9793 A1

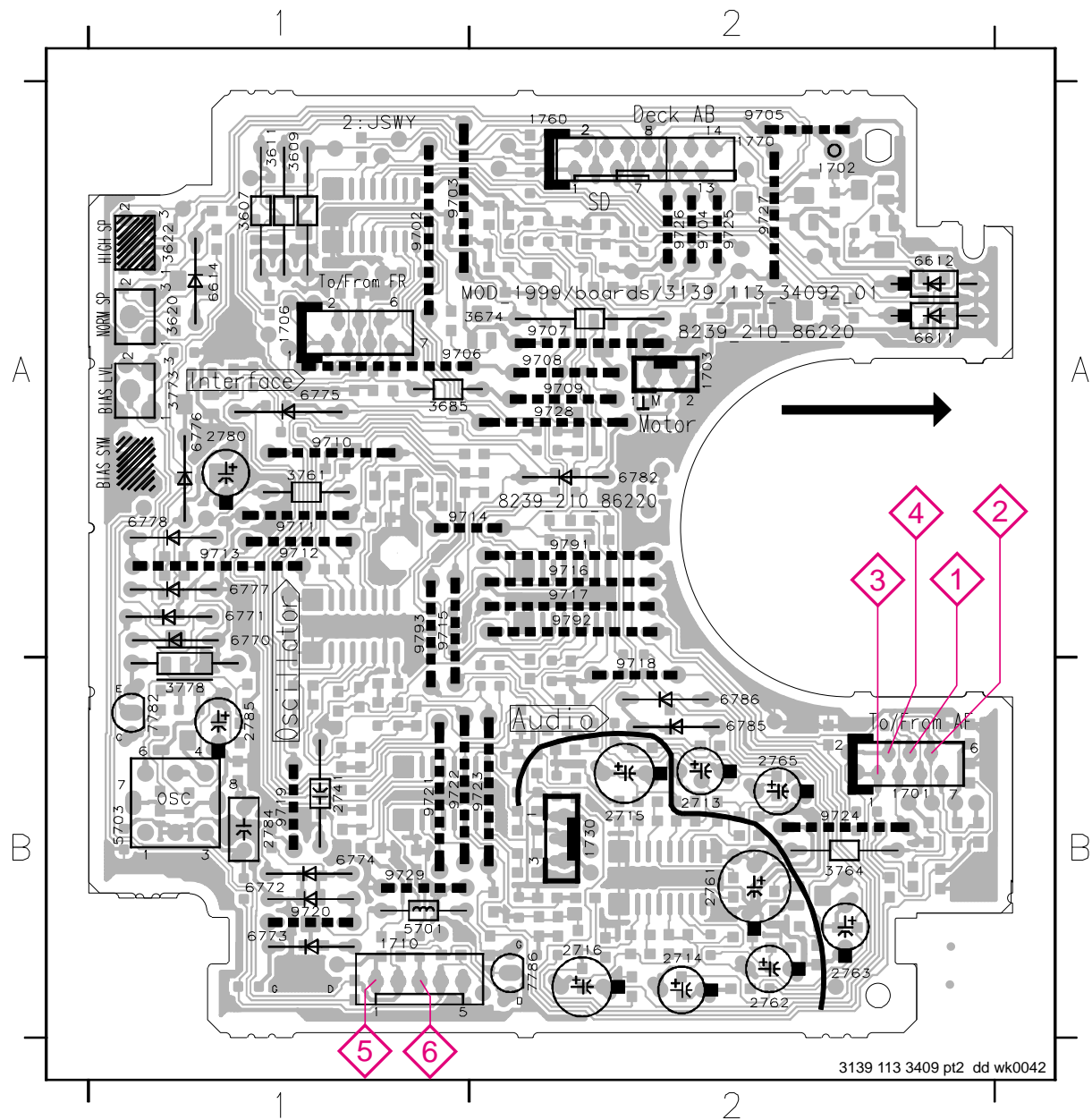

3139 113 3409 pt2 dd wk0042

CHIP LAYOUT

2621 A2	2724 B2	3602 A1	3688 A2	3725 A2	3757 A1	4701 A1	4727 B1	7612 A1
2622 A2	2725 A2	3603 A1	3689 A1	3726 B2	3758 A2	4702 A1	4728 B1	7613 A1
2623 A2	2726 B2	3604 A1	3701 B2	3727 B1	3759 A1	4703 A1	4729 B1	7614 A1
2624 A1	2727 B2	3605 A1	3702 B2	3728 B1	3760 B1	4704 A1	4730 B1	7616 A2
2625 A2	2728 B2	3606 A2	3703 B1	3729 A1	3762 A2	4705 A1	4731 B1	7618 A1
2626 A1	2729 A1	3608 A2	3704 B1	3730 B1	3763 B1	4706 A1	4732 B2	7619 A1
2627 A1	2730 B1	3610 A2	3705 B1	3731 A1	3765 B1	4707 A2	4733 B2	7620 A1
2701 B2	2733 B1	3612 A2	3706 B1	3732 B1	3766 B1	4708 A2	4734 B1	7622 A1
2702 B2	2734 B1	3613 A1	3707 B1	3733 B1	3767 B1	4709 A2	4735 B1	7623 A1
2703 B1	2735 B1	3614 A2	3708 B1	3734 B1	3768 B1	4710 A2	4736 B1	7624 A2
2704 B1	2737 B1	3616 A2	3709 B1	3735 B1	3769 A2	4711 A2	4737 B1	7710 B2
2705 B1	2738 B1	3618 A2	3710 B1	3736 B1	3770 B2	4712 A2	4738 B1	7720 B1
2706 B1	2742 A2	3619 A2	3711 B1	3741 B1	3771 B2	4713 A1	4739 B1	7730 A2
2707 B1	2743 B2	3623 A1	3712 B1	3742 B1	3772 A2	4714 A1	4740 B1	7740 A1
2708 B1	2744 B1	3624 A1	3713 B1	3743 B1	3774 A2	4715 A1	4741 B2	7780 A2
2709 B1	2745 B2	3625 A1	3714 B1	3744 B1	3775 B2	4716 A1	4742 B2	7781 B2
2710 B1	2746 B1	3626 A1	3715 B1	3745 B1	3776 B2	4717 A1	4744 A2	7783 A2
2711 B1	2747 B1	3628 A1	3716 B1	3746 B1	3777 B2	4718 A1	4745 A1	7784 B2
2712 B1	2760 A2	3630 A2	3717 A1	3748 B1	3779 B2	4719 A2	4746 A1	7787 B1
2717 A2	2769 B1	3672 A2	3718 B2	3749 A1	3780 B2	4720 A2	4747 A1	7791 A1
2718 B2	2770 B1	3676 A2	3719 A2	3751 A1	3781 B1	4721 A2	4748 B1	7792 A2
2719 A2	2781 B2	3678 A1	3720 B2	3752 A1	3784 B2	4722 A2	4785 A2	
2720 B2	2782 B2	3679 A1	3721 A2	3753 A1	3786 A2	4723 B1	4790 B2	
2721 A2	2786 B2	3680 A1	3722 B2	3754 A1	3787 A2	4724 B1	4794 B1	
2722 B2	2787 B2	3686 A2	3723 B2	3755 A1	3788 B2	4725 A1	4795 A1	
2723 A2	3601 A1	3687 A2	3724 B2	3756 A1	3789 A2	4726 B1	7610 A2	

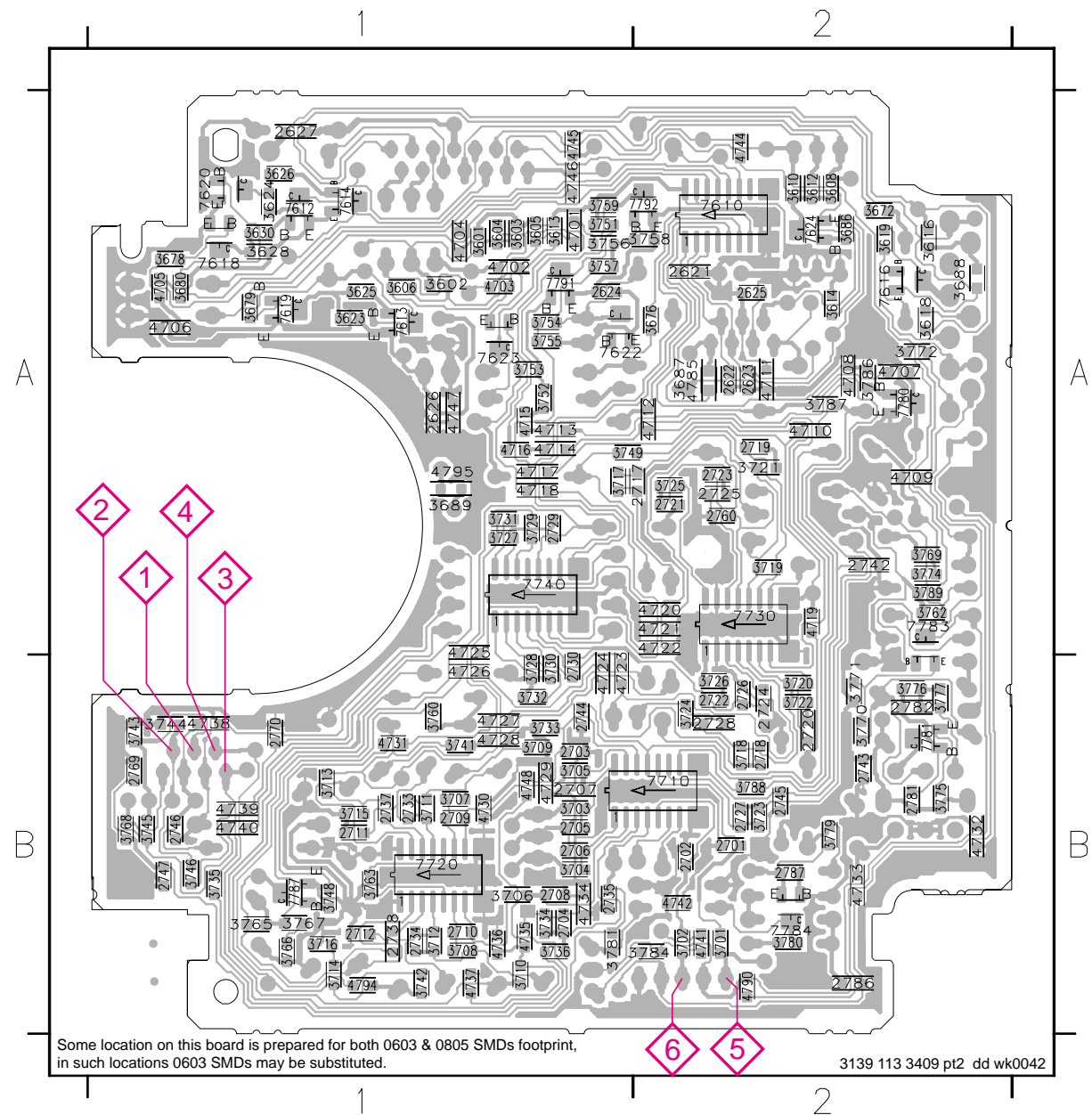

Some location on this board is prepared for both 0603 & 0805 SMDs footprint, in such locations 0603 SMDs may be substituted.

3139 113 3409 pt2 dd wk0042

ANALOG CIRCUIT

1701 F9	2705 A2	2712 B6	2719 C5	2726 D4	2735 B3	2745 F5	2765 B4	2785 F1	3705 A4	3712 B4	3719 C6	3726 D5	3733 A2	3744 F8	3753 F5	3760 A7	3767 A7	3774 E3	3781 D2	4794 C6	6774 D3	6786 B7	7782 E1	9791 A8
1710 C1	2706 A2	2713 A6	2720 D5	2727 A3	2737 A6	2746 F8	2769 F7	2786 D1	3706 B4	3713 A7	3720 E6	3727 A7	3734 B2	3745 F8	3754 E8	3761 E3	3768 E8	3775 F3	3784 D1	5701 D2	6775 C3	6787 A3	7783 E2	9792 B8
1730 A1	2707 A4	2714 B6	2721 C5	2728 E5	2738 B6	2747 E8	2770 F8	2787 D3	3707 A5	3714 B7	3721 C6	3728 B7	3735 A2	3746 E8	3755 E7	3762 E2	3769 E4	3776 F2	3786 F4	5703 F1	6776 F3	6788 A5	7784 D2	9793 A6
2701 B2	2708 B4	2715 A4	2722 D5	2729 A8	2741 D6	2760 E3	2780 F3	3701 B1	3708 B4	3715 A6	3722 D6	3729 A7	3736 B1	3748 C8	3756 D8	3763 A5	3770 F2	3777 F2	3787 C3	6770 E2	6777 E2	7730 D6	7786 C2	
2702 B2	2709 A5	2716 C4	2723 C5	2730 B8	2742 C3	2761 B5	2781 F2	3702 C2	3709 A4	3716 B6	3723 A3	3730 B7	3741 A6	3749 C7	3757 D8	3764 A5	3771 F2	3778 E1	3788 C3	6771 E2	6778 E4	7740 A8	7787 C8	
2703 A2	2710 B5	2717 C6	2724 D5	2733 A5	2743 F1	2762 B6	2782 F2	3703 A2	3710 C4	3717 C6	3724 D5	3731 A7	3742 C7	3751 E5	3758 D8	3765 B6	3772 F3	3779 D3	3789 F4	6772 D1	6782 C7	7780 F4	7791 F5	
2704 B2	2711 A6	2718 D6	2725 D4	2734 C4	2744 A4	2763 B6	2784 F1	3704 B1	3711 A5	3718 E6	3725 C5	3732 B7	3743 F8	3752 F4	3759 D7	3766 B7	3773 E3	3780 D2	4790 C3	6773 D1	6785 A7	7781 F3	7792 D8	

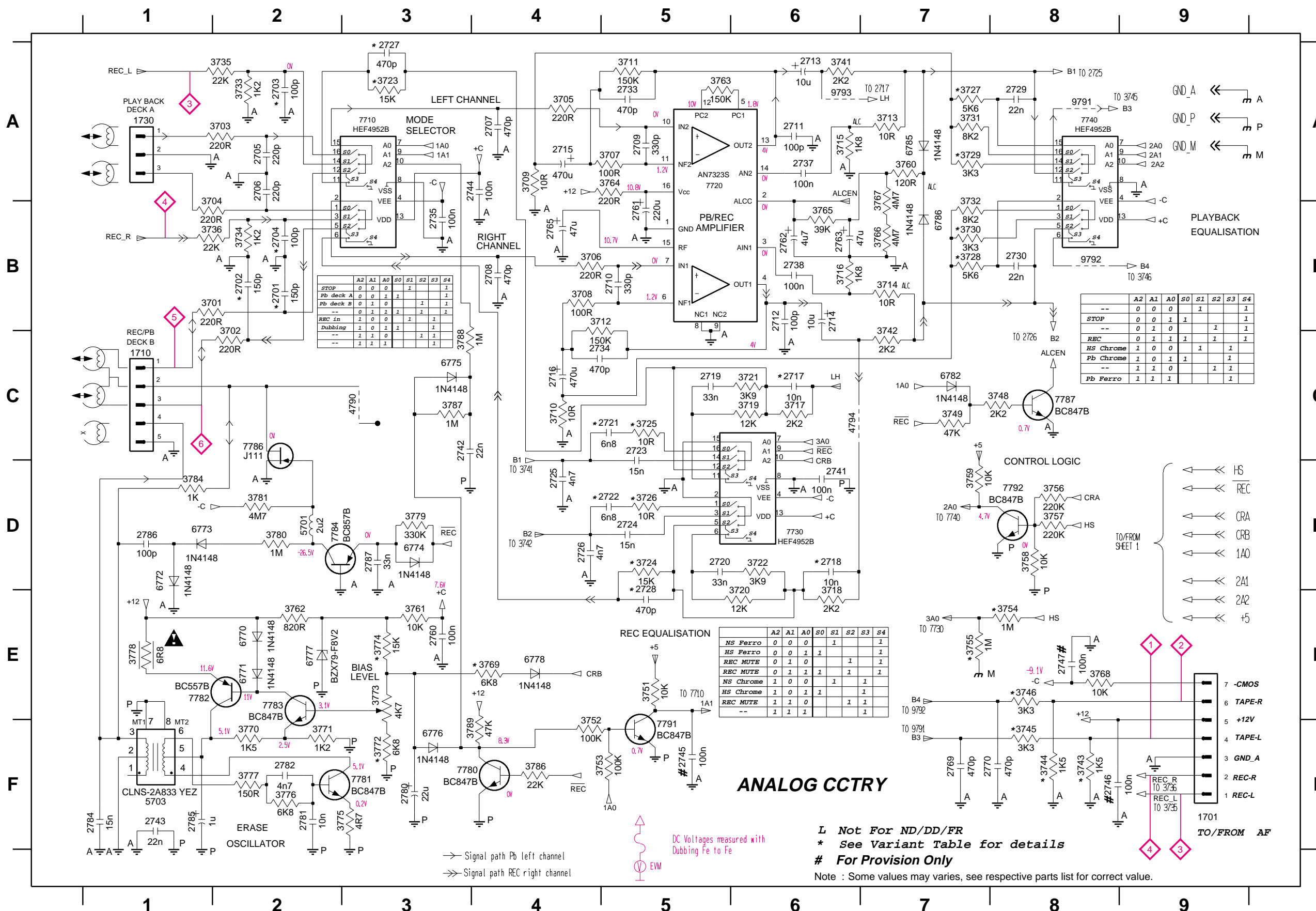

ANALOG CCTRY

L Not For ND/DD/FR
 * See Variant Table for details
 # For Provision Only

Note : Some values may varies, see respective parts list for correct value.

STOP	A2	A1	A0	S0	S1	S2	S3	S4
Pb deck A	0	0	1	1	1	1	1	1
Pb deck B	0	1	0	1	1	1	1	1
REC in	1	0	1	1	1	1	1	1
Dubbing	1	1	1	1	1	1	1	1
--	1	1	1	1	1	1	1	1

STOP	A2	A1	A0	S0	S1	S2	S3	S4
--	0	0	0	1	1	1	1	1
REC	0	1	1	1	1	1	1	1
HS Chrome	1	0	1	1	1	1	1	1
Pb Chrome	1	0	1	1	1	1	1	1
--	1	1	1	1	1	1	1	1
Pb Ferro	1	1	1	1	1	1	1	1

REC EQUALISATION	A2	A1	A0	S0	S1	S2	S3	S4
NS Ferro	0	0	0	1	1	1	1	1
HS Ferro	0	0	1	1	1	1	1	1
REC MUTE	0	1	0	1	1	1	1	1
REC MUTE	0	1	1	1	1	1	1	1
NS Chrome	1	0	0	1	1	1	1	1
HS Chrome	1	0	1	1	1	1	1	1
REC MUTE	1	1	0	1	1	1	1	1
--	1	1	1	1	1	1	1	1

- ← HS
- ← REC
- ← CRA
- ← CRB
- ← 1A0
- ← 2A1
- ← 2A2
- ← +5

→ Signal path Pb left channel
 ⇨ Signal path REC right channel



DC Voltages measured with Dubbing Fe to Fe

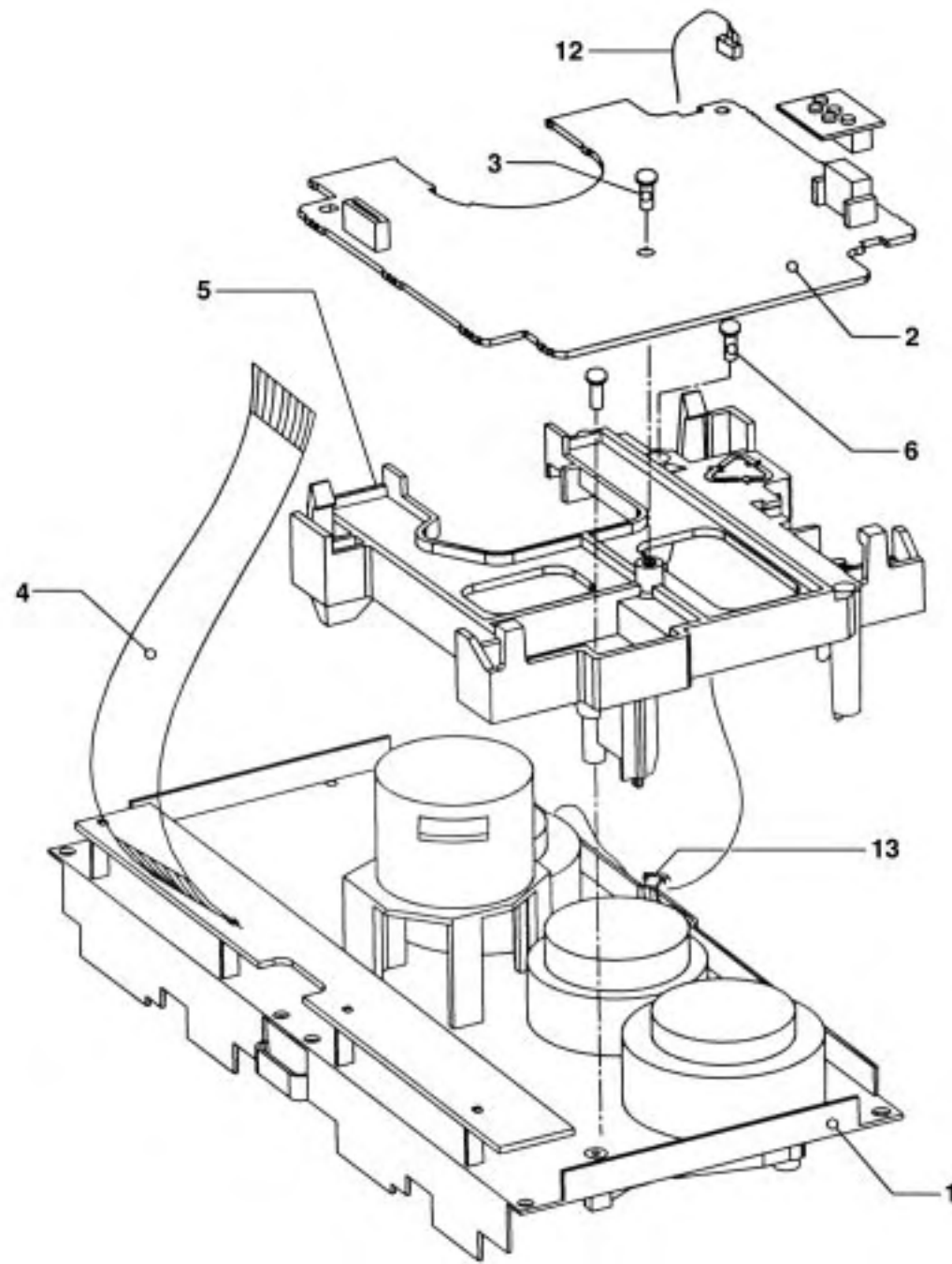

3139 118 77070 (Incl. ...77080) dd wk926

TAPE MODULE EXPLODED VIEW

- 1 3139 118 77130 Autoreverse Mech. CWE44FR01
- 1 3139 118 77140 Non-Autoreverse Mech. CWE44FF02 Chrome/Ferro
- 1 3139 118 77950 Non-Autoreverse Mech. CWE44FF05 Ferro
- 3 - Screw D3 x 10
- 6 - Screw M2 x 16
- 7 3139 110 34080 Flex Cable 14 pin 7,5 cm

Note: Only the parts mentioned in this list are normal service spare parts.

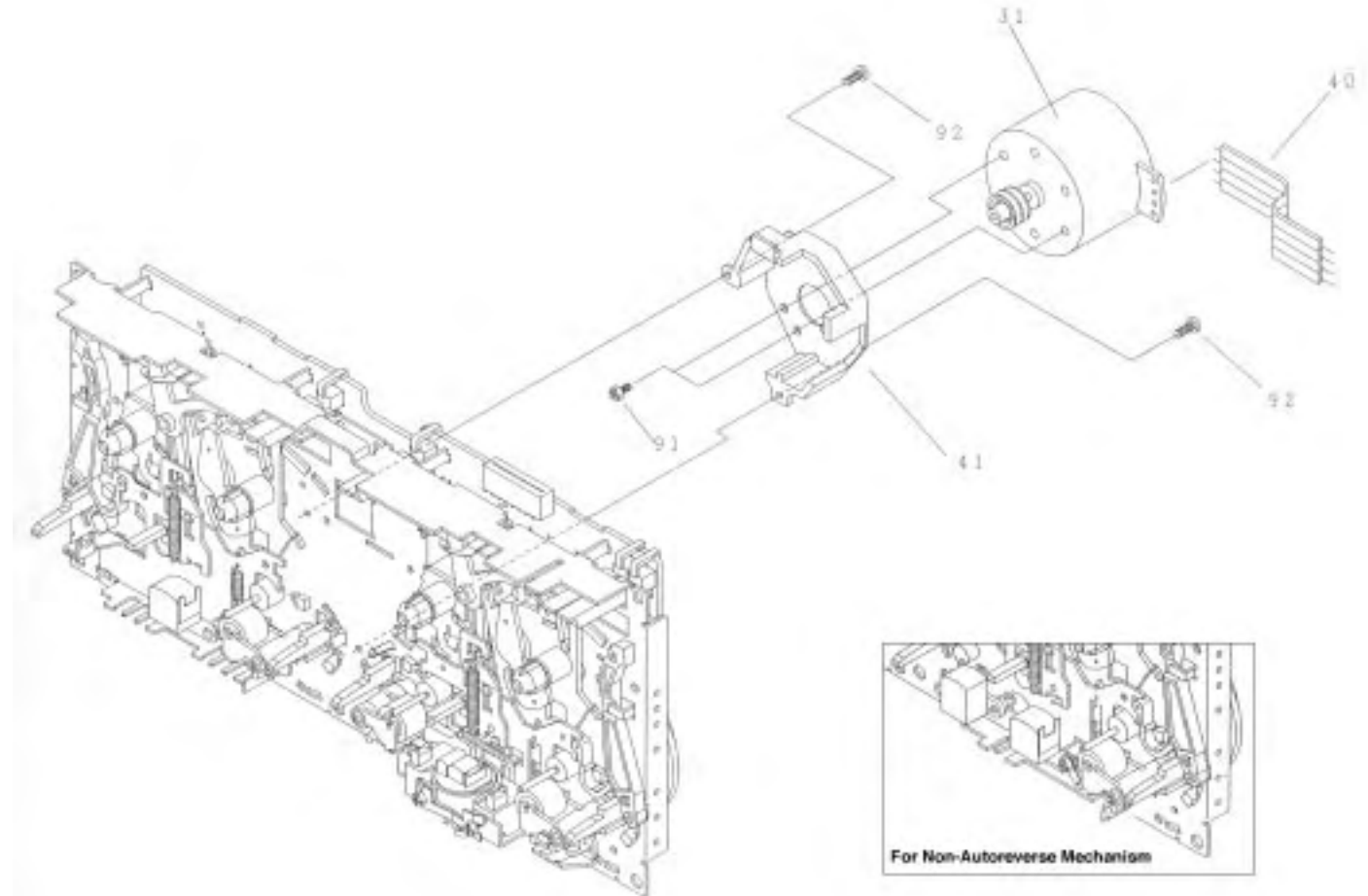

TAPE MECHANISM - MOTOR EXPLODED VIEW

- 31 4822 361 11055 Motor Assembly
- 91 - Screw M2,6 x 5
- 92 - Screw M2 x 5

Note: Only the parts mentioned in this list are normal service spare parts.

TAPE MECHANISM A - PLAY

MECHANICAL PARTS - PLAY MECHANISM

- 1 9965 000 02313 Play Head (Non-Autoreverse deck)
- 1 9965 000 02321 Play Head (Autoreverse deck)
- 12 4822 402 10972 Pinch Arm Assembly R
- 23 9965 000 02314 Coil Assembly

- 25 9965 000 06443 Cam Gear
- 32 4822 528 11209 Flywheel Assembly RV
- 42 9965 000 02315 Belt AF (Autoreverse deck)
- 42 9965 000 02718 Belt AF (Non-autoreverse deck)

- 69 4822 492 11761 Spring
- 102 4822 532 12931 Washer
- 103 4822 532 12932 Washer
- 104 4822 532 12933 Washer

Note: Only the parts mentioned in the list are normal service spare parts.

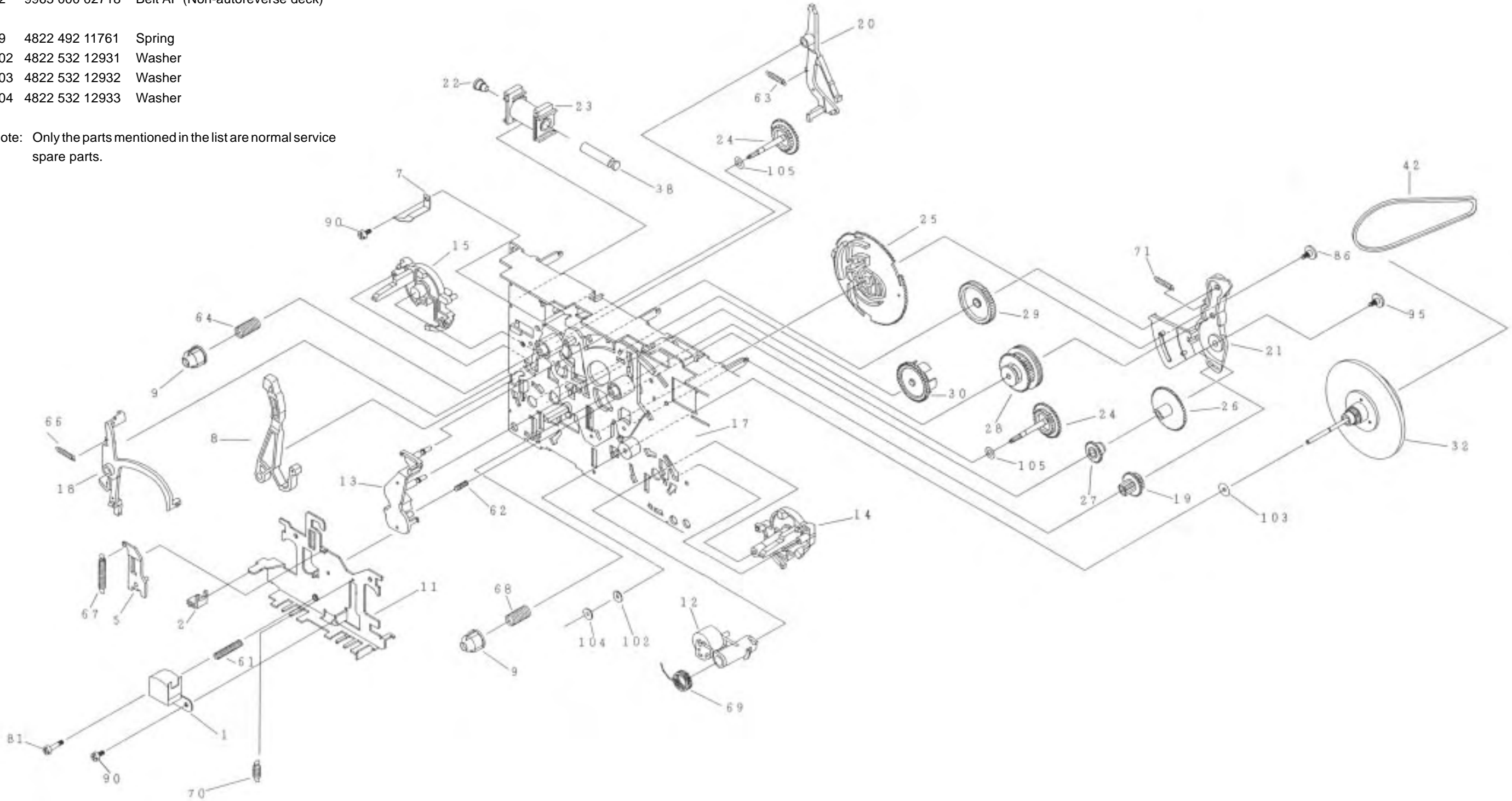

TAPE MECHANISM B - RECORD/PLAYBACK (Non-Autoreverse version)

MECHANICAL PARTS - REC/PB MECHANISM

1	9965 000 02313	Play Head
3	9965 000 02600	Head, Erase
12	4822 402 10972	Pinch Arm Assembly R
23	9965 000 02314	Coil Assembly
25	9965 000 06443	Cam Gear
32	4822 528 11209	Flywheel Assembly RV
44-2	9965 000 02317	Flex Socket 14 Pin
44-3	9965 000 02320	Photo Interrupter
44-4	4822 050 16801	680R 1% 0,4W
44-6	9965 000 02318	Leaf Switch
44-7	9965 000 02319	Mode Switch
59	9965 000 02719	Belt BF (Large)
69	4822 492 11761	Spring
102	4822 532 12931	Washer
103	4822 532 12932	Washer
104	4822 532 12933	Washer

Note: Only the parts mentioned in the list are normal service spare parts.

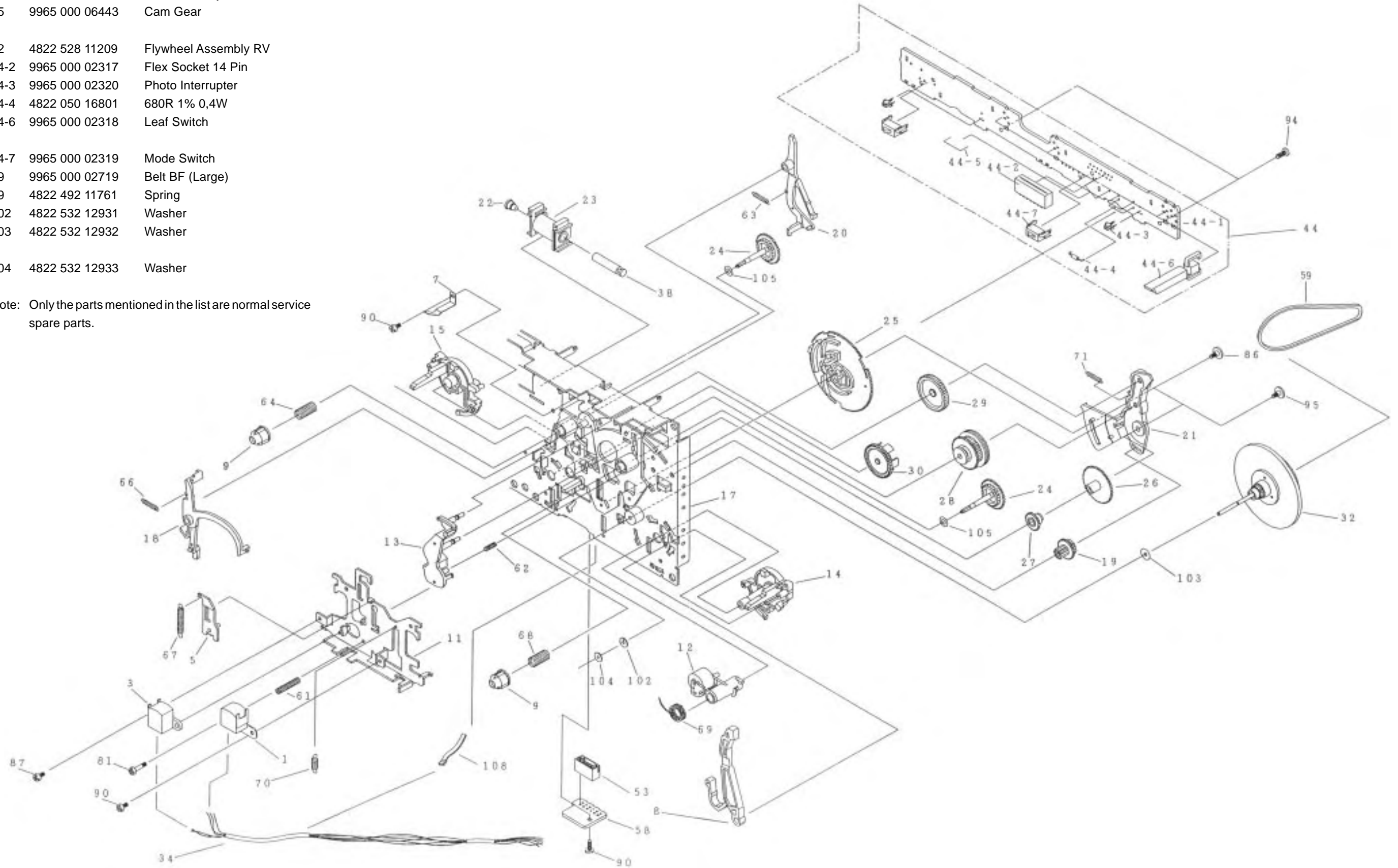

TAPE MECHANISM B - RECORD/PLAYBACK (Autoreverse version)

MECHANICAL PARTS - REC/PB MECHANISM

12	4822 402 10972	Pinch Arm Assembly R
23	9965 000 02314	Coil Assembly
25	9965 000 06443	Cam Gear
32	4822 528 11209	Flywheel Assembly RV
39	9965 000 02322	Belt AF
44-2	9965 000 02317	Flex Socket 14 Pin
44-3	9965 000 02320	Photo Interrupter
44-4	4822 050 16801	680R 1% 0,4W
44-6	9965 000 02318	Leaf Switch
44-7	9965 000 02319	Mode Switch
45	9965 000 02323	Rec/Pb Head Assembly
50	4822 402 10973	Pinch Arm Assembly L
54	9965 000 02324	Flywheel Assembly L
69	4822 492 11761	Spring
73	4822 492 11762	Spring
101	9965 000 02325	Washer
102	4822 532 12931	Washer
103	4822 532 12932	Washer
104	4822 532 12933	Washer
107	9965 000 02326	Washer
109	9965 000 02327	Washer

Note: Only the parts mentioned in the list are normal service spare parts.

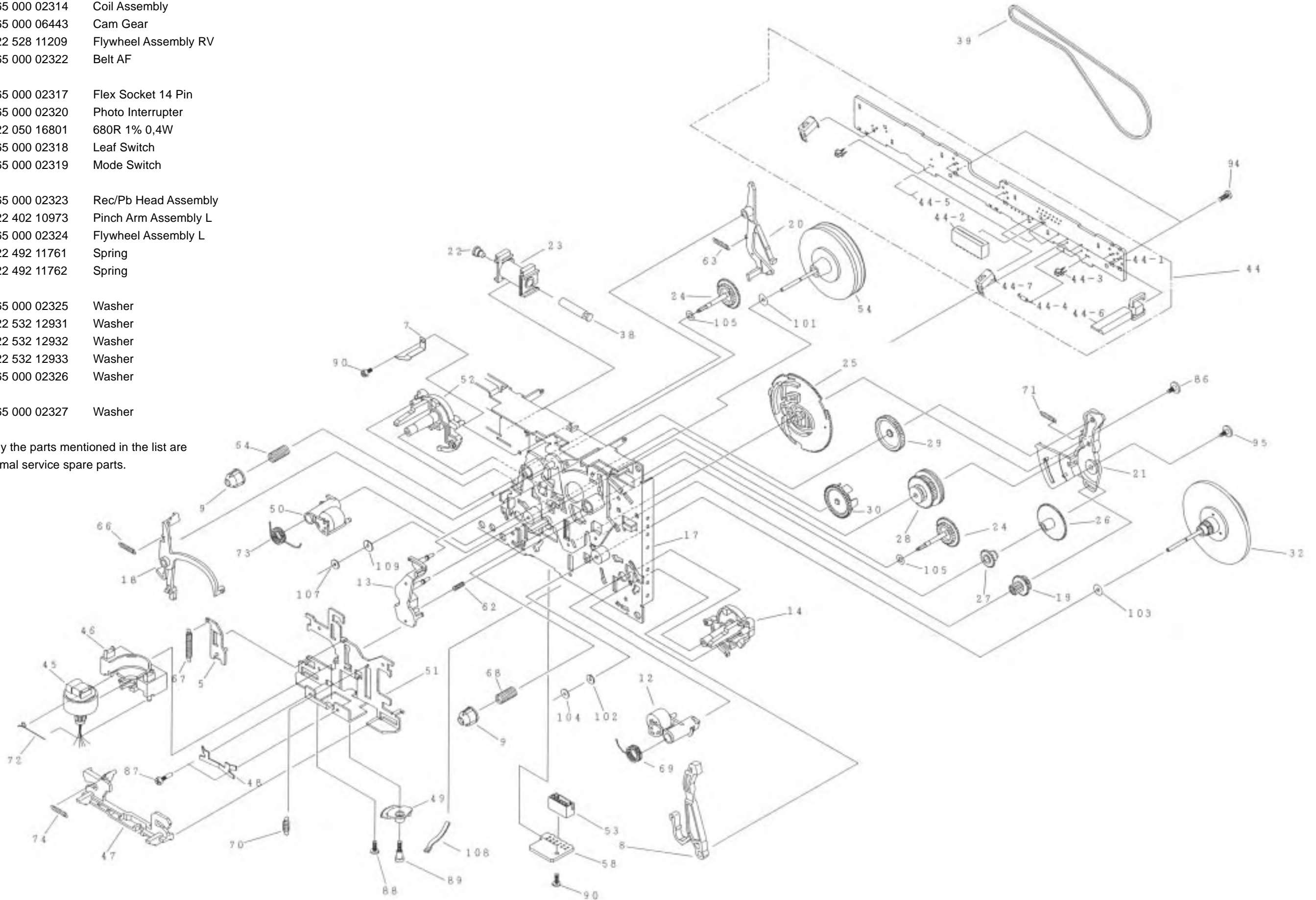

ELECTRICAL PARTS LIST - ETF7 NON-DOLBY BOARD

MISCELLANEOUS

1701	482226710953	Flex Socket 7pin Vert.
1706	482226710953	Flex Socket 7pin Vert.
1770	482226751255	Flex Socket 14pin Vert.

CAPACITORS

2621	532212231647	1nF 10% 63V
2622	532212234099	470pF 10% 63V
2623	532212234099	470pF 10% 63V
2624	482212614585	100nF 10% 50V only for Ferro
2625	482212614585	100nF 10% 50V
2701	532212233538	150pF 2% 63V Autoreverse
2701	482212233216	270pF 5% 63V Non-autoreverse
2702	532212233538	150pF 2% 63V Autoreverse
2702	482212233216	270pF 5% 63V Non-autoreverse
2703	532212232531	100pF 5% 50V Autoreverse
2703	482212233575	220pF 5% 63V Non-autoreverse
2704	532212232531	100pF 5% 50V Autoreverse
2704	482212233575	220pF 5% 63V Non-autoreverse
2705	482212233575	220pF 5% 63V
2706	482212233575	220pF 5% 63V
2707	532212234099	470pF 10% 63V
2708	532212234099	470pF 10% 63V
2709	532212231863	330pF 5% 63V
2710	532212231863	330pF 5% 63V
2711	532212232531	100pF 5% 50V
2712	532212232531	100pF 5% 50V
2713	482212440248	10μF 20% 63V
2714	482212440248	10μF 20% 63V
2715	482212480195	470μF 20% 10V
2716	482212480195	470μF 20% 10V
2717	482212233177	10nF 20% 50V Autoreverse
2717	482212613188	15nF 5% 63V Non-autoreverse
2718	482212233177	10nF 20% 50V Autoreverse
2718	482212613188	15nF 5% 63V Non-autoreverse
2719	482212612105	33nF 5% 50V
2720	482212612105	33nF 5% 50V
2721	532212231866	6,8nF 10% 63V not for Ferro
2722	532212231866	6,8nF 10% 63V not for Ferro
2723	482212613188	15nF 5% 63V
2724	482212613188	15nF 5% 63V
2725	532212610223	4,7nF 10% 63V
2726	532212610223	4,7nF 10% 63V
2727	532212234099	470pF 10% 63V Autoreverse
2727	532212231647	1nF 10% 63V Non-autoreverse
2728	532212234099	470pF 10% 63V Autoreverse
2728	532212231647	1nF 10% 63V Non-autoreverse
2729	532212232654	22nF 10% 63V
2730	532212232654	22nF 10% 63V
2733	532212234099	470pF 10% 63V
2734	532212234099	470pF 10% 63V
2735	482212614585	100nF 10% 50V
2737	482212614585	100nF 10% 50V

2738	482212614585	100nF 10% 50V
2741	482212611585	22nF +80/-20% 25V
2742	532212232654	22nF 10% 63V
2743	532212232654	22nF 10% 63V
2744	482212614585	100nF 10% 50V
2760	482212614585	100nF 10% 50V
2761	482212480144	220μF 20% 25V
2762	482212440769	4,7μF 20% 100V
2763	482212440433	47μF 20% 25V
2765	482212440433	47μF 20% 25V
2769	532212234099	470pF 10% 63V
2770	532212234099	470pF 10% 63V
2780	482212481151	22μF 20% 50V
2781	482212233177	10nF 20% 50V
2782	532212610223	4,7nF 10% 63V
2784	482212151305	15nF 10% 50V
2785	482212421913	1μF 20% 63V
2786	532212232531	100pF 5% 50V
2787	482212612105	33nF 5% 50V

RESISTORS

3601	482211711449	2k2 1% 0,1W
3602	482205120273	27k 5% 0,1W
3603	482211711449	2k2 1% 0,1W
3604	482211711148	56k 1% 0,1W
3605	482211711449	2k2 1% 0,1W
3606	482205120124	120k 5% 0,1W
3607	482211652256	2k2 5% 0,5W
3608	482205120273	27k 5% 0,1W
3609	482211652256	2k2 5% 0,5W
3610	482205120124	120k 5% 0,1W
3611	482211652256	2k2 5% 0,5W
3612	482211711148	56k 1% 0,1W
3613	482205120273	27k 5% 0,1W
3614	482205120273	27k 5% 0,1W
3616	482211710833	10k 1% 0,1W Autoreverse
3616	482205110102	1k 2% 0,25W Non-autoreverse
3618	482211711507	6k8 1% 0,1W Autoreverse
3620	482210011141	Trim. 10k 30% Autoreverse
3622	482210011141	Trim. 10k 30% Non-autoreverse
3623	482211710837	100k 1% 0,1W
3624	482211710837	100k 1% 0,1W
3625	482205110102	1k 2% 0,25W
3626	482205110102	1k 2% 0,25W
3628	482211710837	100k 1% 0,1W
3630	482205120471	470R 5% 0,1W
3672	482205120472	4k7 5% 0,1W Autoreverse
3674	482211652283	4k7 5% 0,5W
3676	482211710834	47k 1% 0,1W Autoreverse
3678	482211710834	47k 1% 0,1W
3679	482211710834	47k 1% 0,1W
3680	482211710834	47k 1% 0,1W

ELECTRICAL PARTS LIST - ETF7 NON-DOLBY BOARD

3685	482211652234	100k 5% 0,5W
3686	482211710837	100k 1% 0,1W
3687	482211711503	220R 1% 0,1W not for Ferro
3688	482211710361	680R 1% 0,1W Autoreverse
3701	482211711503	220R 1% 0,1W
3702	482211711503	220R 1% 0,1W
3703	482211711503	220R 1% 0,1W
3704	482211711503	220R 1% 0,1W
3705	482211711503	220R 1% 0,1W
3706	482211711503	220R 1% 0,1W
3707	482205120101	100R 5% 0,1W
3708	482205120101	100R 5% 0,1W
3709	482205120109	10R 5% 0,1W
3710	482205120109	10R 5% 0,1W
3711	482205120154	150k 5% 0,1W
3712	482205120154	150k 5% 0,1W
3713	482205120109	10R 5% 0,1W
3714	482205120109	10R 5% 0,1W
3715	482205120182	1k8 5% 0,1W
3716	482205120182	1k8 5% 0,1W
3717	482211711449	2k2 1% 0,1W
3718	482211711449	2k2 1% 0,1W
3719	482211711383	12k 1% 0,1W
3720	482211711383	12k 1% 0,1W
3721	482205120392	3k9 5% 0,1W
3722	482205120392	3k9 5% 0,1W
3723	482211683933	15k 1% 0,1W Autoreverse
3723	482211710965	18k 1% 0,1W Non-autoreverse
3724	482211683933	15k 1% 0,1W Autoreverse
3724	482211710965	18k 1% 0,1W Non-autoreverse
3725	482205120109	10R 5% 0,1W not for Ferro
3726	482205120109	10R 5% 0,1W not for Ferro
3727	482205120562	5k6 5% 0,1W Autoreverse
3727	482211711507	6k8 1% 0,1W Non-autoreverse
3728	482205120562	5k6 5% 0,1W Autoreverse
3728	482211711507	6k8 1% 0,1W Non-autoreverse
3729	482205120332	3k3 5% 0,1W Autoreverse
3729	482205120472	4k7 5% 0,1W Non-autoreverse
3730	482205120332	3k3 5% 0,1W Autoreverse
3730	482205120472	4k7 5% 0,1W Non-autoreverse
3731	482205120822	8k2 5% 0,1W
3732	482205120822	8k2 5% 0,1W
3733	482205120122	1k2 5% 0,1W
3734	482205120122	1k2 5% 0,1W
3735	482205120223	22k 5% 0,1W
3736	482205120223	22k 5% 0,1W
3741	482211711449	2k2 1% 0,1W
3742	482211711449	2k2 1% 0,1W
3743	482211711139	1k5 1% 0,1W Autoreverse
3743	482211711449	2k2 1% 0,1W Non-autoreverse
3744	482211711139	1k5 1% 0,1W Autoreverse
3744	482211711449	2k2 1% 0,1W Non-autoreverse

3745	482205120332	3k3 5% 0,1W Autoreverse
3745	482205120562	5k6 5% 0,1W Non-autoreverse
3746	482205120332	3k3 5% 0,1W Autoreverse
3746	482205120562	5k6 5% 0,1W Non-autoreverse
3748	482211711449	2k2 1% 0,1W
3749	482211710834	47k 1% 0,1W
3751	482211710833	10k 1% 0,1W
3752	482211710837	100k 1% 0,1W
3753	482211710837	100k 1% 0,1W
3754	482205120105	1M 5% 0,1W Autoreverse
3754	482205120479	47R 5% 0,1W Non-autoreverse
3755	482205120105	1M 5% 0,1W Autoreverse
3755	482205120479	47R 5% 0,1W Non-autoreverse
3756	482211713579	220k 1% 0,1W
3757	482211713579	220k 1% 0,1W
3758	482211710833	10k 1% 0,1W
3759	482211710833	10k 1% 0,1W
3760	482205120121	120R 5% 0,1W
3761	482205021003	10k 1% 0,6W
3762	482211711454	820R 1% 0,1W
3763	482205120154	150k 5% 0,1W
3764	482211683872	220R 5% 0,5W
3765	482205120393	39k 5% 0,1W
3766	482205120475	4M7 5% 0,1W
3767	482205120475	4M7 5% 0,1W
3768	482211710833	10k 1% 0,1W
3769	482211711383	12k 1% 0,1W Autoreverse
3769	482205120822	8k2 5% 0,1W Non-autoreverse
3770	482211711139	1k5 1% 0,1W
3771	482205120122	1k2 5% 0,1W
3772	482211711507	6k8 1% 0,1W Autoreverse
3772	482205120562	5k6 5% 0,1W Non-autoreverse
3773	482210012227	Trimmer 4k7 30% 0,1W
3774	482211683933	15k 1% 0,1W Autoreverse
3774	482205120822	8k2 5% 0,1W Non-autoreverse
3775	482205120478	4R7 5% 0,1W
3776	482211711507	6k8 1% 0,1W
3777	482211710353	150R 1% 0,1W
3778	482205210688	△ 6R8 5% 0,33W
3779	482205120334	330k 5% 0,1W
3780	482205120105	1M 5% 0,1W
3781	482205120475	4M7 5% 0,1W
3784	482205110102	1k 2% 0,25W
3786	482205120223	22k 5% 0,1W
3787	482205120105	1M 5% 0,1W
3788	482205120105	1M 5% 0,1W
3789	482211710834	47k 1% 0,1W
4701	482205120008	0R Jumper 0805
4702	482205120008	0R Jumper 0805
4703	482205120008	0R Jumper 0805
4704	482205120008	0R Jumper 0805
4705	482205120008	0R Jumper 0805

ELECTRICAL PARTS LIST - ETF7 NON-DOLBY BOARD**RESISTORS**

4706	482205120008	OR Jumper 0805	6612	482213031878	1N4003G	
4707	482205120008	OR Jumper 0805	6614	482213030621	1N4148	Autoreverse
4708	482205120008	OR Jumper 0805	6770	482213030621	1N4148	
4709	482205120008	OR Jumper 0805	6771	482213030621	1N4148	
4710	482205120008	OR Jumper 0805	6772	482213030621	1N4148	
4711	482205120008	OR Jumper 0805	6773	482213030621	1N4148	
4712	482205120008	OR Jumper 0805	6774	482213030621	1N4148	
4713	482205120008	OR Jumper 0805	6775	482213030621	1N4148	
4714	482205120008	OR Jumper 0805	6776	482213030621	1N4148	
4715	482205120008	OR Jumper 0805	6777	482213034382	BZX79-F8V2	
4716	482205120008	OR Jumper 0805	6778	482213030621	1N4148	
4717	482205120008	OR Jumper 0805	6782	482213030621	1N4148	
4718	482205120008	OR Jumper 0805	6785	482213030621	1N4148	
4719	482205120008	OR Jumper 0805	6786	482213030621	1N4148	
4720	482205120008	OR Jumper 0805				
4721	482205120008	OR Jumper 0805				
4722	482205120008	OR Jumper 0805				
4723	482205120008	OR Jumper 0805				
4724	482205120008	OR Jumper 0805				
4725	482205120008	OR Jumper 0805				
4726	482205120008	OR Jumper 0805				
4727	482205120008	OR Jumper 0805				
4728	482205120008	OR Jumper 0805				
4729	482205120008	OR Jumper 0805				
4730	482205120008	OR Jumper 0805				
4731	482205120008	OR Jumper 0805				
4732	482205120008	OR Jumper 0805				
4733	482205120008	OR Jumper 0805				
4734	482205120008	OR Jumper 0805				
4735	482205120008	OR Jumper 0805				
4736	482205120008	OR Jumper 0805				
4737	482205120008	OR Jumper 0805				
4738	482205120008	OR Jumper 0805				
4739	482205120008	OR Jumper 0805				
4740	482205120008	OR Jumper 0805				
4741	482205120008	OR Jumper 0805				
4742	482205120008	OR Jumper 0805				
4744	482205120008	OR Jumper 0805				
4745	482205120008	OR Jumper 0805				
4746	482205120008	OR Jumper 0805				
4748	482205120008	OR Jumper 0805				
4785	482205120008	OR Jumper 0805 only for Ferro				
4790	482205120008	OR Jumper 0805				
4794	482205120008	OR Jumper 0805				
4795	482205120008	OR Jumper 0805				

TRANSISTORS & INTEGRATED CIRCUITS

7610	532220911306	HEF4094BT			
7612	482213011201	PMBT2907			
7613	482213011201	PMBT2907			
7614	482213011201	PMBT2907			
7616	482213060373	BC857B			Autoreverse
7618	482213060511	BC847B			
7619	482213060511	BC847B			
7620	482213060511	BC847B			
7622	482213060511	BC847B			Autoreverse
7623	482213060511	BC847B			
7624	482213060511	BC847B			
7710	482220932919	HEF4952BT			
7720	932214000668	AN7323S			
7730	482220932919	HEF4952BT			
7740	482220932919	HEF4952BT			
7780	482213060511	BC847B			
7781	482213042804	BC817-25			
7782	482213044568	BC557B			
7783	482213060511	BC847B			
7784	482213060373	BC857B			
7786	482213063494	J111			
7787	482213060511	BC847B			
7791	482213060511	BC847B			
7792	482213060511	BC847B			

Note: Only the parts mentioned in this list are normal service spare parts.

COILS & FILTERS

5701	482215711477	Coil 2,2μH 5%
5703	482215620946	Osc Coil 100kHz

DIODES

6611	482213031878	1N4003G
------	--------------	---------



3CDC-LC-MP3CD2002

(3 Disc Carousel Changer+MP3 Board) Layout stage .2

TABLE OF CONTENTS

Service Hints	10-2
Wiring Diagram	10-4
Blockdiagram	10-5

CD PART

Component Layout Main Board	10-6
Circuit Diagram	10-7

MP3 PART

Component Layout Main Board	10-8
Circuit Diagram	10-9

Exploded View	10-10
Partslist	10-12



Service hints

CAUTION

CHARGED CAPACITORS ON THE SERVO BOARD MAY DAMAGE THE CD DRIVE ELECTRONICS WHEN CONNECTING A NEW CD MECHANISM. THAT'S WHY, BESIDES THE SAFETY MEASURES LIKE

- **SWITCH OFF POWER SUPPLY**
- **ESD PROTECTION**

ADDITIONAL ACTIONS MUST BE TAKEN BY THE REPAIR TECHNICIAN.

The following steps have to be done when replacing the CD mechanism:

1. Disconnect flexfoil cable from the old CD drive
2. Put a paperclip on the flexfoil to short-circuit the contacts (fig.1)
3. Remove the old CD drive
4. Remove paperclip from the flexfoil and connect it to the new drive
5. Position the new CD drive in its studs
6. Remove solder joint from the Laserunit

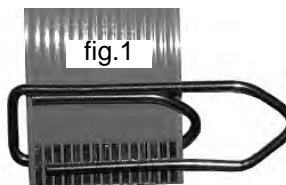

Attention: The laser diode of this CD drive is protected against ESD by a solder joint which shortcircuits the laserdiode to ground.

For proper functionality of the CD drive this solder joint must be removed **after** connection the drive to the set.

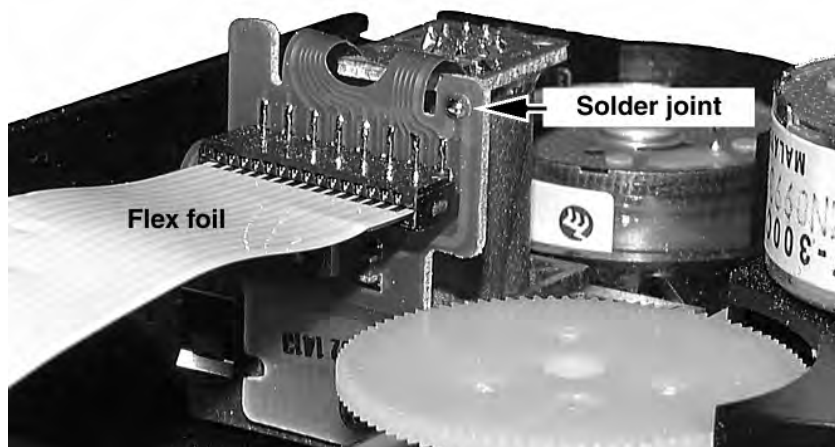

Emergency open

In case of a Supply fault, the tray can be opened manually.

1. Remove the top cover of the set to get access to the Changer Module.
2. Turn gearwheel clockwise (as shown in picture below).

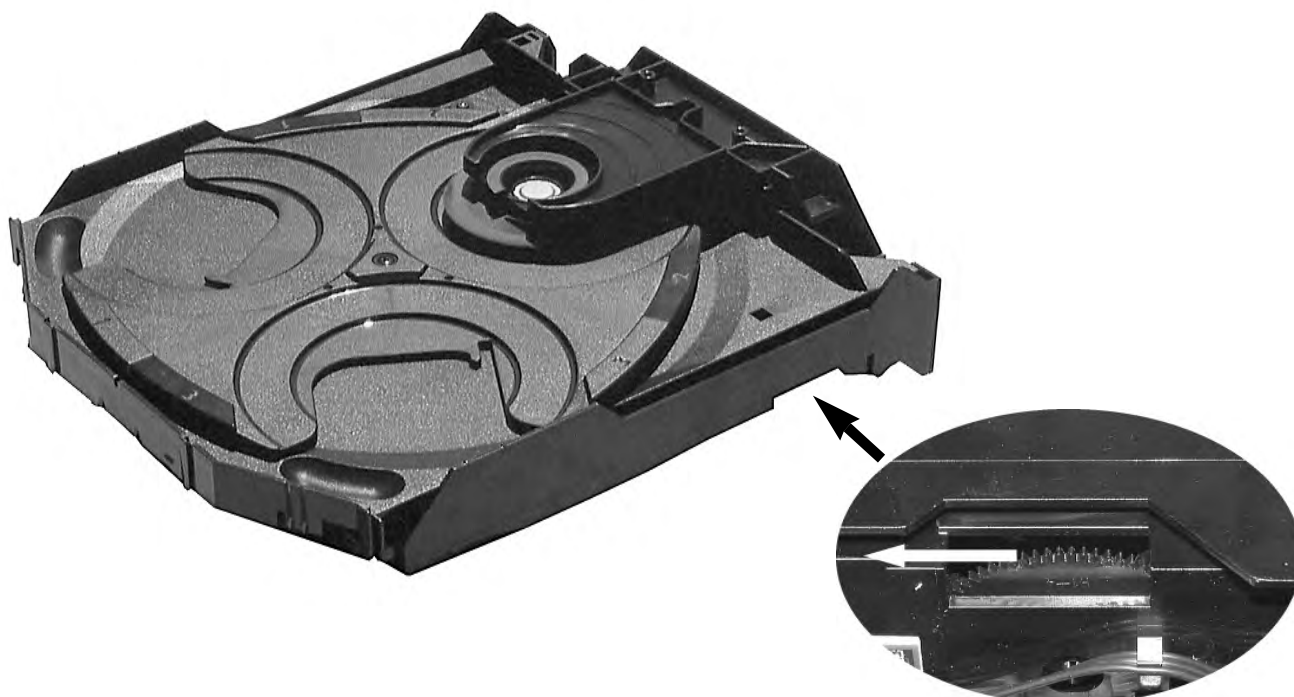

Service hints

Dismantling of Tray

1. Open the tray.
2. Release 2x catch as shown in fig. 2 and Detail A
3. Pull tray out.

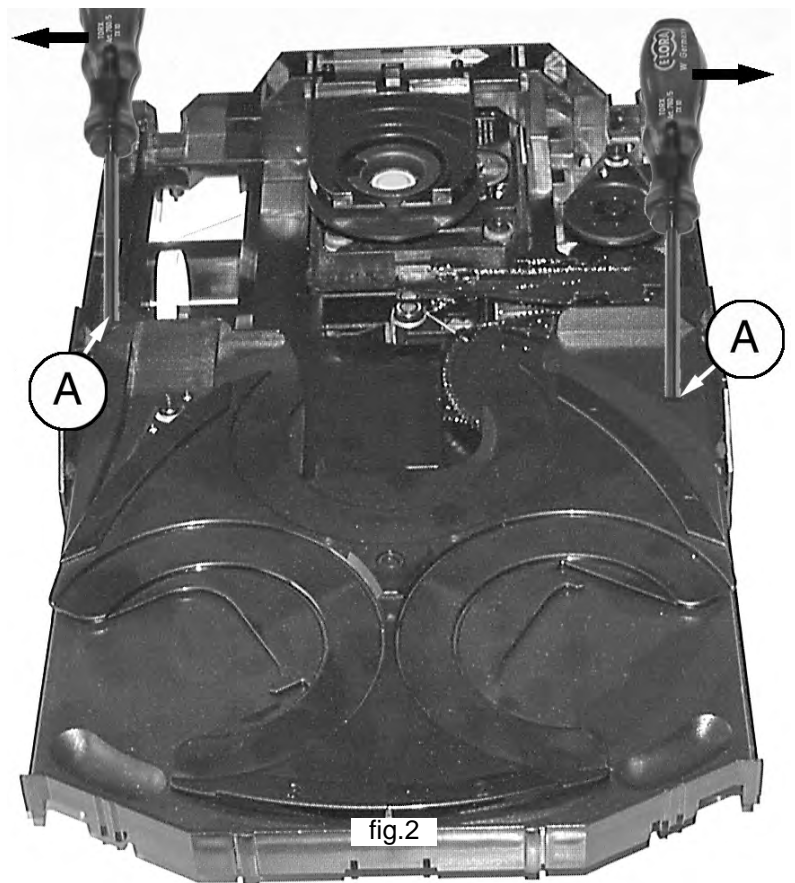
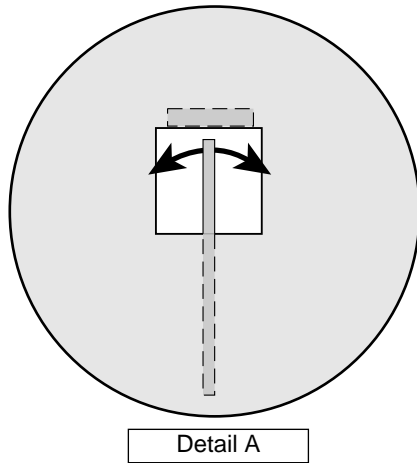

Assembling of Tray

1. Turn Cam (pos. 48) clockwise to end position.
2. If necessary - move Guiding (pos. 49) to the right end position.
3. Insert the Tray.

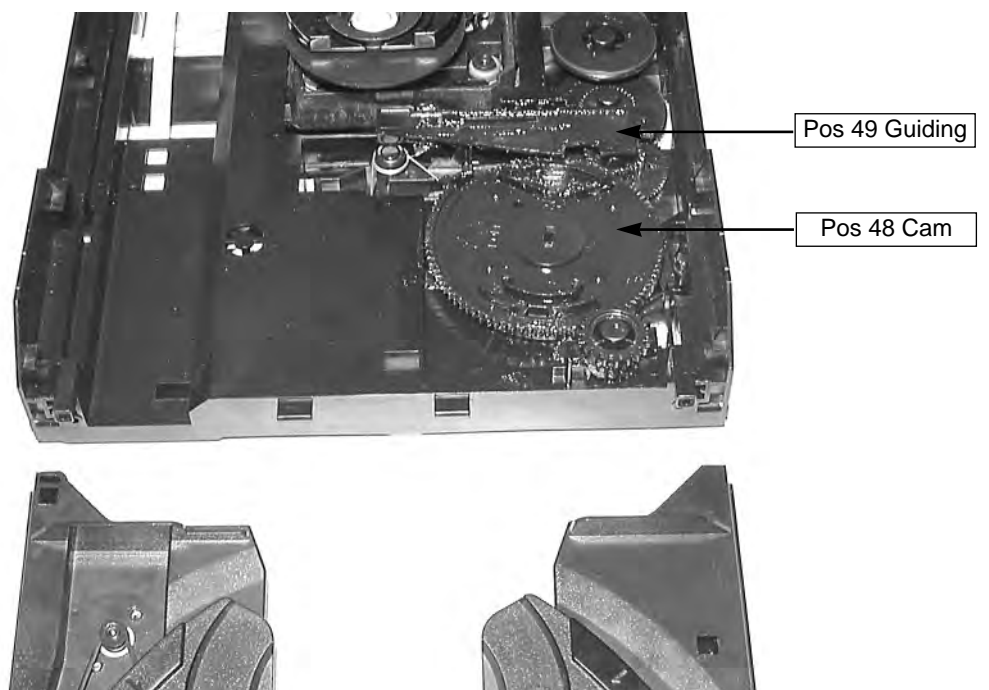

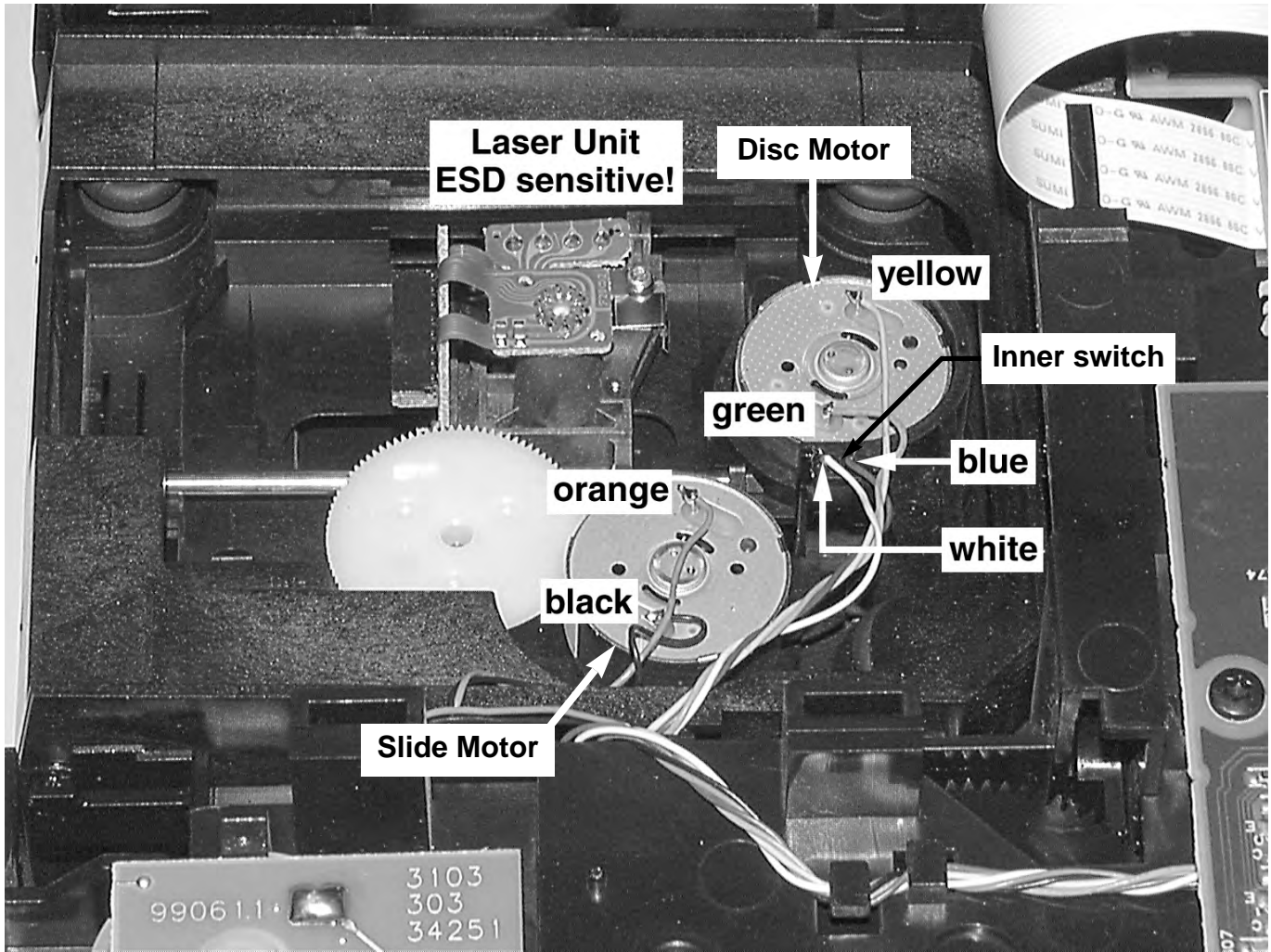

Service Position

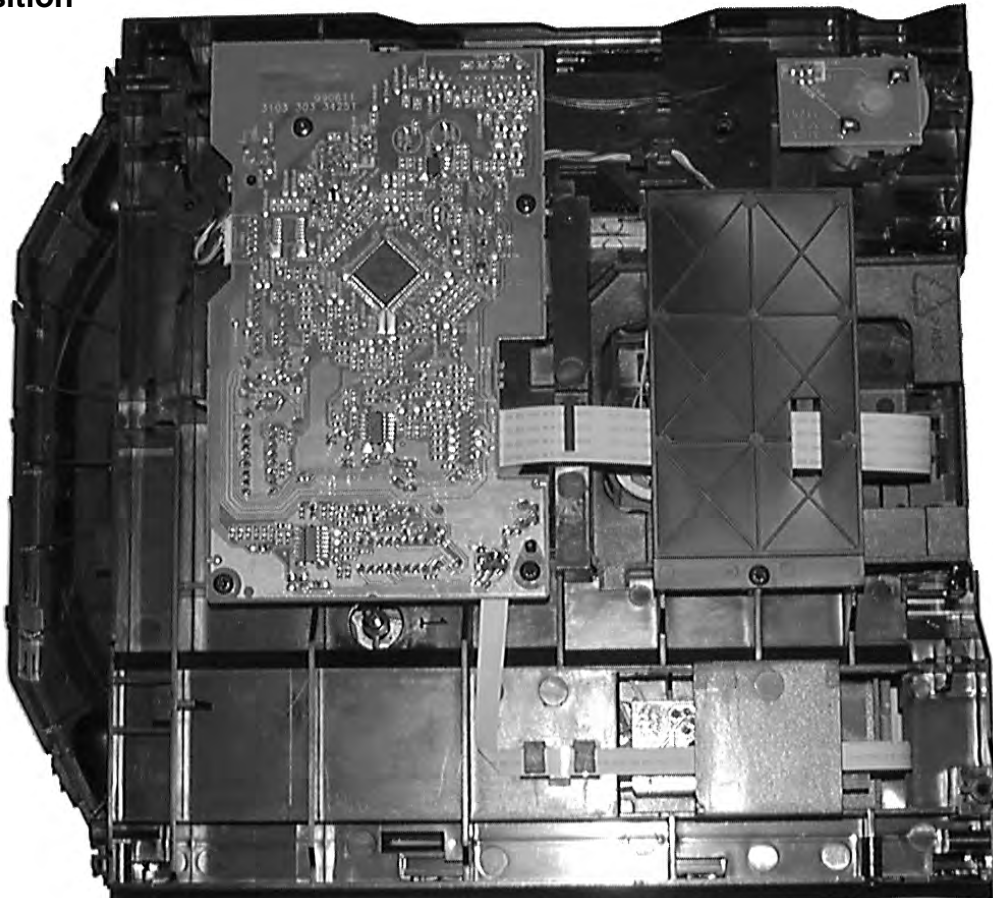

BLOCK DIAGRAM 3CDC-LC MP3 Version

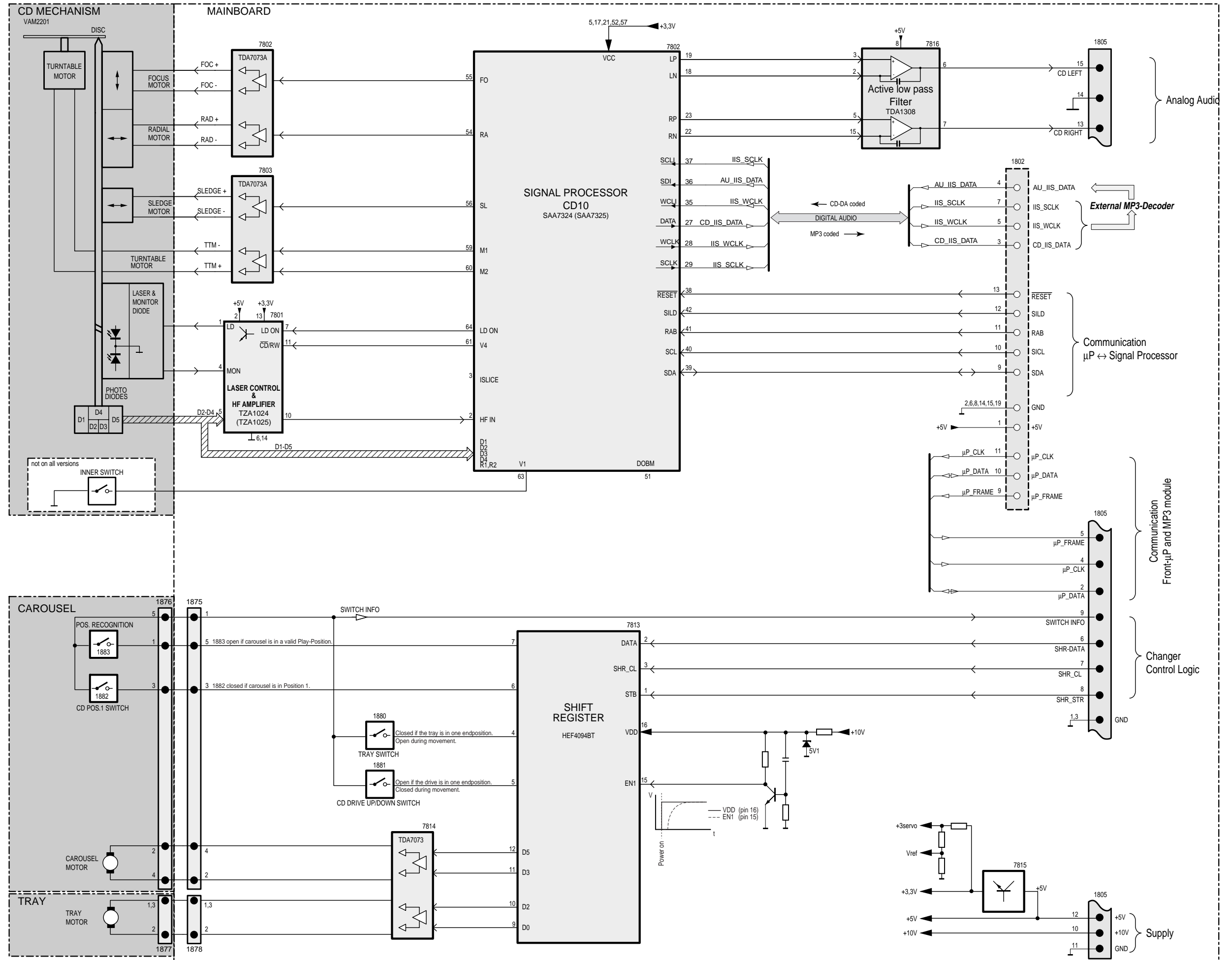

Mapping

3CDC-LC-MP3CD2002 Copperside view

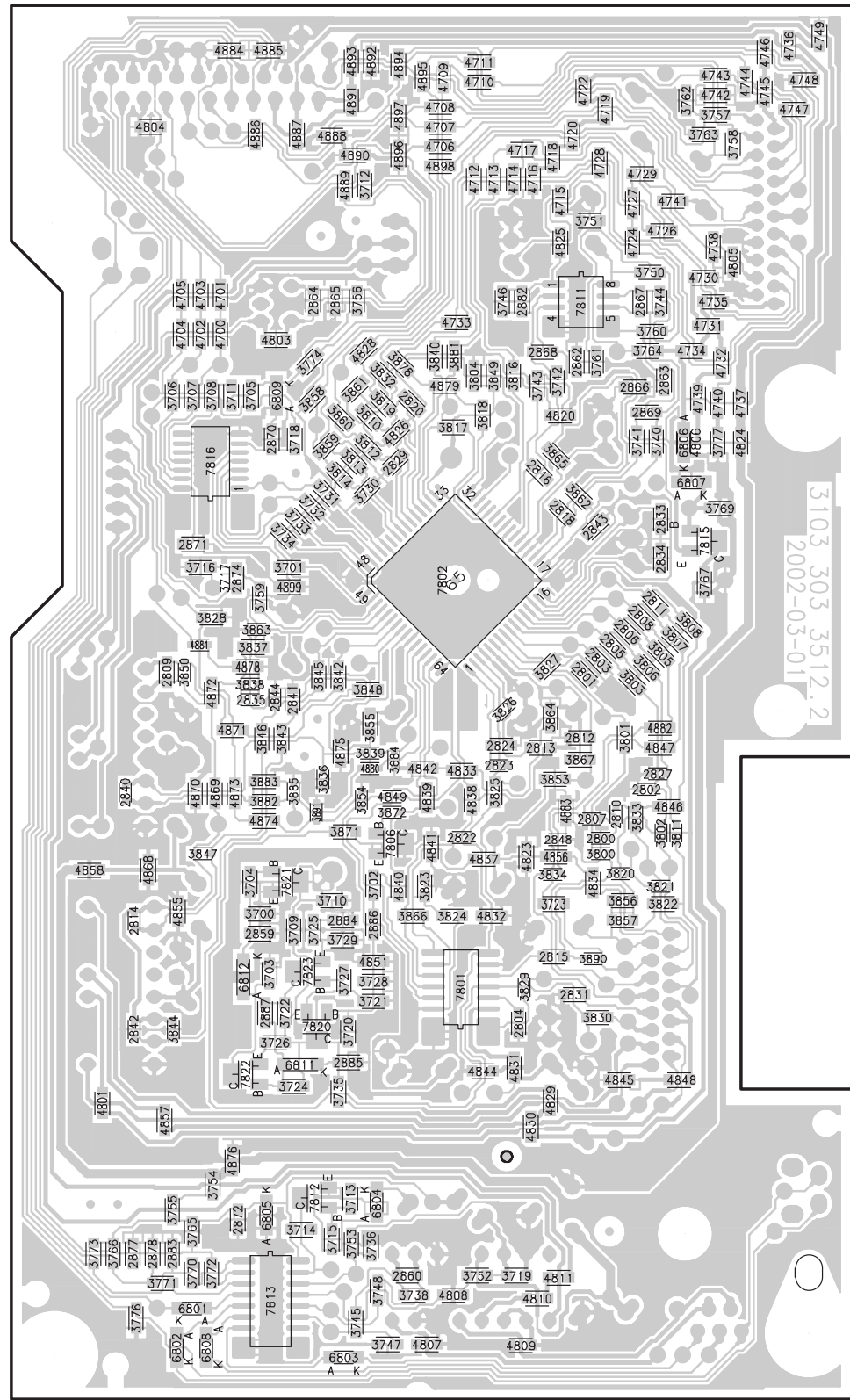

This assembly drawing shows a summary of all possible versions. For components used in a specific version see schematic diagram respectively partslist.

		Copperside		Componentside					
2800	E4	3730	C3	3848	D3	4823	E3	1451	B5
2801	D4	3731	C2	3849	C3	4824	C5	1455	A4
2802	E4	3732	C2	3850	D1	4825	B4	2450	C1
2803	D4	3733	C2	3853	F4	4826	C3	2451	B1
2804	F3	3734	D2	3854	E3	4828	C3	2452	C2
2805	D4	3735	G2	3855	E3	4829	G4	2453	B1
2806	D4	3736	H3	3856	F4	4830	G3	2454	B1
2807	E4	3738	H3	3857	F4	4831	G3	2455	D2
2808	D4	3740	C4	3858	C2	4832	F3	2457	A2
2809	D1	3741	C4	3859	C2	4833	E3	2461	D4
2810	E4	3742	C4	3860	C2	4834	F4	2463	A3
2811	D4	3743	C4	3861	C2	4837	F3	2464	D4
2812	E4	3744	B4	3862	C4	4838	E3	2465	D4
2813	E4	3745	H2	3863	D2	4839	E3	2466	A3
2814	F1	3746	B3	3864	E4	4840	F3	2467	B4
2815	F4	3747	H3	3865	C4	4841	E3	2468	B4
2816	C4	3748	H3	3866	F3	4842	E3	2469	B4
2818	C4	3750	B4	3867	E4	4844	G3	2472	D3
2820	C3	3751	B4	3871	E2	4845	G4	3450	C1
2822	E3	3752	H3	3872	E3	4846	F4	3451	B1
2823	E3	3753	H2	3878	C3	4847	F4	3454	D2
2824	E3	3754	G2	3881	C3	4848	G4	3465	C1
2827	E4	3755	G1	3882	E2	4849	E3	3467	A3
2829	C3	3756	B2	3883	E2	4851	F3	3468	A3
2831	F4	3757	A5	3884	E3	4855	F1	3469	C4
2833	C4	3758	A5	3885	E2	4856	E4	3470	D3
2834	D4	3759	D2	3890	F4	4857	G1	3471	C4
2835	D2	3760	B4	3891	E2	4858	E1	3473	C4
2840	E1	3761	C4	4700	B2	4868	E1	3474	A3
2841	D2	3762	A4	4701	B2	4869	E2	3475	C4
2842	F1	3763	A4	4702	B2	4870	E2	3476	C4
2843	D4	3764	C4	4703	B2	4871	E2	3477	B4
2844	D2	3765	H2	4704	B1	4872	D2	3479	A2
2848	E4	3766	H1	4705	B1	4873	E2	3480	C4
2859	F2	3767	D4	4706	A3	4874	E2	3481	C4
2860	H3	3769	C5	4707	A3	4875	E2	3484	B4
2862	C4	3770	H2	4708	A3	4876	G2	3490	A4
2863	C4	3771	H1	4709	A3	4878	D2	3494	A2
2864	B2	3772	H2	4710	A3	4879	C3	3496	A4
2865	B2	3773	H1	4711	A3	4880	E3	3499	C1
2866	C4	3774	C2	4712	B3	4881	D2	4450	A4
2867	B4	3776	H1	4713	B3	4882	E4	6451	D4
2868	C4	3777	C5	4714	B3	4883	E4	7451	B3
2869	C4	3800	E4	4715	B4	4884	A2	7456	D4
2870	C2	3801	E4	4716	B3	4885	A2	7458	D1
2871	D2	3802	E4	4717	A3	4886	A2		
2872	G2	3803	D4	4718	A4	4887	A2		
2874	D2	3804	C3	4719	A4	4888	A2		
2877	H1	3805	D4	4720	A4	4889	B2		
2878	H1	3806	D4	4722	A4	4890	A2		
2882	B3	3807	D4	4724	B4	4891	A2		
2883	H1	3808	D4	4726	B4	4892	A3		
2884	F2	3810	C3	4727	B4	4893	A2		
2885	G2	3811	E4	4728	A4	4894	A3		
2886	F3	3812	C3	4729	A4	4895	A3		
2887	F2	3813	C2	4730	B4	4896	A3		
3700	F2	3814	C2	4731	B4	4897	A3		
3701	D2	3816	C3	4732	C5	4898	A3		
3702	F3	3817	C3	4733	B3	4899	D2		
3703	F2	3818	C3	4734	C4	6801	H2		
3704	F2	3819	C3	4735	B5	6802	H1		
3705	C2	3820	E4	4736	A5	6803	H2		
3706	C1	3821	F4	4737	C5	6804	G3		
3707	C2	3822	F4	4738	B5	6805	G2		
3708	C2	3823	F3	4739	C4	6806	C4		
3709	F2	3824	F3	4740	C5	6807	C4		
3710	F2	3825	E3	4741	B4	6808	H2		
3711	C2	3826	E3	4742	A5	6809	C2		
3712	B3	3827	D4	4743	A5	6811	G2		
3713	G2	3828	D2	4744	A5	6812	F2		
3714	H2	3829	F3	4745	A5	7801	F3		
3715	H2	3830	F4	4746	A5	7802	D3		
3716	D2	3832	C3	4747	A5	7806	E3		
3717	D2	3833	E4	4748	A5	7811	B4		
3718	C2	3834	E4	4749	A5	7812	G2		
3719	H3	3836	E2	4801	G1	7813	H2		
3720	F2	3837	D2	4803	B2	7815	D4		
3721	F3	3838	D2	4804	A1	7816	C2		
3722	F2	3839	E3	4805	B5	7820	F2		
3723	F4	3840	C3	4806	C4	7821	F2		
3724	G2	3842	D2	4807	H3	7822	G2		
3725	F2	3843	E2	4808	H3	7823	F2		
3726	F2	3844	F1	4809	H3				
3727	F2	3845	D2	4810	H4				
3728	F3	3846	E2	4811	H4				
3729	F2	3847	E2	4820	C4				

3CDC-LC-MP3CD2002 Components seen from Copperside

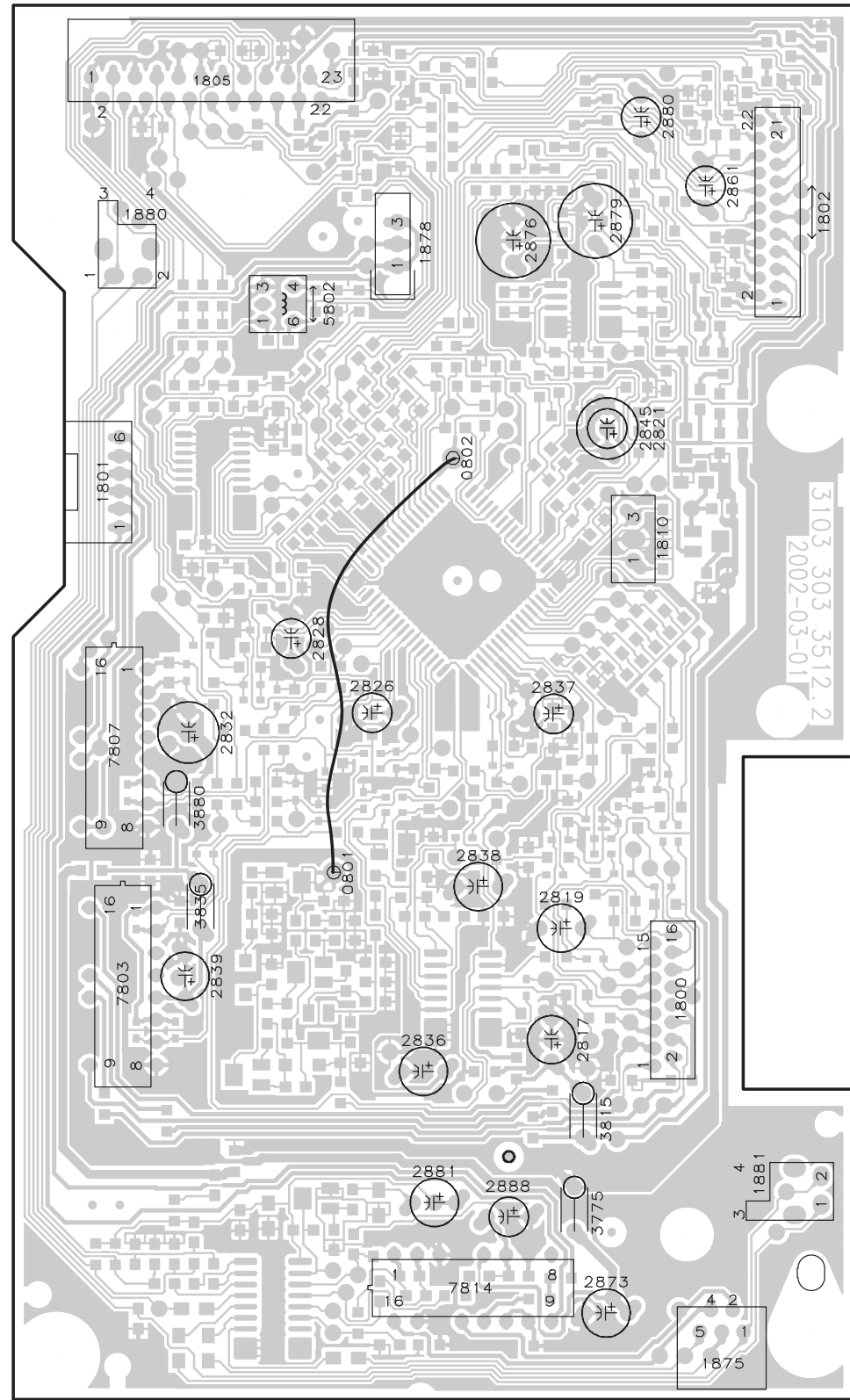

This assembly drawing shows a summary of all possible versions. For components used in a specific version see schematic diagram respectively partslist.

1800	C1	1876	H10	1883	I11	2807	A4	2815	D4	2823	F9	2834	C10	2842	G4	2867	A13	2879	A12	3715	I14	3742	B12	3751	A12	3761	A12	3770	J14	3802	B4	3812	D14	3820	C3	3828	F9	3837	E5	3846	H5	3856	C1	3871	E3	3891	G9	7801	D5	7813	H13
1801	J1	1876	H7	1880	C4	2808	A5	2816	B11	2824	F9	2835	H4	2843	B10	2868	B13	2880	A14	3719	H9	3743	B12	3752	H9	3762	A14	3771	J13	3803	B4	3813	E14	3821	C3	3829	E2	3838	F5	3847	H4	3857	B1	3872	E3	3891	I12	7802	D12	7814	H8
1802	D15	1876	H11	1880	C5	2809	I4	2817	E4	2826	C11	2836	D6	2844	H5	2869	A13	2881	H14	3723	A4	3744	A14	3753	H9	3763	B14	3772	J14	3805	A4	3814	E14	3822	C3	3830	E2	3839	J5	3848	I5	3858	F15	3873	F15	3892	G3	7803	G3	7815	F8
1805	I15	1877	I7	1880	B4	2810	A4	2818	B10	2827	B4	2837	E10	2848	A4	2872	H12	2882	B13	3730	F14	3745	I9	3754	H11	3764	A12	3773	I14	3806	B4	3815	D4	3823	E7	3832	E14	3840	C14	3849	C14	3859	B10	3870	J4	6803	I12	7806	E3		
1810	C9	1878	I7	1880	B5	2811	A5	2819	C1	2828	F6	2838	E7	2850	I9	2873	I9	2883	J14	3736	J11	3746	B14	3755	H11	3765	I14	3775	I9	3807	A4	3816	B13	3824	D7	3833	A4	3842	G5	3850	I4	3863	F6	3881	F15	6804	I14	7807	I3		
1875	H10	1880	I11	1880	D4	2812	E9	2820	D14	2829	F14	2839	H4	2846	B10	2876	I12	2888	H8	3747	J12	3757	A14	3766	I14	3776	H11	3808	A4	3817	B13	3825	D8	3834	A4	3843	G5	3853	E9	3864	F9	3882	J5	6805	H12	7811	A13				
1875	H12	1881	I11	1880	B5	2813	F9	2821	B11	2830	F14	2840	J4	2847	J14	2877	J14	2887	H14	3740	A11	3748	I9	3757	F7	3767	F7	3800	B4	3810	D14	3819	D14	3827	E10	3836	J4	3845	H5	3855	G12	3866	D6	3880	C3	6806	G6	7812	H13		

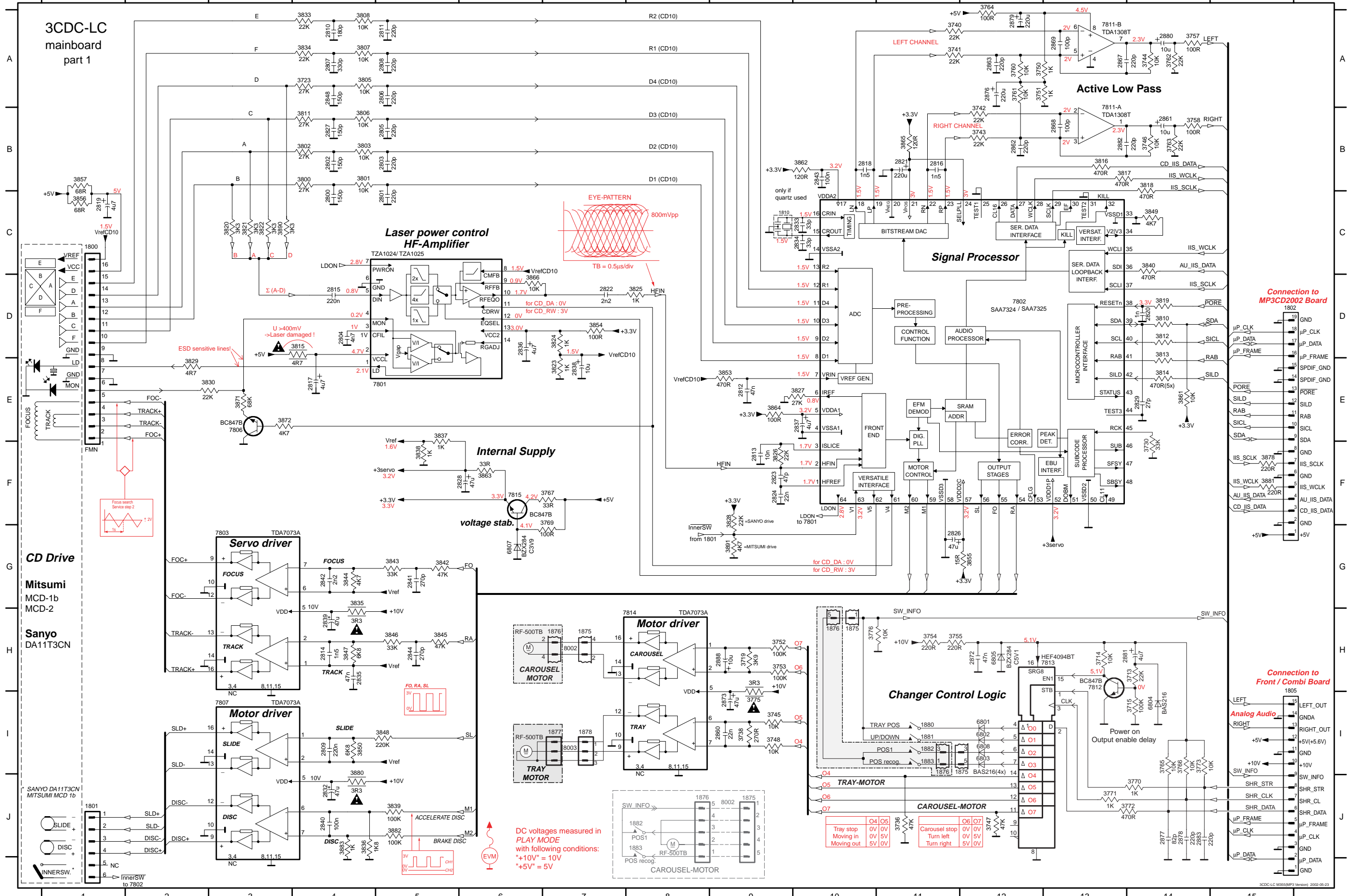

1460 A3	3449 C3	3460 C2	3482 B2	3492 A3	6450 C2
2456 A4	3452 B2	3461 B5	3483 B2	3493 B2	7450 B4
2458 D4	3453 A4	3462 C3	3485 B2	3495 B2	7452 C2
2459 D4	3455 B5	3463 C3	3486 A2	3497 B2	7453 C2
2460 D2	3456 D4	3464 C2	3487 A2	3498 D3	7454 C3
2462 C4	3457 D3	3466 A3	3488 B3	4452 A3	7455 D2
2470 B4	3458 D3	3472 D2	3489 B3	4453 B2	7457 B4
2471 C3	3459 C2	3478 B2	3491 B4	5450 D3	7460 B2

1451 B5	2457 A2	2469 B4	3469 C4	3479 A2	4450 A4
1455 A4	2461 D4	2472 D3	3470 D3	3480 C4	6451 D4
2450 C1	2463 A3	3450 C1	3471 C4	3481 C4	7451 B3
2451 B1	2464 D4	3451 B1	3473 C4	3484 B4	7456 D4
2452 C2	2465 D4	3454 D2	3474 A3	3490 A4	7458 D1
2453 B1	2466 A3	3465 C1	3475 C4	3494 A2	
2454 B1	2467 B4	3467 A3	3476 C4	3496 A4	
2455 D2	2468 B4	3468 A3	3477 B4	3499 C1	

1 2 3 4 5

Side A

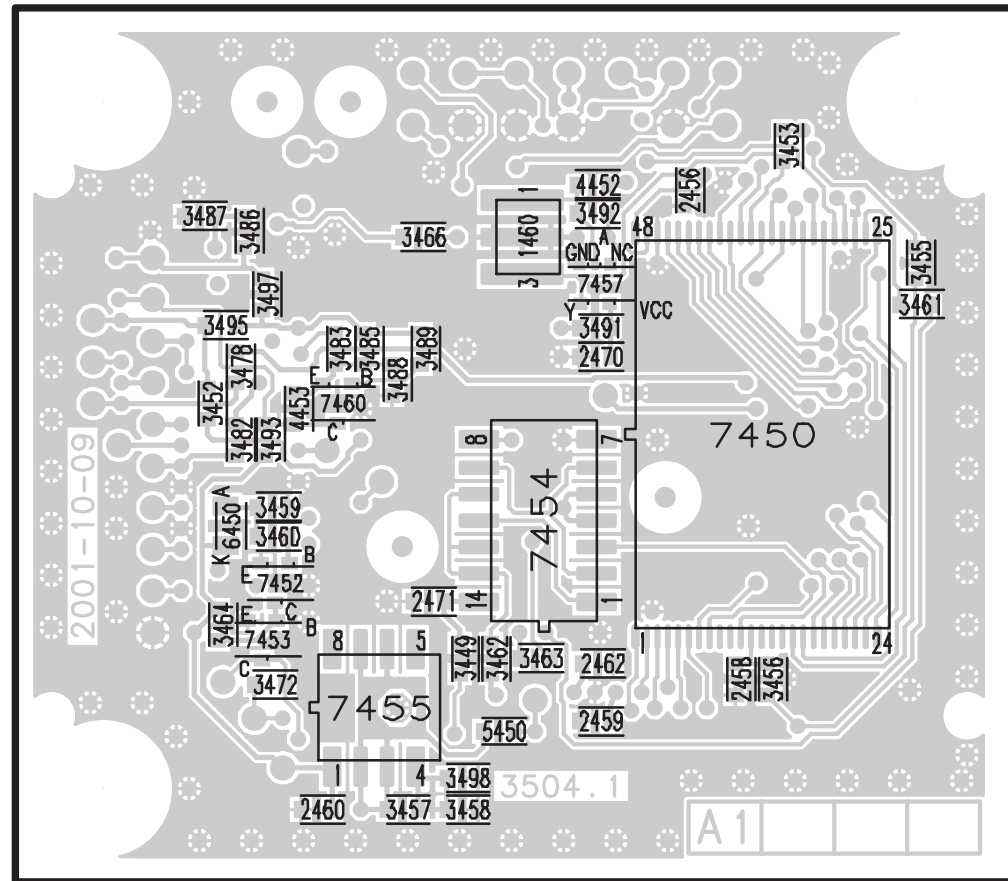

This assembly drawing shows a summary of all possible versions. For components used in a specific version see schematic diagram respectively partlist.

1 2 3 4 5

1 2 3 4 5

Side B

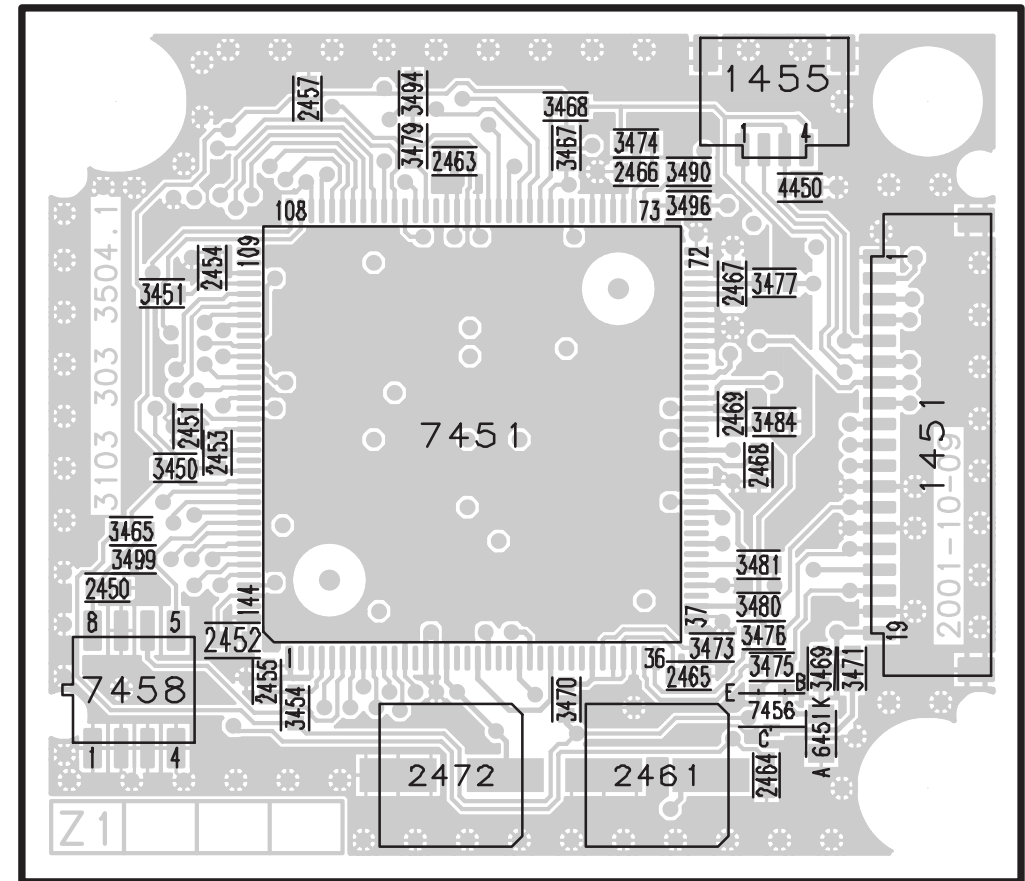

1 2 3 4 5

MP3-CD-2002

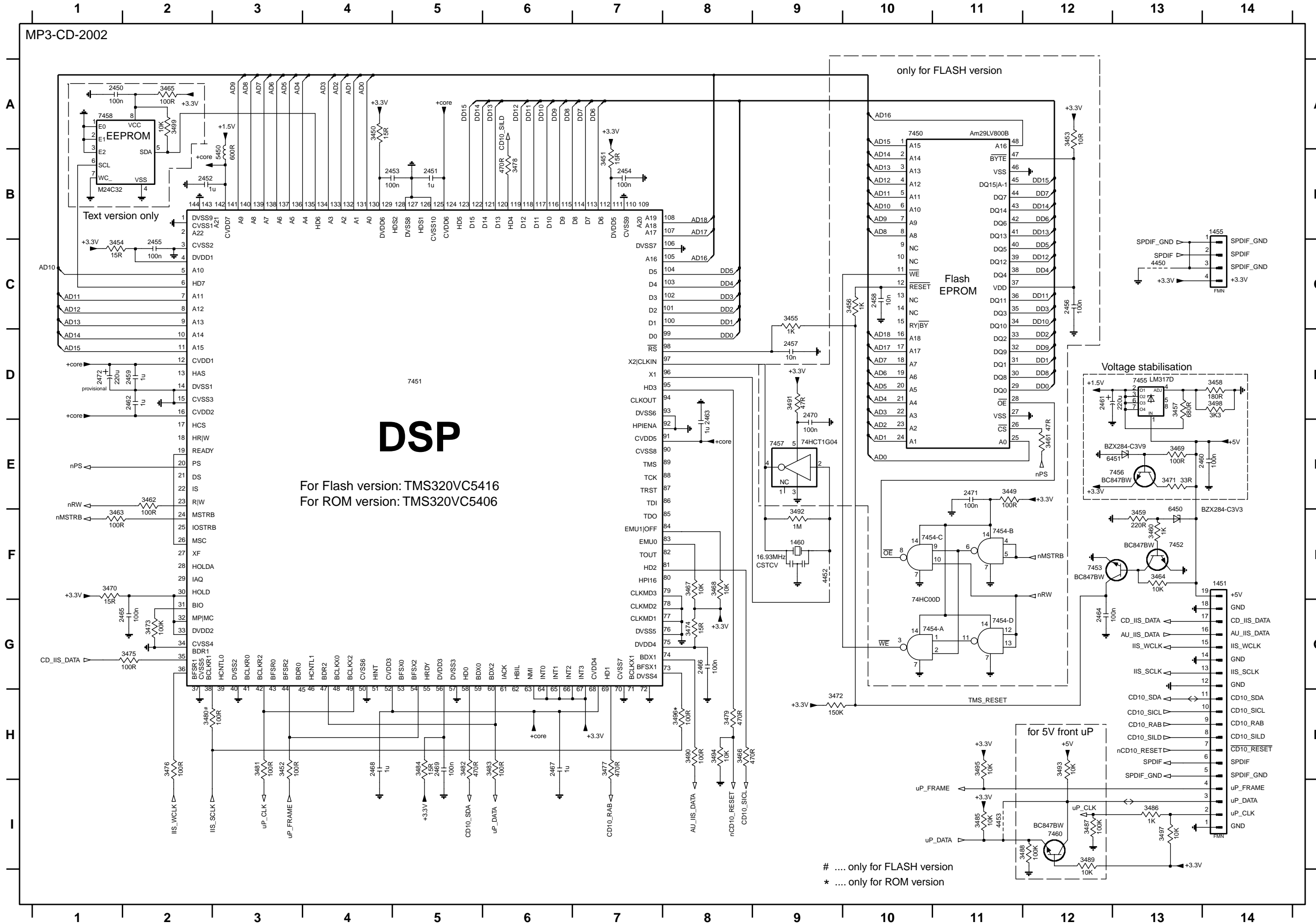

DSP

For Flash version: TMS320VC5416
 For ROM version: TMS320VC5406

.... only for FLASH version
 * only for ROM version

- 2451 B5
- 2452 B2
- 2453 B4
- 2454 B7
- 2455 C2
- 2456 C12
- 2457 D9
- 2458 C10
- 2459 D2
- 2460 E13
- 2461 D12
- 2462 D2
- 2463 D8
- 2464 G12
- 2465 G2
- 2466 G8
- 2467 H6
- 2468 H4
- 2469 H5
- 2470 D9
- 2471 E11
- 2472 D1
- 3449 E11
- 3450 A4
- 3451 B7
- 3452 H3
- 3453 A12
- 3454 C1
- 3455 C9
- 3456 C10
- 3457 D13
- 3458 D14
- 3459 F13
- 3460 F12
- 3461 E12
- 3462 E2
- 3463 F1
- 3464 F13
- 3465 A2
- 3466 H8
- 3467 F8
- 3468 F8
- 3469 E13
- 3470 F1
- 3471 E13
- 3472 H9
- 3473 G2
- 3474 G8
- 3475 G2
- 3476 H2
- 3477 H1
- 3478 B6
- 3479 H8
- 3480 H2
- 3481 H3
- 3482 H5
- 3483 H6
- 3484 H5
- 3485 H11
- 3486 H13
- 3487 I2
- 3488 I2
- 3489 I2
- 3490 H8
- 3491 D9
- 3492 F9
- 3493 H12
- 3494 H8
- 3495 H11
- 3496 H8
- 3497 I3
- 3498 D14
- 3499 A2
- 4450 C13
- 4452 F9
- 4453 I11
- 5450 B3
- 6450 E13
- 6451 E13
- 7450 A10
- 7451 D5
- 7452 F13
- 7453 F12
- 7454-A G11
- 7454-B F11
- 7454-C F11
- 7454-D G11
- 7455 D13
- 7457 E9
- 7458 A1
- 7460 H2

EXPLODED VIEW (3CDC-LC MODULE)

MECHANICAL PARTS Loader

20	3103 304 66500	DRAWER BLACK
21	3140 114 29070	PRESSURE RING-DA11
23	3140 111 21270	METAL RING-DA11
30	3103 304 66560	SUPPORT
31	4822 529 10386	RUBBER DAMPER CD DRIVE, REAR
32	4822 529 10387	RUBBER DAMPER CD DRIVE, FRONT
33	3103 304 06970	WASHER
35	3103 309 05350	CD DRIVE MCD1B
41	3103 304 66480	FRAME
42	3103 304 66540	BRACKET-GUIDING
43	3103 301 06460	SPRING-GUIDING
44	3103 304 06890	GEAR-3
45	3103 304 06980	NAIL FIXATION
46	3103 304 06880	GEAR-2
47	3103 304 66530	BRACKET-LOAD
48	3103 304 06910	CAM
49	3103 304 66510	GUIDING
51	3103 304 06900	GEAR-4
52	3103 304 06870	GEAR-1
53	3103 304 06960	PULLEY-FRAME
54	3103 304 66910	DRIVING-BELT-DRAWER
55	4822 361 10753	TRAY MOTOR
56	4822 502 12548	SCREW M2,6X3,5
57	3103 304 69880	COVER-DA11
59	4822 466 12146	RUBBER

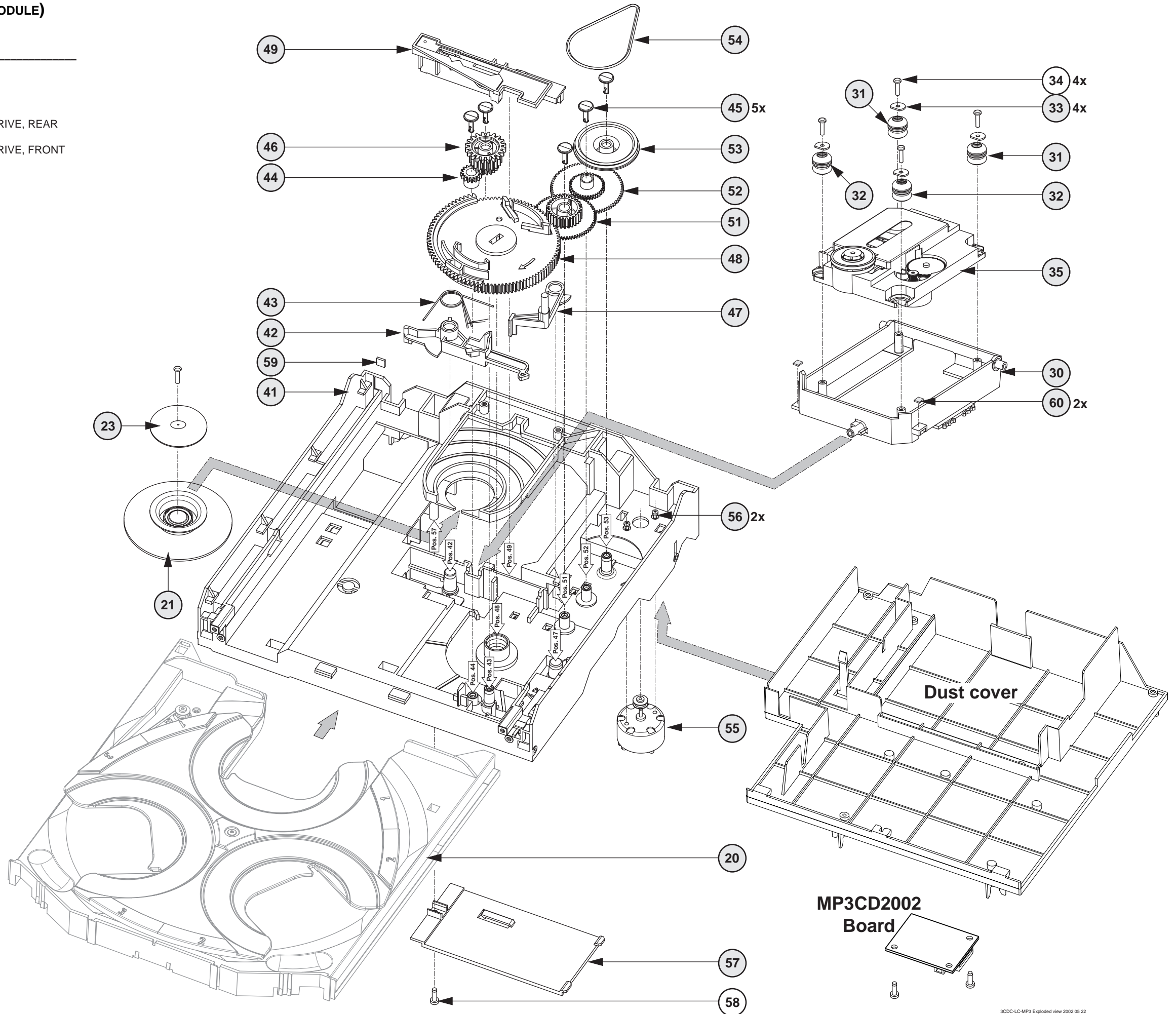

- X** spare part
- Y** non spare part

Drawer bottom view

MECHANICAL PARTS *Drawer*

20	3103 304 66500	DRAWER BLACK
21	3103 304 66490	CAROUSEL BLACK
22	3103 304 06860	PULLEY-DRAWER
23	3103 304 06850	ECCENTRIC GEAR WHEEL
24	3103 304 06980	NAIL FIXATION
25	3103 304 66850	DRIVING BELT CAROUSEL
27	4822 532 12365	BUSH DRAWER (height=5,5mm,d=9,4mm)
29	3103 304 66550	BRACKET-DISC
30	3103 304 66520	TUMBLER
31	3103 301 06470	SPRING-DISC
32	3103 304 06920	CONTROL-DISC
34	3103 304 06870	GEAR-1
37	4822 361 10753	CAROUSEL MOTOR

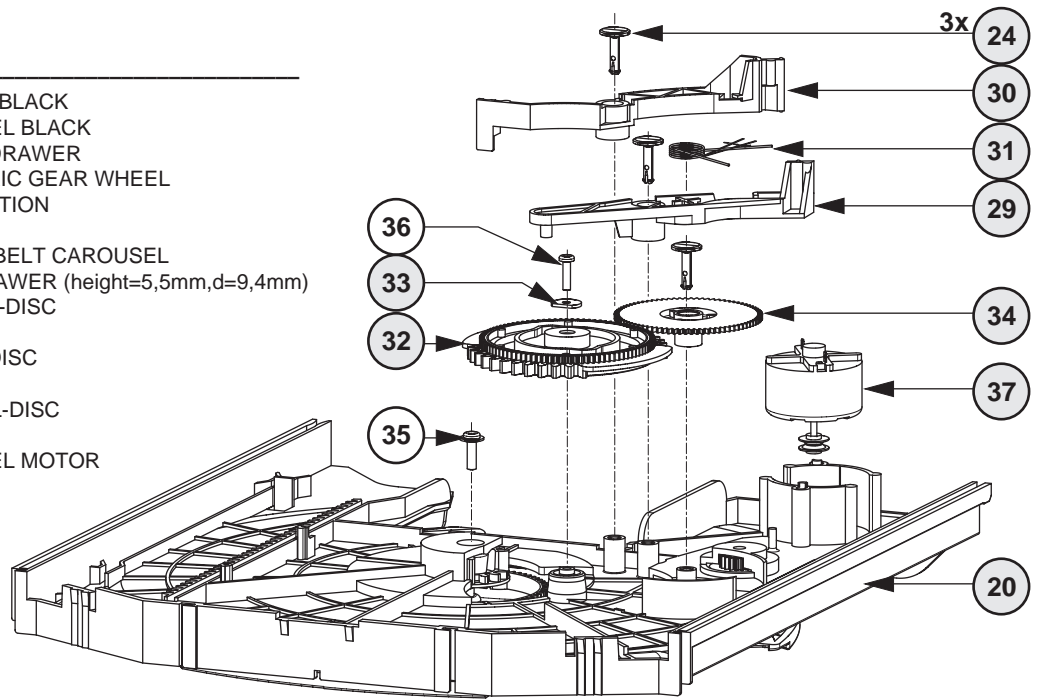

Drawer top view

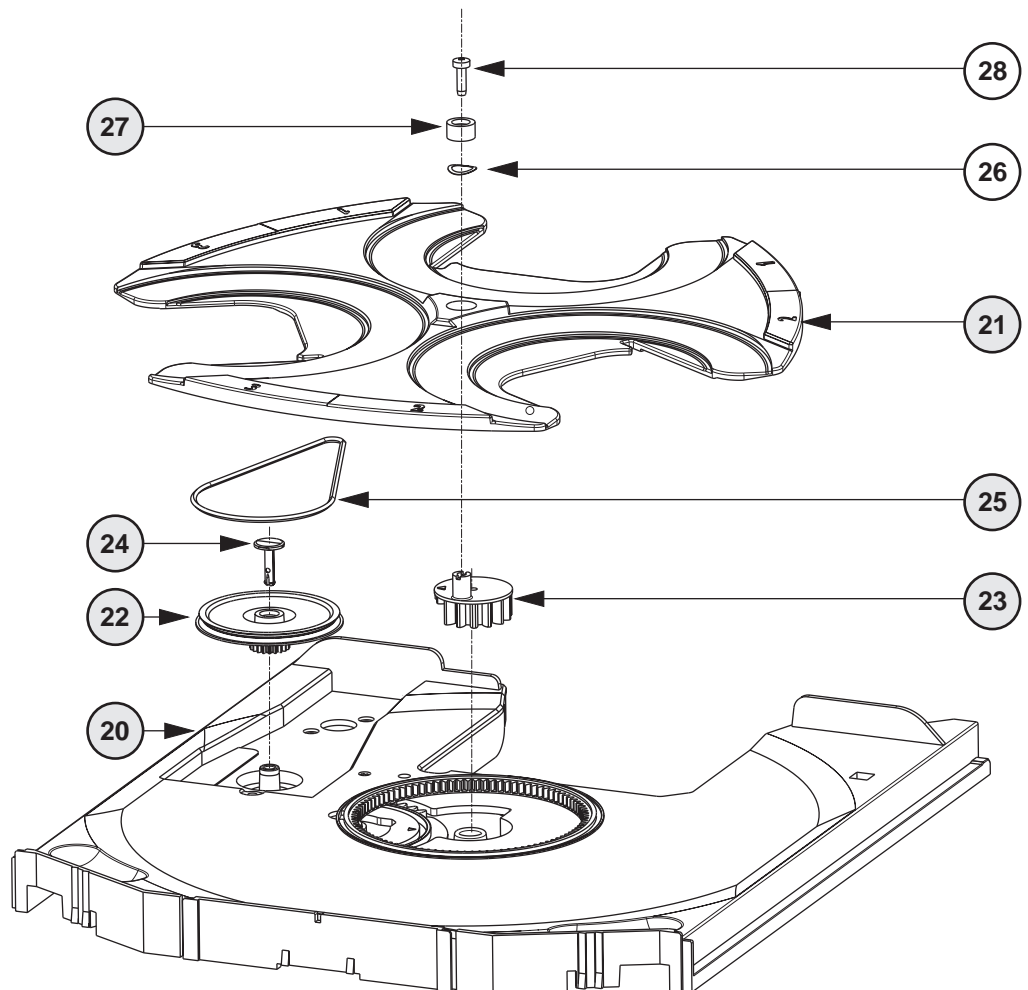

- X spare part
- Y non spare part

ELECTRICAL PARTSLIST 3CDC-LC MODULE**MISCELLANEOUS**

37	4822 361 10753	CAROUSEL MOTOR
55	4822 361 10753	TRAY MOTOR
1800	2422 025 17389	FFC-CONNECTOR 16Pin
1805	4822 265 10979	FFC-CONNECTOR 15Pin
1875	4822 267 10958	FFC-CONNECTOR 5Pin
1876	2422 025 08332	FFC-CONNECTOR 5Pin
1880	4822 276 13503	SWITCH
1881	4822 276 13503	SWITCH
1882	4822 276 13503	SWITCH
1883	4822 276 13503	SWITCH
8001	3103 308 93070	FLEX FOIL CABLE 19P, 170mm BD
8002	3103 308 91990	FLEXFOIL CABLE, 5P, 200mm AD
8005	3103 308 92930	FLEX FOIL CABLE 16P 170mm 1:n

CAPACITORS

2800©	4822 122 33753	150pF	5%	50V
2801©	4822 126 13883	220pF	5%	50V
2802©	4822 122 33753	150pF	5%	50V
2803©	4822 126 13883	220pF	5%	50V
2804©	4822 126 13193	4,7nF	10%	63V
2805©	4822 126 13883	220pF	5%	50V
2806©	4822 126 13883	220pF	5%	50V
2807©	4822 126 14241	330pF		50V
2808©	4822 126 13883	220pF	5%	50V
2809©	4822 126 13879	220nF	20%	16V
2810©	4822 126 14508	180pF	5%	50V
2811©	4822 126 13883	220pF	5%	50V
2812©	3198 024 44730	47nF	5%	50V
2813©	4822 122 33177	10nF	20%	50V
2814©	4822 126 14247	1,5nF	10%	50V
2815©	4822 126 14076	220nF	20%	25V
2816©	4822 126 13344	1,5nF	5%	63V
2817	4822 124 40769	4,7µF	20%	100V
2818©	4822 126 13344	1,5nF	5%	63V
2819	4822 124 40769	4,7µF	20%	100V
2820©	5322 126 11578	1nF	10%	63V
2821	4822 124 42383	220µF	20%	4V
2822©	4822 126 14238	2,2nF	10%	50V
2823©	4822 126 11785	47pF	5%	50V
2824©	5322 122 32654	22nF	10%	63V
2826	4822 124 12362	47µF	20%	4V
2827©	4822 122 33753	150pF	5%	50V
2828	4822 124 12362	47µF	20%	4V
2829©	4822 126 11669	27pF	10%	50V
2832	4822 124 40433	47µF	20%	25V
2833©	2222 867 15339	33pF	5%	50V
2835©	3198 024 44730	47nF	5%	50V
2836	4822 124 40769	4,7µF	20%	100V
2837	4822 124 22726	4,7µF	20%	35V
2838	4822 124 40248	10µF	20%	63V
2839	4822 124 40433	47µF	20%	25V
2840©	4822 126 14585	100nF	10%	50V
2841©	4822 122 33216	270pF	5%	50V
2842©	4822 126 14238	2,2nF	10%	50V
2843©	4822 126 14585	100nF	10%	50V
2844©	4822 122 33216	270pF	5%	50V
2848©	4822 122 33753	150pF	5%	50V
2860©	4822 126 14494	22nF	10%	25V
2861	4822 124 11947	10µF	20%	16V
2862©	4822 126 13883	220pF	5%	50V
2863©	4822 126 13883	220pF	5%	50V
2865©	5322 122 32654	22nF	10%	63V
2866©	4822 126 13751	47nF	10%	50V

CAPACITORS

2867©	4822 126 13883	220pF	5%	50V
2868©	2020 552 94427	100pF	5%	50V
2869©	2020 552 94427	100pF	5%	50V
2872©	3198 024 44730	47nF	5%	50V
2873	4822 124 80231	47µF	20%	16V
2876	4822 124 12245	220µF	20%	16V
2877©	4822 126 14226	82pF		50V
2878©	4822 126 13883	220pF	5%	50V
2879	4822 124 12245	220µF	20%	16V
2880	4822 124 11947	10µF	20%	16V
2881	4822 124 40769	4,7µF	20%	100V
2882©	4822 126 13883	220pF	5%	50V
2888	4822 124 11947	10µF	20%	16V

RESISTORS

3713©	4822 051 30223	22kΩ	5%	0,06W
3714©	4822 051 30103	10kΩ	5%	0,06W
3715©	4822 117 13632	100kΩ	1%	0,06W
3719©	4822 051 30392	3,9kΩ	5%	0,06W
3723©	4822 051 20273	27kΩ	5%	0,1W
3730©	4822 051 20333	33kΩ	5%	0,1W
3736©	4822 117 12925	47kΩ	1%	0,06W
3738©	4822 051 30271	270Ω	5%	0,06W
3740©	4822 051 20223	22kΩ	5%	0,1W
3741©	4822 051 20223	22kΩ	5%	0,1W
3742©	4822 051 20223	22kΩ	5%	0,1W
3743©	4822 051 20223	22kΩ	5%	0,1W
3744©	4822 051 30103	10kΩ	5%	0,06W
3745©	4822 117 10833	10kΩ	1%	0,1W
3746©	4822 051 30103	10kΩ	5%	0,06W
3747©	4822 117 12925	47kΩ	1%	0,06W
3748©	4822 051 30103	10kΩ	5%	0,06W
3750©	4822 051 30102	1kΩ	5%	0,06W
3751©	4822 051 30102	1kΩ	5%	0,06W
3752©	4822 117 13632	100kΩ	1%	0,06W
3753©	4822 117 13632	100kΩ	1%	0,06W
3754©	4822 051 30221	220Ω	5%	0,06W
3755©	4822 117 11503	220Ω	5%	0,1W
3757©	4822 117 11373	100Ω	1%	0,1W
3758©	4822 051 30101	100Ω	5%	0,06W
3760©	4822 117 10833	10kΩ	1%	0,1W
3761©	4822 051 30103	10kΩ	5%	0,06W
3762©	4822 051 30223	22kΩ	5%	0,06W
3763©	4822 051 30223	22kΩ	5%	0,06W
3764©	4822 117 11373	100Ω	1%	0,1W
3765©	4822 051 30103	10kΩ	5%	0,06W
3766©	4822 117 10833	10kΩ	1%	0,1W
3767©	4822 051 30339	33Ω	5%	0,06W
3769©	4822 051 30101	100Ω	5%	0,06W
3770©	4822 051 30102	1kΩ	5%	0,06W
3771©	4822 051 30102	1kΩ	5%	0,06W
3772©	4822 051 30471	470Ω	5%	0,06W
3773©	4822 117 10833	10kΩ	1%	0,1W
3774©	4822 117 11373	100Ω	1%	0,1W
3775▲	4822 052 10338	3,3Ω	5%	NFR25
3776©	4822 051 30103	10kΩ	5%	0,06W
3800©	4822 051 30273	27kΩ	5%	0,06W
3801©	4822 117 10833	10kΩ	1%	0,1W
3802©	4822 051 30273	27kΩ	5%	0,06W
3803©	4822 117 10833	10kΩ	1%	0,1W
3805©	4822 051 30103	10kΩ	5%	0,06W
3806©	4822 051 30103	10kΩ	5%	0,06W
3807©	4822 051 30103	10kΩ	5%	0,06W
3808©	4822 051 30103	10kΩ	5%	0,06W

ELECTRICAL PARTSLIST 3CDC-LC MODULE

RESISTORS

3810	©	4822 051 30471	470Ω	5%	0,06W
3811	©	4822 051 30273	27kΩ	5%	0,06W
3812	©	4822 051 20471	470Ω	5%	0,1W
3813	©	4822 051 20471	470Ω	5%	0,1W
3814	©	4822 051 20471	470Ω	5%	0,1W
3815	▲	4822 052 10478	4,7Ω	5%	NFR25
3816	©	4822 051 20471	470Ω	5%	0,1W
3817	©	4822 051 30471	470Ω	5%	0,06W
3818	©	4822 051 30471	470Ω	5%	0,06W
3819	©	4822 051 20471	470Ω	5%	0,1W
3820	©	4822 051 30332	3,3kΩ	5%	0,06W
3821	©	4822 051 30332	3,3kΩ	5%	0,06W
3822	©	4822 051 20332	3,3kΩ	5%	0,1W
3823	©	4822 051 30102	1kΩ	5%	0,06W
3824	©	4822 051 30102	1kΩ	5%	0,06W
3825	©	4822 051 10102	1kΩ	2%	0,25W
3826	©	4822 051 30223	22kΩ	5%	0,06W
3827	©	4822 051 20273	27kΩ	5%	0,1W
3829	©	4822 117 13608	4,7Ω	5%	0,06W
3830	©	4822 051 20223	22kΩ	5%	0,1W
3833	©	4822 051 30223	22kΩ	5%	0,06W
3834	©	4822 051 30223	22kΩ	5%	0,06W
3835	▲	4822 052 10338	3,3Ω	5%	NFR25
3836	©	4822 117 12903	1,8kΩ	1%	0,06W
3837	©	4822 051 10102	1kΩ	2%	0,25W
3838	©	4822 051 30102	1kΩ	5%	0,06W
3839	©	4822 117 13632	100kΩ	1%	0,06W
3840	©	4822 051 20471	470Ω	5%	0,1W
3842	©	4822 117 10834	47kΩ	1%	0,1W
3843	©	4822 051 20333	33kΩ	5%	0,1W
3844	©	4822 051 30472	4,7kΩ	5%	0,06W
3845	©	4822 117 10834	47kΩ	1%	0,1W
3846	©	4822 051 20333	33kΩ	5%	0,1W
3847	©	4822 051 30682	6,8kΩ	5%	0,06W
3848	©	3198 021 52240	220kΩ	5%	0,1W
3849	©	4822 051 30472	4,7kΩ	5%	0,06W
3850	©	4822 051 30682	6,8kΩ	5%	0,06W
3853	©	4822 051 20471	470Ω	5%	0,1W
3854	©	4822 117 11373	100Ω	1%	0,1W
3855	©	4822 117 12971	15Ω	5%	0,06W
3856	©	4822 117 12521	68Ω	1%	0,1W
3857	©	4822 117 12521	68Ω	1%	0,1W
3861	©	4822 051 30103	10kΩ	5%	0,06W
3862	©	4822 051 20121	120Ω	5%	0,1W
3863	©	4822 051 30339	33Ω	5%	0,06W
3864	©	4822 051 30101	100Ω	5%	0,06W
3865	©	4822 051 30121	120Ω	5%	0,06W
3866	©	4822 051 30103	10kΩ	5%	0,06W
3871	©	4822 051 20683	68kΩ	5%	0,1W
3872	©	4822 051 30472	4,7kΩ	5%	0,06W
3878	©	4822 117 11503	220Ω	5%	0,1W
3880	▲	4822 052 10338	3,3Ω	5%	NFR25
3881	©	4822 117 11503	220Ω	5%	0,1W
3882	©	4822 117 10837	100kΩ	1%	0,1W
3883	©	4822 051 10102	1kΩ	2%	0,25W
3890	©	4822 051 30332	3,3kΩ	5%	0,06W
3891	©	4822 051 30472	4,7kΩ	5%	0,06W
4700	©	4822 051 20008	CHIP JUMPER		0805
4701	©	4822 051 20008	CHIP JUMPER		0805
4702	©	4822 051 20008	CHIP JUMPER		0805
4703	©	4822 051 20008	CHIP JUMPER		0805
4704	©	4822 051 20008	CHIP JUMPER		0805
4705	©	4822 051 20008	CHIP JUMPER		0805
4706	©	4822 051 20008	CHIP JUMPER		0805

RESISTORS

4707	©	4822 051 20008	CHIP JUMPER		0805
4708	©	4822 051 20008	CHIP JUMPER		0805
4709	©	4822 051 20008	CHIP JUMPER		0805
4710	©	4822 051 20008	CHIP JUMPER		0805
4711	©	4822 051 20008	CHIP JUMPER		0805
4712	©	4822 051 20008	CHIP JUMPER		0805
4713	©	4822 051 20008	CHIP JUMPER		0805
4714	©	4822 051 20008	CHIP JUMPER		0805
4715	©	4822 051 20008	CHIP JUMPER		0805
4716	©	4822 051 20008	CHIP JUMPER		0805
4717	©	4822 051 30008	CHIP JUMPER		0603
4718	©	4822 051 20008	CHIP JUMPER		0805
4719	©	4822 051 20008	CHIP JUMPER		0805
4720	©	4822 051 20008	CHIP JUMPER		0805
4722	©	4822 051 20008	CHIP JUMPER		0805
4724	©	4822 051 20008	CHIP JUMPER		0805
4726	©	4822 051 20008	CHIP JUMPER		0805
4727	©	4822 051 20008	CHIP JUMPER		0805
4728	©	4822 051 20008	CHIP JUMPER		0805
4729	©	4822 051 20008	CHIP JUMPER		0805
4730	©	4822 051 20008	CHIP JUMPER		0805
4731	©	4822 051 30008	CHIP JUMPER		0603
4732	©	4822 051 20008	CHIP JUMPER		0805
4733	©	4822 051 30008	CHIP JUMPER		0603
4734	©	4822 051 20008	CHIP JUMPER		0805
4735	©	4822 051 20008	CHIP JUMPER		0805
4736	©	4822 051 30008	CHIP JUMPER		0603
4737	©	4822 051 30008	CHIP JUMPER		0603
4738	©	4822 051 30008	CHIP JUMPER		0603
4739	©	4822 051 30008	CHIP JUMPER		0603
4740	©	4822 051 30008	CHIP JUMPER		0603
4741	©	4822 051 20008	CHIP JUMPER		0805
4742	©	4822 051 20008	CHIP JUMPER		0805
4743	©	4822 051 20008	CHIP JUMPER		0805
4744	©	4822 051 30008	CHIP JUMPER		0603
4745	©	4822 051 20008	CHIP JUMPER		0805
4746	©	4822 051 20008	CHIP JUMPER		0805
4747	©	4822 051 20008	CHIP JUMPER		0805
4748	©	4822 051 20008	CHIP JUMPER		0805
4749	©	4822 051 30008	CHIP JUMPER		0603
4801	©	4822 051 20008	CHIP JUMPER		0805
4804	©	4822 051 20008	CHIP JUMPER		0805
4806	©	4822 051 20008	CHIP JUMPER		0805
4807	©	4822 051 20008	CHIP JUMPER		0805
4808	©	4822 051 20008	CHIP JUMPER		0805
4809	©	4822 051 20008	CHIP JUMPER		0805
4810	©	4822 051 20008	CHIP JUMPER		0805
4811	©	4822 051 20008	CHIP JUMPER		0805
4820	©	4822 051 20008	CHIP JUMPER		0805
4823	©	4822 051 30008	CHIP JUMPER		0603
4824	©	4822 051 30008	CHIP JUMPER		0603
4825	©	4822 051 20008	CHIP JUMPER		0805
4826	©	4822 051 20008	CHIP JUMPER		0805
4828	©	4822 051 30008	CHIP JUMPER		0603
4829	©	4822 051 20008	CHIP JUMPER		0805
4830	©	4822 051 20008	CHIP JUMPER		0805
4831	©	4822 051 20008	CHIP JUMPER		0805
4832	©	4822 051 30008	CHIP JUMPER		0603
4833	©	4822 051 20008	CHIP JUMPER		0805
4834	©	4822 051 20008	CHIP JUMPER		0805
4837	©	4822 051 20008	CHIP JUMPER		0805
4838	©	4822 051 30008	CHIP JUMPER		0603
4839	©	4822 051 20008	CHIP JUMPER		0805
4840	©	4822 051 20008	CHIP JUMPER		0805

ELECTRICAL PARTSLIST 3CDC-LC MODULE**RESISTORS**

4841 ©	4822 051 20008	CHIP JUMPER 0805
4842 ©	4822 051 20008	CHIP JUMPER 0805
4844 ©	4822 051 20008	CHIP JUMPER 0805
4845 ©	4822 051 20008	CHIP JUMPER 0805
4846 ©	4822 051 20008	CHIP JUMPER 0805
4847 ©	4822 051 20008	CHIP JUMPER 0805
4848 ©	4822 051 20008	CHIP JUMPER 0805
4849 ©	4822 051 30008	CHIP JUMPER 0603
4851 ©	4822 051 30008	CHIP JUMPER 0603
4855 ©	4822 051 20008	CHIP JUMPER 0805
4856 ©	4822 051 20008	CHIP JUMPER 0805
4857 ©	4822 051 20008	CHIP JUMPER 0805
4858 ©	4822 051 20008	CHIP JUMPER 0805
4868 ©	4822 051 20008	CHIP JUMPER 0805
4869 ©	4822 051 20008	CHIP JUMPER 0805
4870 ©	4822 051 20008	CHIP JUMPER 0805
4871 ©	4822 051 20008	CHIP JUMPER 0805
4872 ©	4822 051 20008	CHIP JUMPER 0805
4873 ©	4822 051 20008	CHIP JUMPER 0805
4874 ©	4822 051 20008	CHIP JUMPER 0805
4875 ©	4822 051 20008	CHIP JUMPER 0805
4876 ©	4822 051 20008	CHIP JUMPER 0805
4878 ©	4822 051 20008	CHIP JUMPER 0805
4879 ©	4822 051 20008	CHIP JUMPER 0805
4880 ©	4822 051 20008	CHIP JUMPER 0805
4882 ©	4822 051 20008	CHIP JUMPER 0805
4883 ©	4822 051 20008	CHIP JUMPER 0805
4884 ©	4822 051 20008	CHIP JUMPER 0805
4885 ©	4822 051 20008	CHIP JUMPER 0805
4886 ©	4822 051 20008	CHIP JUMPER 0805
4887 ©	4822 051 30008	CHIP JUMPER 0603
4888 ©	4822 051 20008	CHIP JUMPER 0805
4889 ©	4822 051 20008	CHIP JUMPER 0805
4890 ©	4822 051 20008	CHIP JUMPER 0805
4891 ©	4822 051 30008	CHIP JUMPER 0603

RESISTORS

4892 ©	4822 051 20008	CHIP JUMPER 0805
4893 ©	4822 051 20008	CHIP JUMPER 0805
4894 ©	4822 051 20008	CHIP JUMPER 0805
4895 ©	4822 051 20008	CHIP JUMPER 0805
4896 ©	4822 051 20008	CHIP JUMPER 0805
4897 ©	4822 051 20008	CHIP JUMPER 0805
4898 ©	4822 051 20008	CHIP JUMPER 0805
4899 ©	4822 051 20008	CHIP JUMPER 0805

COILS

1810	2422 540 98519	RESONATOR 8,467MHz
------	----------------	--------------------

DIODES

6801 ©	4822 130 11397	BAS316
6802 ©	4822 130 11397	BAS316
6803 ©	4822 130 11397	BAS316
6804 ©	4822 130 11397	BAS316
6805 ©	9340 548 52115	BZX284-C5V1
6807 ©	9322 129 34685	BZX284-C3V9
6808 ©	4822 130 11397	BAS316
6809 ©	9322 129 34685	BZX284-C3V9

TRANSISTORS

7806 ©	5322 130 60159	BC846B
7812 ©	5322 130 60159	BC846B
7815 ©	5322 130 60159	BC846B

INTEGRATED CIRCUITS

7801 ©	9352 622 36118	TZA1025T/V2 HF-Amplifier
7802 ©	9352 641 80557	SAA7324H/M2B, "CD10" SIGN.PROC.
7803	4822 209 32852	TDA7073A/N2
7807	4822 209 32852	TDA7073A/N2
7811 ©	4822 209 33165	TDA1308T/N1
7813 ©	5322 209 11306	HEF4094BT, SHIFT REGISTER
7814	4822 209 32852	TDA7073A/N2

ELECTRICAL PARTSLIST MP3CD2002 MODULE**MISCELLANEOUS**

1451 **3103 308 67020** complete MP3CD2002 Module
2422 025 17303 FLEX FOIL CONNECTOR 19P

CAPACITORS

2450© 2238 586 59812 100nF 10% 50V
2451© 3198 017 41050 1µF 20% 10V
2452© 3198 017 41050 1µF 20% 10V
2453© 2238 586 59812 100nF 10% 50V
2454© 2238 586 59812 100nF 10% 50V

2455© 2238 586 59812 100nF 10% 50V
2456© 2238 586 59812 100nF 10% 50V
2457© 5322 126 11583 10nF 10% 63V
2458© 5322 126 11583 10nF 10% 63V
2459© 3198 017 41050 1µF 20% 10V

2460© 2238 586 59812 100nF 10% 50V
2461© 4822 124 81059 220µF 20% 4V
2462© 3198 017 41050 1µF 20% 10V
2463© 3198 017 41050 1µF 20% 10V
2464© 2238 586 59812 100nF 10% 50V

2465© 2238 586 59812 100nF 10% 50V
2466© 2238 586 59812 100nF 10% 50V
2467© 3198 017 41050 1µF 20% 10V
2468© 3198 017 41050 1µF 20% 10V
2469© 2238 586 59812 100nF 10% 50V

2470© 2238 586 59812 100nF 10% 50V
2471© 2238 586 59812 100nF 10% 50V

RESISTORS

3449© 4822 051 30101 100Ω 5% 0,06W
3450© 4822 117 12971 15Ω 5% 0,06W
3451© 4822 117 12971 15Ω 5% 0,06W
3452© 4822 051 30101 100Ω 5% 0,06W
3453© 4822 051 30109 10Ω 5% 0,06W

3454© 4822 117 12971 15Ω 5% 0,06W
3455© 4822 051 30102 1kΩ 5% 0,06W
3456© 4822 051 30102 1kΩ 5% 0,06W
3457© 5322 117 13051 680Ω 1% 0,063W
3458© 5322 117 13061 180Ω 1% 0,063W

3459© 4822 051 30221 220Ω 5% 0,06W
3460© 4822 051 30102 1kΩ 5% 0,06W
3461© 4822 051 30479 47Ω 5% 0,06W
3462© 4822 051 30101 100Ω 5% 0,06W
3463© 4822 051 30101 100Ω 5% 0,06W

3464© 4822 051 30103 10kΩ 5% 0,06W
3465© 4822 051 30101 100Ω 5% 0,06W
3466© 4822 051 30471 470Ω 5% 0,06W
3467© 4822 051 30103 10kΩ 5% 0,06W
3468© 4822 051 30103 10kΩ 5% 0,06W

3469© 4822 051 30101 100Ω 5% 0,06W
3470© 4822 117 12971 15Ω 5% 0,06W
3471© 4822 051 30339 33Ω 5% 0,06W
3472© 4822 051 30154 150kΩ 5% 0,06W
3473© 4822 117 13632 100kΩ 1% 0,06W

RESISTORS

3474© 4822 117 12971 15Ω 5% 0,06W
3475© 4822 051 30101 100Ω 5% 0,06W
3476© 4822 051 30101 100Ω 5% 0,06W
3477© 4822 051 30471 470Ω 5% 0,06W
3478© 4822 051 30471 470Ω 5% 0,06W

3479© 4822 051 30471 470Ω 5% 0,06W
3480© 4822 051 30101 100Ω 5% 0,06W
3481© 4822 051 30101 100Ω 5% 0,06W
3482© 4822 051 30471 470Ω 5% 0,06W
3483© 4822 051 30101 100Ω 5% 0,06W

3484© 4822 117 12971 15Ω 5% 0,06W
3486© 4822 051 30101 100Ω 5% 0,06W
3488© 4822 117 13632 100kΩ 1% 0,06W
3489© 4822 051 30103 10kΩ 5% 0,06W
3490© 4822 051 30101 100Ω 5% 0,06W

3491© 4822 051 30479 47Ω 5% 0,06W
3492© 4822 051 30105 1MΩ 5% 0,06W
3493© 4822 051 30103 10kΩ 5% 0,06W
3494© 4822 051 30103 10kΩ 5% 0,06W
3495© 4822 051 30103 10kΩ 5% 0,06W

3497© 4822 051 30103 10kΩ 5% 0,06W
3498© 4822 051 30332 3,3kΩ 5% 0,06W
3499© 4822 051 30103 10kΩ 5% 0,06W
4450© 4822 051 30008 CHIP JUMPER 0603

COILS

1460 4822 242 10989 CER.RES. 16,9MHz
5450© 4822 157 11074 100µH

DIODES

6450© 4822 130 11411 BZX284-C3V3
6451© 4822 130 11366 BZX284-C3V9
7454 4822 130 34174 BZX79-B4V7

TRANSISTORS

7452© 3198 010 42310 BC847BW
7453© 3198 010 42310 BC847BW
7456© 3198 010 42310 BC847BW
7460© 3198 010 42310 BC847BW

INTEGRATED CIRCUITS

7450© not available please order complete MP3 module
7451© not available please order complete MP3 module
7455© 4822 209 17108 LM317LD Voltage Regulator
7457© 9352 456 50115 HC1G04, Inverter
7458© 9322 130 41668 M24C64, EEPROM

3103 308 67020 complete MP3CD2002 Module

MMPWR 100W MODULE

TABLE OF CONTENTS

Module Exploded View	11-1
STK442-110 Internal Block Diagram	11-1
Mains Socket - Layout and Circuit diagram	11-2
Mains Board - Component Layout	11-2
Mains Board - Circuit diagram	11-3
L/R Amp. & Supply Board - Component layout	11-4
L/R Amp. & Supply Board - Circuit diagram (Part 1)	11-5
L/R Amp. & Supply Board - Circuit diagram (Part 2)	11-6
Electrical parts list	11-7

Module Exploded view

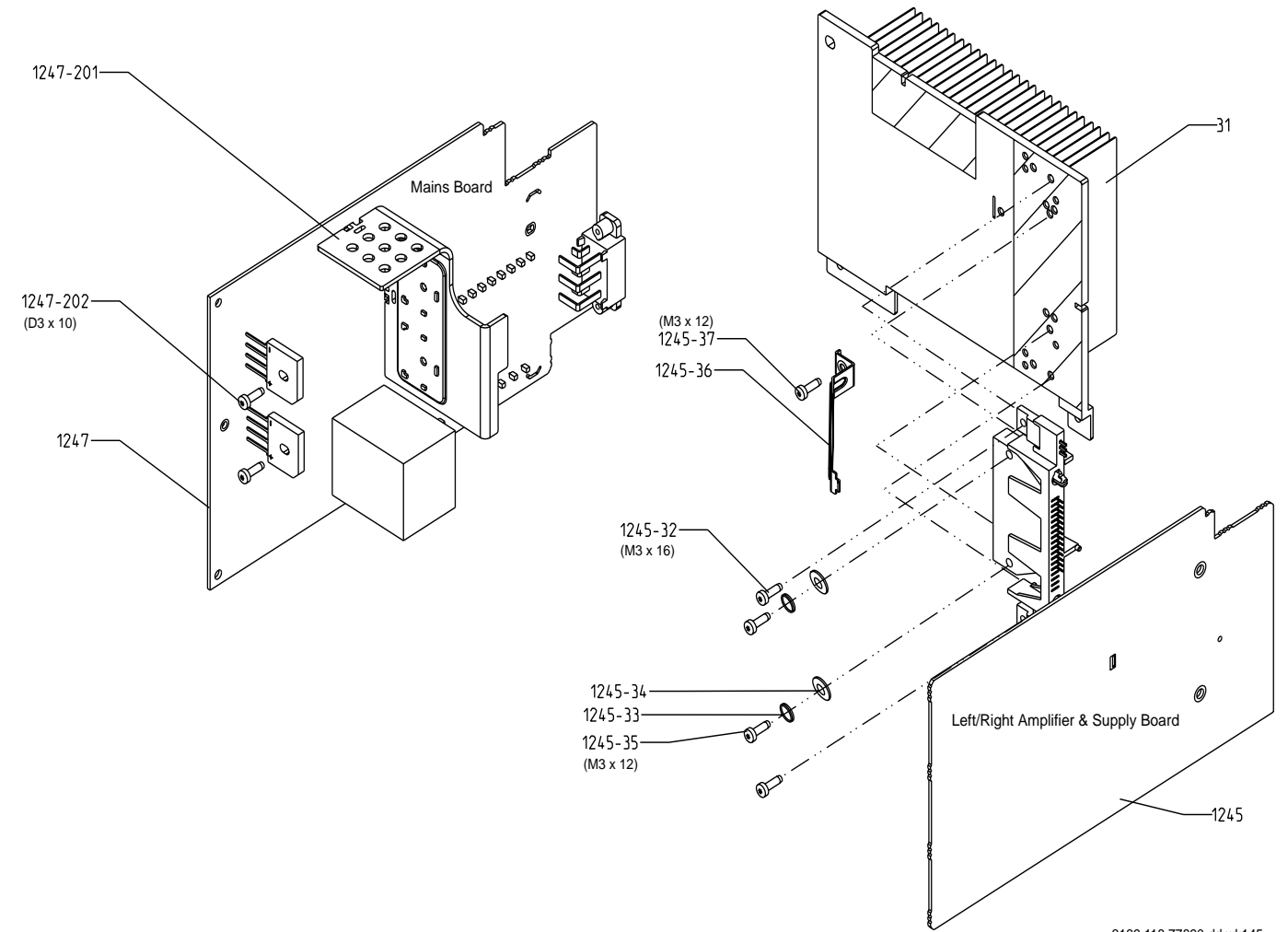

STK442-110 Internal Block diagram

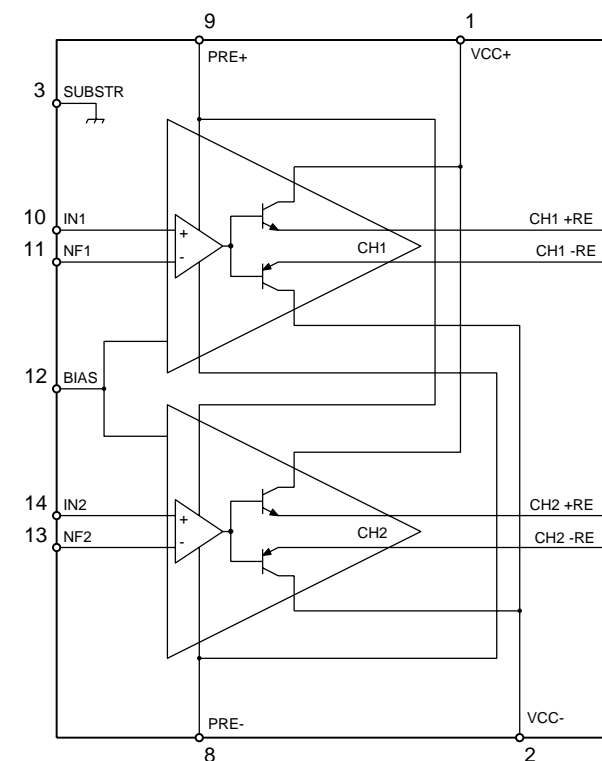

MAINS SOCKET - CIRCUIT DIAGRAM

MAINS BOARD - COPPER SIDE VIEW

1901 B1 5901 A2 8902_A A2 9902 B2
 5900 A2 8901_A B2 9901 A2

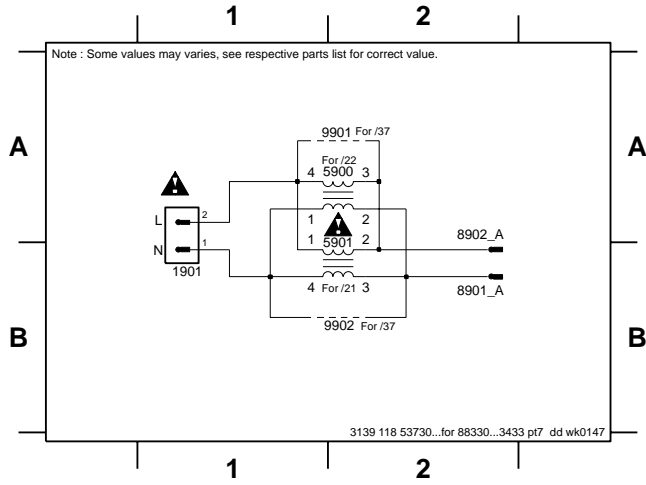

1902 C1	1926 A2	2925 B5	2946 A8	3907 C7	3955 C8	5912 B2	6903 C6	6921 A5	7911 D8	9706 B3	9720 A3	9738 A6	9752 C8	9922 A4
1903 D5	2901 D6	2926 B5	2947 A8	3912 D8	5003 D4	5913 C3	6904 C6	6922 B5	7912 C8	9707 B3	9721 A4	9739 B7	9753 C8	9923 B3
1904 D6	2902 C6	2927 A6	2948 C8	3913 D7	5004 D3	5914 B3	6905 C7	6923 A7	7951 C8	9708 B3	9722 A4	9741 B7	9754 C7	9924 A3
1905 C1	2903 C7	2928 B6	2949 A8	3914 D8	5005 D3	5915 C3	6906 D7	6924 A7	7952 C8	9709 B2	9723 A4	9742 C7	9755 C7	9925 A7
1911 B8	2904 D6	2929 A5	2953 C8	3921 A7	5006 D3	5916 B3	6907 D6	6925 A7	8230 A4	9710 B2	9724 A4	9743 C7	9759 A5	9926 C7
1912 B8	2905 D6	2930 A5	2997 A7	3922 A6	5007 D3	5917 C3	6908 C7	6926 A7	8901 B1	9711 B2	9725 B6	9744 A8	9760 B4	9927 C7
1913 B8	2911 D8	2931 A4	2998 B6	3923 B7	5008 D2	5918 B4	6909 C7	6927 A7	8902 B1	9712 D4	9726 D4	9745 B6	9900 D6	9930 A7
1914 B7	2912 D8	2932 A4	3901 C5	3941 A8	5902 B1	5919 C4	6910 C6	6928 A7	9700 B4	9713 D3	9732 B5	9746 B6	9903 B1	9931 A8
1921 B4	2913 D8	2941 A7	3902 D5	3942 A7	5903 D5	5920 B4	6911 C7	6927 A7	9701 B4	9714 D3	9733 B5	9747 B6	9904 B1	
1922 B4	2921 A5	2942 A7	3903 D7	3951 C8	5905 C6	5921 C4	6915 D8	6928 A7	9702 B4	9715 D3	9734 A5	9748 A6	9907 D5	
1923 B3	2922 A5	2943 A7	3904 D7	3952 C8	5906 B1	5920 D7	6916 D8	6929 A7	9703 B4	9716 D3	9735 A7	9749 B8	9908 D6	
1924 B3	2923 A5	2944 A7	3905 D7	3953 C8	5910 B2	6901 D6	6917 D8	7901 D7	9704 B3	9718 D2	9736 B6	9750 B7	9910 C7	
1925 B2	2924 B5	2945 A8	3906 D7	3954 C8	5911 C2	6902 D6	6918 D8	7902 D7	9705 B3	9719 D2	9737 B5	9751 B7	9921 B4	

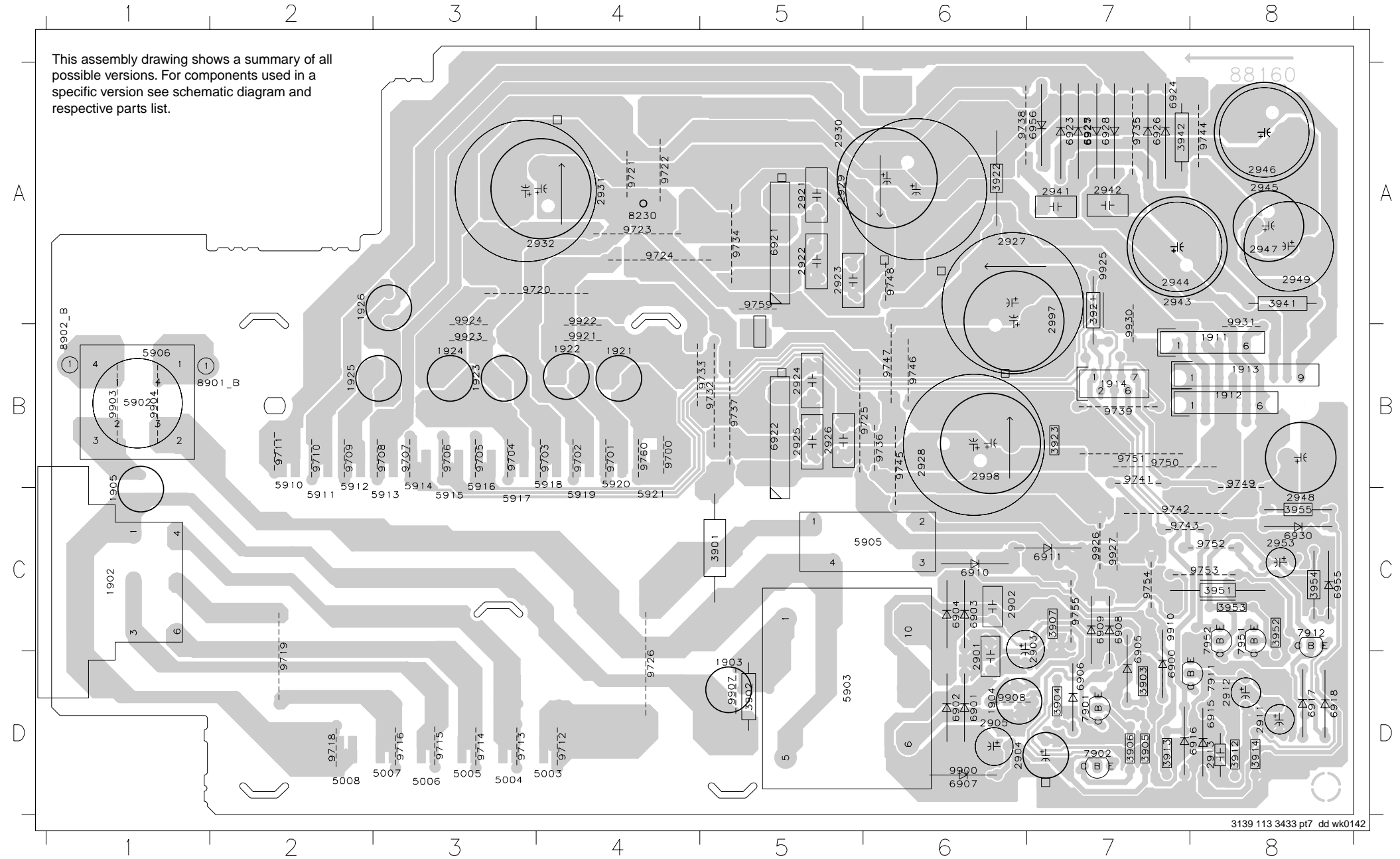

MAINS SOCKET - COPPER SIDE VIEW

1901 A1 5901 A2 8902_A A3 9902 A2
 5900 A2 8901_A A3 9901-A2

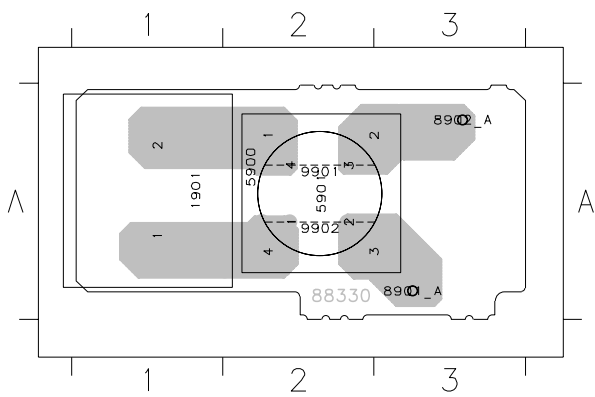

MAINS BOARD - CIRCUIT DIAGRAM

1902 A3	1912 A10	1923 A6	2902 D3	2912 F3	2924 A8	2929 B9	2942 C7	2947 D7	2998 B8	3905 D4	3914 E5	3942 E7	3955 F1	6900 D3	6905 E1	6910 C3	6918 E6	6925 C7	6955 D10	7912 D5	8902_B B1	9908 D2	9924 B6	9931 B10
1903 D1	1913 A10	1924 B6	2903 E3	2913 F3	2925 A8	2930 B9	2943 C8	2948 F4	3901 E1	3906 D4	3921 B6	3951 C8	5902 B1	6901 D2	6906 E2	6911 C3	6921 A7	6926 C7	6956 D6	7951 C9	9900 E4	9910 D4	9925 B6	
1904 D2	1914 E7	1925 C6	2904 E3	2914 A7	2926 A8	2931 B9	2944 C8	2949 D7	3902 D1	3907 E2	3922 B7	3952 D9	5903 D1	6902 D2	6907 E4	6915 F2	6922 A8	6927 C7	7901 D4	7952 C10	9903 A1	9926 B7		
1905 B2	1921 A6	1926 C6	2905 E3	2922 A7	2927 B8	2932 B9	2945 D7	2953 D10	3903 E2	3912 F3	3923 B8	3953 D9	5905 B3	6903 D3	6908 D4	6916 F4	6923 C6	6928 C7	7902 E4	8230 F8	9904 B1	9922 A6	9927 B7	
1911 A10	1922 A6	2901 D2	2911 F2	2923 A8	2928 B9	2941 C6	2946 D7	2997 B8	3904 E2	3913 F3	3941 D8	3954 D10	5906 A1	6904 D3	6909 E4	6917 E6	6924 C6	6928 F1	7911 F3	8901_B B1	9907 D1	9923 B6	9930 A10	

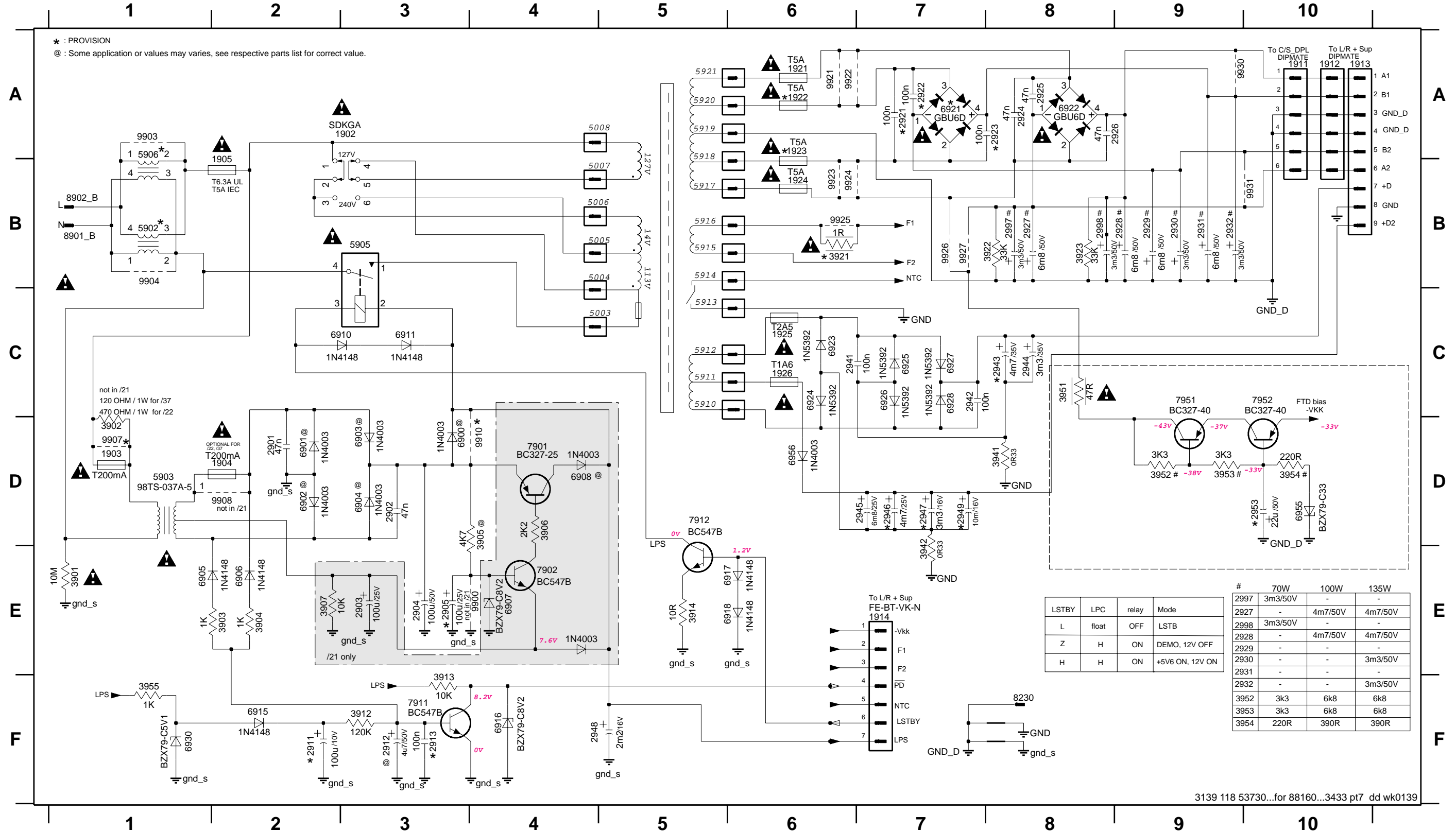

LEFT/RIGHT AMPLIFIER & SUPPLY BOARD - COPPER SIDE VIEW

1250 B2	2261 B1	2352 B3	3259 C5	3289 C2	3337 A3	3366 B5	6251 A3	7253 A4	9253 C3	9468 B4	9497 B2	9528 B1
1251 C2	2262 A1	2353 C3	3260 C5	3290 A5	3338 A3	3367 B4	6252 C5	7254 C5	9320 B3	9469 B3	9498 A3	9529 A2
1252 B2	2263 A1	2355 B4	3261 C5	3292 C3	3339 A3	3368 B6	6253 C3	7255 C4	9321 A3	9470 C4	9499 A2	9530 A2
1259 A2	2265 C2	2360 C6	3262 C4	3295 A2	3341 A4	3369 A6	6254 C3	7256 C4	9323 B4	9471 C4	9500 B2	9531 B2
1260 A2	2300 C5	2361 C6	3263 C3	3300 C5	3342 A6	3370 A6	6256 C1	7257 C5	9329 B4	9472 B5	9501 B3	9532 A2
1261 A2	2320 C1	2362 C6	3264 C5	3301 C5	3343 A5	3371 C6	6257 C1	7259 C2	9330 A5	9473 C4	9502 B2	9533 C2
1262 A2	2321 C1	2363 A6	3265 A2	3302 C4	3344 B4	3372 C6	6258 C3	7260 A1	9331 A5	9474 B4	9503 A3	9534 C2
1263 A2	2322 C1	2364 B6	3268 C2	3303 C5	3345 B3	3373 C6	6259 A1	7261 A1	9333 A5	9475 C4	9504 A2	9535 C2
1264 A2	2323 B1	2365 B6	3269 C2	3304 C4	3346 B3	3374 A6	6260 A1	7262 A1	9341 B4	9476 B2	9505 A2	9536 C2
1280 C2	2324 A3	2366 C6	3270 C2	3305 C4	3347 B4	3375 A6	6261 A2	7263 A1	9342 C6	9477 B4	9506 A2	9537 B1
1300 C3	2325 A6	2367 C6	3271 C2	3306 C4	3348 B4	3376 B6	6262 A2	7264 C2	9343 B6	9478 B4	9507 B2	9538 C2
1321 B6	2328 A4	2368 B6	3272 C2	3320 C1	3349 C5	3377 B3	6263 A1	7265 C2	9355 B4	9480 B3	9508 B2	9540 A2
1322_A C5	2329 A3	2369 B6	3273 A1	3321 C1	3350 C5	3378 B3	6264 C2	7300 C4	9356 B5	9481 B3	9509 A4	9541 A2
1322_B B2	2330 A5	2370 B5	3274 A1	3322 C1	3351 B6	3379 B4	6265 A1	7320 C1	9360 B6	9482 B3	9510 A2	9960 A5
1323_A C4	2331 A4	2371 B5	3275 A1	3323 C1	3352 B5	3380 B4	6320 C1	7321 B1	9361 A6	9483 C2	9512 A1	9961 B4
1323_B B2	2332 A3	2372 A4	3276 A1	3324 C1	3353 C5	3381 C5	6321 C1	7322 B1	9362 B6	9484 C2	9513 A6	9962 A3
1330_A5	2333 A4	2375 C6	3277 B1	3325 B1	3354 B5	3382 A6	6322 C1	7323 B1	9363 B6	9485 B3	9514 A1	
2250 A4	2334 A4	2390 A3	3278 A1	3326 B1	3355 B5	3392 A5	6323 B1	7324 C1	9452 C6	9486 B3	9515 A1	
2251 A4	2335 A5	2391 A5	3279 A3	3327 B1	3356 B4	3393 A5	6324 C5	7325 C1	9453 B6	9487 B3	9516 B1	
2252 A4	2336 A4	3250 A5	3280 A2	3328 B1	3357 B4	3395 A5	6330 C6	7326 A5	9455 A5	9488 B3	9517 B1	
2253 A4	2339 A6	3251 A5	3281 A1	3329 C1	3358 B4	3400 A3	6331 A6	7327 B5	9456 C6	9489 B3	9519 A2	
2254 C3	2340 B4	3252 A5	3282 A1	3330 C1	3359 B6	3401 B3	6332 B4	7328 B5	9457 B5	9490 B2	9520 B1	
2255 C3	2341 A3	3253 A5	3283 A1	3331 C1	3360 B6	3402 A2	6360 A6	7329 B4	9458 B4	9491 A3	9521 B2	
2256 C3	2342 A3	3254 A5	3284 B1	3332 C1	3361 A4	3403 A3	7240 A3	7330 A5	9460 B4	9492 B2	9522 B2	
2257 C4	2343 B3	3255 A4	3285 A1	3333 C1	3362 A5	3404 A4	7241 A3	8240 B2	9462 A4	9493 A3	9524 B1	
2258 C4	2344 B4	3256 A4	3286 C2	3334 B3	3363 B5	5300 C6	7250 A5	9250 C3	9465 B5	9494 A3	9525 B3	
2259 C5	2345 C1	3257 A3	3287 C2	3335 A3	3364 B5	5301 A6	7251 A4	9251 C3	9466 B4	9495 B2	9526 C1	
2260 A1	2350 C4	3258 C5	3288 C2	3336 A4	3365 B5	6250 A3	7252 A5	9252 C3	9467 A4	9496 A3	9527 C1	

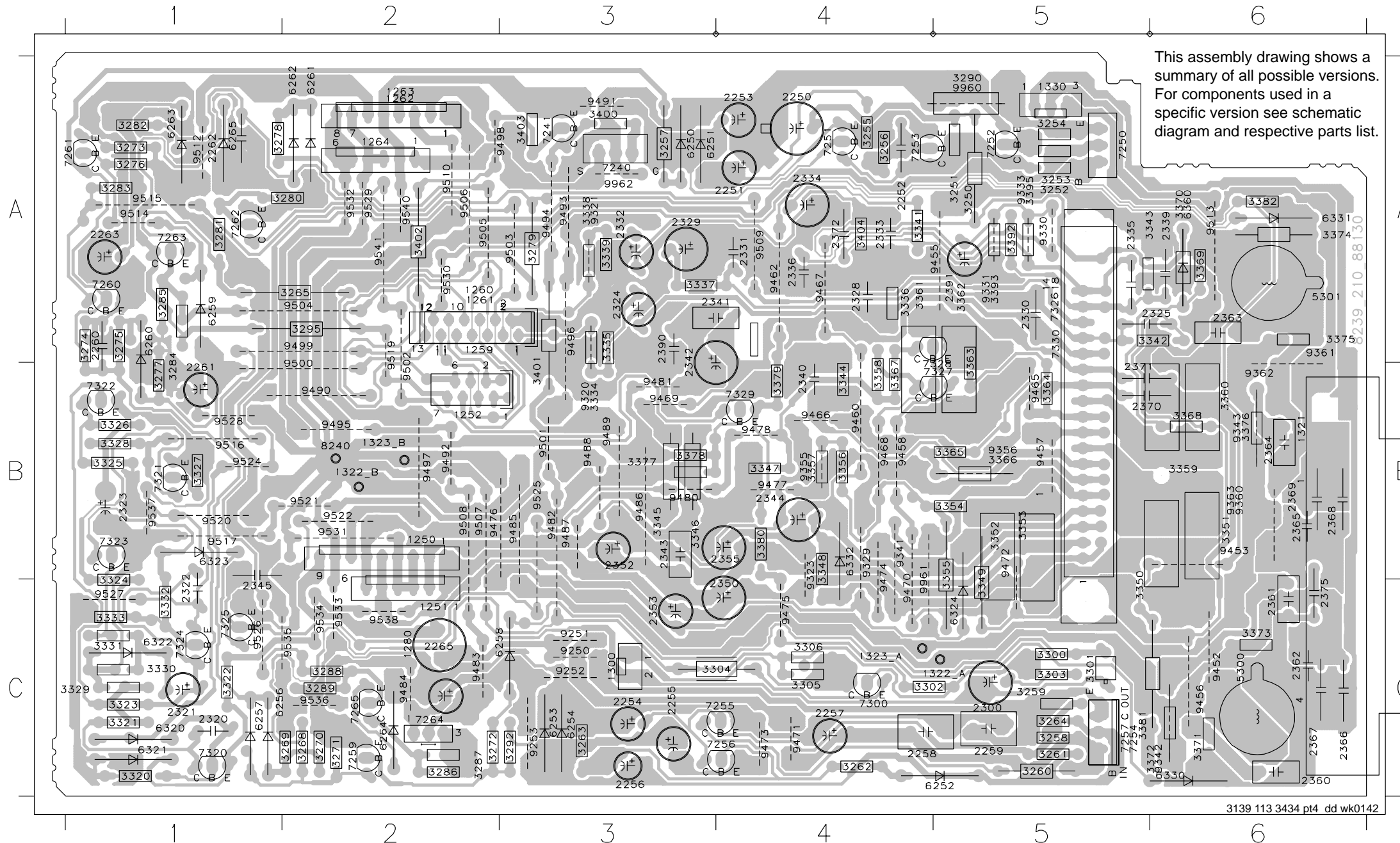

LEFT/RIGHT AMPLIFIER & SUPPLY BOARD - CIRCUIT DIAGRAM (PART 1)

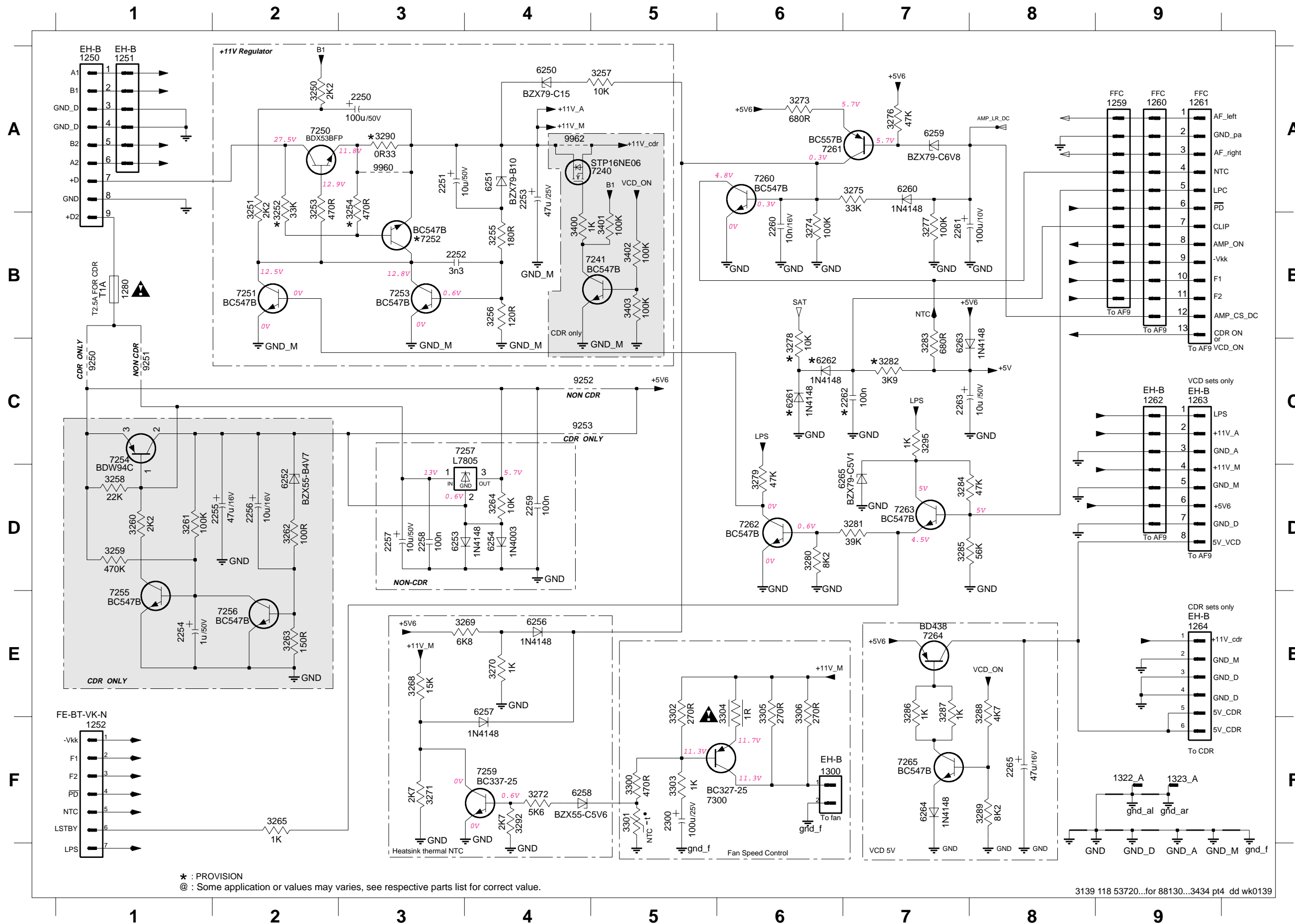

- 1250 A1
- 1251 A1
- 1252 F1
- 1259 A9
- 1260 A9
- 1261 A9
- 1262 C9
- 1263 C9
- 1264 E9
- 1280 B1
- 1300 F6
- 1322_A F9
- 1323_A F9
- 2250 A3
- 2251 A3
- 2252 B3
- 2253 A4
- 2254 E1
- 2255 D1
- 2256 D2
- 2257 D3
- 2258 D3
- 2259 D4
- 2260 B6
- 2261 B7
- 2262 C7
- 2263 C7
- 2265 F8
- 2300 F5
- 3250 A2
- 3251 A2
- 3252 A2
- 3253 A2
- 3254 A3
- 3255 B4
- 3256 B4
- 3257 A5
- 3258 D1
- 3259 D1
- 3260 D1
- 3261 D1
- 3262 D2
- 3263 E2
- 3264 D4
- 3265 F2
- 3268 E3
- 3269 E4
- 3270 E4
- 3271 F3
- 3272 F4
- 3273 A6
- 3274 B6
- 3275 A7
- 3276 A7
- 3277 B7
- 3278 C6
- 3279 D6
- 3280 D6
- 3281 D7
- 3282 C7
- 3283 C7
- 3284 D7
- 3285 D7
- 3286 E7
- 3287 E7
- 3288 E8
- 3289 F8
- 3290 A3
- 3292 F4
- 3295 C7
- 3300 F5
- 3301 F5
- 3302 E5
- 3303 F5
- 3304 E6
- 3305 E6
- 3306 E6
- 3400 B4
- 3401 B5
- 3402 B5
- 3403 B5
- 6250 A4
- 6251 A4
- 6252 D2
- 6253 D3
- 6254 D4
- 6256 E4
- 6257 E4
- 6258 F4
- 6259 A7
- 6260 A7
- 6261 C6
- 6262 C6
- 6263 C7
- 6264 F7
- 6265 D6
- 7240 A5
- 7241 B5
- 7250 A2
- 7251 B2
- 7252 B3
- 7253 B3
- 7254 C1
- 7255 E1
- 7256 E2
- 7257 C4
- 7259 F4
- 7260 A6
- 7261 A6
- 7262 D6
- 7263 D7
- 7264 E7
- 7265 F8
- 7300 F5
- 9250 C1
- 9251 C1
- 9252 C4
- 9253 C4
- 9254 A3
- 9255 A3
- 9960 A3
- 9962 A4

* : PROVISION
 @ : Some application or values may varies, see respective parts list for correct value.

LEFT/RIGHT AMPLIFIER & SUPPLY BOARD - CIRCUIT DIAGRAM (PART 2)

1321-A C11	2323 D3	2333 B3	2343 E5	2361 B9	2369 C11	3321 C1	3329 D1	3337 B4	3346 E6	3354 B7	3362 C7	3370 A8	3378 E9	3404 B3	6330 B10	7324 E1	9321 B1	9343 C9
1321-B A11	2324 A2	2334 C3	2344 E6	2362 A11	2370 D5	3322 C2	3330 E1	3338 B1	3347 E4	3355 B7	3363 C7	3371 B9	3379 D10	5300 A9	6331 C10	7325 E4	9323 A10	9355 C8
1322_B B11	2325 A4	2335 D4	2345 E4	2363 C9	2371 D5	3323 D1	3331 E2	3339 B2	3348 A8	3356 B8	3364 C7	3372 B9	3380 D10	5301 C9	6332 A8	7327 B8	9329 E10	9356 D7
1323_B D11	2328 A3	2336 D4	2350 A7	2364 C9	2372 C3	3324 D2	3332 E2	3341 C3	3349 E8	3357 C8	3365 D8	3373 B10	3381 A9	6320 C1	6360 A8	7328 C8	9330 B3	9360 C10
1330 B11	2329 B4	2339 D4	2352 A7	2365 C11	2375 A10	3325 D3	3333 E2	3342 A4	3350 B7	3358 C8	3366 D8	3374 C9	3382 A10	6321 C1	7320 C1	7329 E10	9331 C4	9361 C10
2320 C1	2330 A4	2340 A3	2353 E7	2366 A10	2390 A1	3326 D3	3334 A1	3343 D4	3351 B7	3359 C7	3367 D8	3375 C10	3392 B3	6322 E1	7321 C2	7330 B6	9333 C4	9362 C10
2321 E1	2331 B4	2341 A5	2355 E7	2367 A10	2391 C4	3327 D2	3335 A2	3344 A3	3352 B7	3360 C7	3368 A8	3376 C9	3393 C4	6323 E3	7322 D3	8240 A2	9341 A6	9363 C10
2322 E2	2332 B2	2342 A6	2360 B9	2368 C11	3320 C1	3328 D3	3336 A3	3345 A6	3353 B7	3361 C7	3369 A8	3377 E9	3395 C4	6324 E8	7323 E2	9320 A1	9342 B9	9961 A6

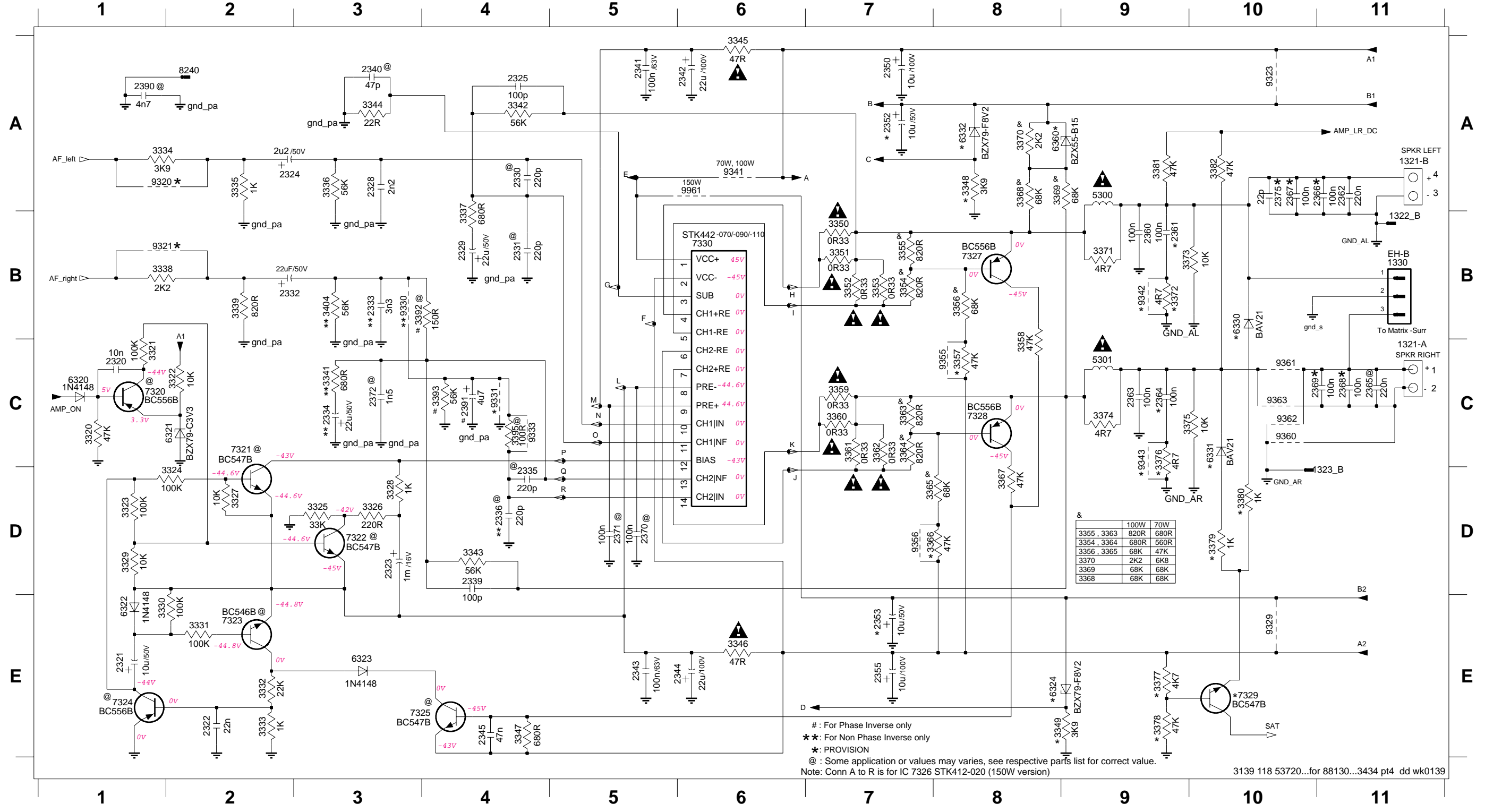

: For Phase Inverse only
 * : For Non Phase Inverse only
 * : PROVISION
 @ : Some application or values may varies, see respective parts list for correct value.
 Note: Conn A to R is for IC 7326 STK412-020 (150W version)

ELECTRICAL PARTS LIST - MAINS BOARD

MISCELLANEOUS

1901	4822 265 31015	△	Mains Socket
1901	2422 030 00328	△	Mains Socket /37
1902	2422 129 16478	△	Voltage Selector /21/21M
1903	4822 071 52001	△	Fuse T200mA 250V /21/21M
1904	4822 071 52001	△	Fuse T200mA 250V /21/21M
1905	2422 086 10963	△	Fuse T5A 250V
1905	4822 252 51123	△	Fuse T6,3A 250V /37
1914	4822 267 10953		Flex Socket 7 Pin Vert.
1921	4822 071 55002	△	Fuse T5A 250V
1924	4822 071 55002	△	Fuse T5A 250V
1925	4822 071 52502	△	Fuse T2,5A 250V
1926	4822 071 51602	△	Fuse T1,6A 250V

CAPACITORS

2901	4822 121 43526		47nF 5% 250V
2902	4822 121 43526		47nF 5% 250V
2903	4822 124 40207		100µF 20% 25V /21/21M
2904	4822 124 40255		100µF 20% 63V
2912	4822 124 21913		1µF 20% 63V
2924	4822 121 43526		47nF 5% 250V
2925	4822 121 43526		47nF 5% 250V
2926	4822 121 43526		47nF 5% 250V
2927	4822 124 80415		4700µF 20% 50V
2928	4822 124 80415		4700µF 20% 50V
2941	5322 121 42386		100nF 5% 63V
2942	5322 121 42386		100nF 5% 63V
2944	4822 124 42367		3300µF 20% 35V
2945	4822 124 12328		6800µF 25V
2948	4822 123 14025		2200µF 20% 16V

RESISTORS

3901	4822 053 21106	△	10M 5% 0,5W /37
3902	4822 053 10471		470R 5% PR01 /22/30/34
3902	4822 053 10121		120R 5% PR01 /37
3903	4822 050 11002		1k 1% 0,4W
3904	4822 050 11002		1k 1% 0,4W
3905	4822 116 52244		15k 5% 0,5W
3905	4822 116 52283		4k7 5% 0,5W /21/21M
3906	4822 116 52256		2k2 5% 0,5W /21/21M
3907	4822 050 21003		10k 1% 0,6W /21/21M
3912	4822 116 52234		100k 5% 0,5W
3913	4822 050 21003		10k 1% 0,6W
3914	4822 116 52176		10R 5% 0,5W
3922	4822 050 23303		33k 1% 0,6W
3923	4822 050 23303		33k 1% 0,6W
3941	4822 117 11342		0R33 5% 2W
3942	4822 117 11342		0R33 5% 2W
3951	4822 052 10479	△	47R 5% 0,33W
3952	4822 116 83961		6k8 5%
3953	4822 116 83961		6k8 5%
3954	4822 116 83881		390R 5% 0,5W
3955	4822 050 11002		1k 1% 0,4W

COILS & FILTERS

5900	4822 157 11832	△	Mains Filter 400µH 3A /22/30/34
5901	4822 157 11628	△	Mains Choke /21/21M
5903	3103 308 30600	△	Standby Transformer /21/21M
5903	3103 308 30610	△	Standby Transformer /22/30/34
5903	3103 308 30800	△	Standby Transformer /37
5905	4822 280 10382	△	Relay 1P 9V 10/80A SDT-SS

DIODES

6900	4822 130 31878		1N4003G not for /21/21M
6901	4822 130 31878		1N4003G
6901	5322 130 81917		SB140 /21/21M
6902	5322 130 81917		SB140 /21/21M
6902	4822 130 31878		1N4003G
6903	4822 130 31878		1N4003G
6903	5322 130 81917		SB140 /21/21M
6904	5322 130 81917		SB140 /21/21M
6904	4822 130 31878		1N4003G
6905	4822 130 30621		1N4148
6906	4822 130 30621		1N4148
6907	4822 130 34382		BZX79-B8V2 /21/21M
6908	5322 130 81917		SB140 /21/21M
6909	4822 130 31878		1N4003G /21/21M
6910	4822 130 30621		1N4148
6911	4822 130 30621		1N4148
6915	4822 130 30621		1N4148
6916	4822 130 34382		BZX79-B8V2
6917	4822 130 30621		1N4148
6918	4822 130 30621		1N4148
6922	4822 130 10944		GBU6D
6923	4822 130 31878		1N5392
6924	4822 130 31878		1N5392
6925	4822 130 31878		1N5392
6926	4822 130 31878		1N5392
6927	4822 130 31878		1N5392
6928	4822 130 31878		1N5392
6930	4822 130 34233		BZX79-B5V1
6955	4822 130 34142		BZX79-B33
6956	4822 130 31878		1N4003G

TRANSISTOR & INTEGRATED CIRCUITS

7901	4822 130 41246		BC327-25 /21/21M
7902	4822 130 40959		BC547B /21/21M
7911	4822 130 40959		BC547B
7912	4822 130 40959		BC547B
7951	4822 130 41327		BC327-40
7952	4822 130 41327		BC327-40

Note: Only the parts mentioned in this list are normal service spare parts.

ELECTRICAL PARTS LIST - LEFT/RIGHT AMPLIFIER & SUPPLY BOARD

MISCELLANEOUS

28	3139 114 70800		Holder STK IC
1252	4822 267 10953		Flex Socket 7 Pin Vert.
1259	4822 267 11039		Flex Socket 11 Pin Vert.
1280	4822 071 51002	△	Fuse T1A 250V
1321	4822 267 31176		Loudspeaker Socket 4P

CAPACITORS

2250	4822 124 40255		100µF 20% 63V
2251	4822 124 40248		10µF 20% 63V
2252	4822 122 10577		3,3nF 10% 16V
2253	4822 124 40433		47µF 20% 25V
2257	4822 124 40248		10µF 20% 63V
2258	5322 121 42386		100nF 5% 63V
2259	5322 121 42386		100nF 5% 63V
2260	4822 121 51387		10nF 20% 16V
2261	4822 124 41584		100µF 20% 10V
2263	4822 124 40248		10µF 20% 63V
2300	4822 124 40207		100µF 20% 25V
2320	4822 121 43693		10nF 100V
2321	4822 124 22652		2,2µF 20% 50V
2322	4822 121 41856		22nF 5% 250V
2323	4822 124 81144		1000µF 16V
2324	4822 124 22652		2,2µF 20% 50V
2325	4822 122 33195		100pF 10% 50V
2328	5322 122 32818		2,2nF 10% 100V /21/21M
2329	4822 124 81151		22µF 50V
2330	4822 126 14316		680pF 10% 50V /21/21M
2330	4822 122 33519		470pF 10% 50V
2331	4822 126 13461		680pF 10% 50V /21/21M
2332	4822 124 81151		22µF 50V
2335	4822 126 14316		680pF 10% 50V /21/21M
2335	4822 122 33519		470pF 10% 50V
2336	4822 126 13461		680pF 10% 50V /21/21M
2339	4822 122 33195		100pF 10% 50V
2340	4822 126 12726		47pF 50V not for /21/21M
2341	5322 121 42386		100nF 5% 63V
2342	4822 124 40764		22µF 100V
2343	5322 121 42386		100nF 5% 63V
2344	4822 124 40764		22µF 100V
2345	4822 126 12785		47nF 50V
2350	5322 124 40641		10µF 20% 100V
2355	5322 124 40641		10µF 20% 100V
2360	5322 121 42386		100nF 5% 63V
2362	4822 121 42868		220nF 5% 50V
2363	5322 121 42386		100nF 5% 63V
2365	2020 308 90054		270nF 5% 50V /21/21M
2365	4822 121 42868		220nF 5% 50V
2370	2020 561 90365		100nF +80/-20% 50V not for /21/21M
2371	2020 561 90365		100nF +80/-20% 50V not for /21/21M
2372	4822 126 12878		1,5nF 10% 16V not for /21/21M
2390	4822 122 33449		47nF 30% 50V /21/21M
2390	5322 122 32261		4,7nF 50V

2391	4822 124 40769		4,7µF 20% 100V
------	----------------	--	----------------

RESISTORS

3250	4822 116 52256		2k2 5% 0,5W
3251	4822 116 52256		2k2 5% 0,5W
3253	4822 116 83883		470R 5% 0,5W
3255	4822 116 52213		180R 5% 0,5W
3256	4822 116 52206		120R 5% 0,5W
3257	4822 050 21003		10k 1% 0,6W
3264	4822 050 21003		10k 1% 0,6W
3265	4822 050 11002		1k 1% 0,4W
3268	4822 116 52244		15k 5% 0,5W
3269	4822 116 83961		6k8 5%
3270	4822 050 11002		1k 1% 0,4W
3271	4822 116 52263		2k7 5% 0,5W
3272	4822 116 52289		5k6 5% 0,5W
3273	4822 116 52228		680R 5% 0,5W
3274	4822 116 52234		100k 5% 0,5W
3275	4822 050 23303		33k 1% 0,6W
3276	4822 116 83884		47k 5% 0,5W
3277	4822 116 52234		100k 5% 0,5W
3279	4822 116 83884		47k 5% 0,5W
3280	4822 116 52303		8k2 5% 0,5W
3281	4822 116 83882		39k 5% 0,5W
3283	4822 116 52228		680R 5% 0,5W
3284	4822 116 83884		47k 5% 0,5W
3285	4822 116 52291		56k 5% 0,5W
3292	4822 116 52263		2k7 5% 0,5W
3295	4822 050 11002		1k 1% 0,4W
3300	4822 116 83883		470R 5% 0,5W
3301	4822 117 12063		NTC DC 5W 10K 5%
3302	4822 116 83876		270R 5% 0,5W
3303	4822 050 11002		1k 1% 0,4W
3304	4822 052 10108	△	1R 5% 0,33W
3305	4822 116 83876		270R 5% 0,5W
3306	4822 116 83876		270R 5% 0,5W
3320	4822 116 83884		47k 5% 0,5W
3321	4822 116 52234		100k 5% 0,5W
3322	4822 050 21003		10k 1% 0,6W
3324	4822 116 52234		100k 5% 0,5W
3325	4822 050 23303		33k 1% 0,6W
3326	4822 116 83872		220R 5% 0,5W
3327	4822 050 21003		10k 1% 0,6W
3328	4822 050 11002		1k 1% 0,4W
3329	4822 050 21003		10k 1% 0,6W
3330	4822 116 52234		100k 5% 0,5W
3331	4822 116 52234		100k 5% 0,5W
3332	4822 116 52257		22k 5% 0,5W
3333	4822 050 11002		1k 1% 0,4W
3334	4822 116 52276		3k9 5% 0,5W
3335	4822 050 11002		1k 1% 0,4W
3336	4822 116 52291		56k 5% 0,5W

ELECTRICAL PARTS LIST - LEFT/RIGHT AMPLIFIER & SUPPLY BOARD**RESISTORS**

3337	4822 116 52228	680R 5% 0,5W
3338	4822 116 52256	2k2 5% 0,5W
3339	4822 116 52231	820R 5% 0,5W
3342	4822 116 52291	56k 5% 0,5W
3343	4822 116 52291	56k 5% 0,5W
3344	4822 116 52186	22R 5% 0,5W
3345	3198 012 14790 Δ	RST POW 47R 5% 1W
3346	3198 012 14790 Δ	RST POW 47R 5% 1W
3347	4822 116 52228	680R 5% 0,5W
3350	2322 194 96001 Δ	RST MFLM 0R33 5% PR02
3351	2322 194 96001 Δ	RST MFLM 0R33 5% PR02
3352	2322 194 96001 Δ	RST MFLM 0R33 5% PR02
3353	2322 194 96001 Δ	RST MFLM 0R33 5% PR02
3354	4822 116 52228	680R 5% 0,5W
3355	4822 116 52231	820R 5% 0,5W
3356	4822 116 52297	68k 5% 0,5W
3358	4822 116 83884	47k 5% 0,5W
3359	2322 194 96001 Δ	RST MFLM 0R33 5% PR02
3360	2322 194 96001 Δ	RST MFLM 0R33 5% PR02
3361	2322 194 96001 Δ	RST MFLM 0R33 5% PR02
3362	2322 194 96001 Δ	RST MFLM 0R33 5% PR02
3363	4822 116 52231	820R 5% 0,5W
3364	4822 116 52228	680R 5% 0,5W
3365	4822 116 52297	68k 5% 0,5W
3367	4822 116 83884	47k 5% 0,5W
3368	4822 116 52297	68k 5% 0,5W
3369	4822 116 52297	68k 5% 0,5W
3370	4822 116 52256	2k2 5% 0,5W
3371	4822 050 24708	4R7 1% 0,6W
3373	4822 050 21003	10k 1% 0,6W
3374	4822 050 24708	4R7 1% 0,6W
3375	4822 050 21003	10k 1% 0,6W
3381	4822 116 83884	47k 5% 0,5W
3382	4822 116 83884	47k 5% 0,5W
3392	4822 116 52175	100R 5% 0,5W
3393	4822 116 52291	56k 5% 0,5W
3395	4822 116 52175	100R 5% 0,5W not for /21/21M

COILS & FILTERS

5300	4822 157 70599 Δ	Ind. Fixed Bead EMI
5301	4822 157 70599 Δ	Ind. Fixed Bead EMI

DIODES

6250	4822 130 34281	BZX79-B15
6251	4822 130 61219	BZX79-B10
6253	4822 130 30621	1N4148
6254	4822 130 31878	1N4003G
6256	4822 130 30621	1N4148
6257	4822 130 30621	1N4148
6258	4822 130 34173	BZX79-B5V6
6259	4822 130 34278	BZX79-B6V8
6260	4822 130 30621	1N4148

6263	4822 130 30621	1N4148
6265	4822 130 34233	BZX79-B5V1
6320	4822 130 30621	1N4148
6321	5322 130 31504	BZX79-B3V3
6322	4822 130 30621	1N4148
6323	4822 130 30621	1N4148

TRANSISTORS & INTEGRATED CIRCUITS

7250	9322 139 23687	BDX53BFP
7251	4822 130 40959	BC547B
7253	4822 130 40959	BC547B
7257	4822 209 31841	L7805CP
7259	4822 130 40981	BC337-25
7260	4822 130 40959	BC547B
7261	4822 130 44568	BC557B
7262	4822 130 40959	BC547B
7263	4822 130 40959	BC547B
7300	4822 130 41246	BC327-25
7320	4822 130 44568	BC557B
7321	4822 130 40959	BC547B
7322	4822 130 40959	BC547B
7323	4822 130 40959	BC547B
7324	4822 130 41691	BC556B
7325	4822 130 40959	BC547B
7327	4822 130 41691	BC556B
7328	4822 130 41691	BC556B
7330	9322 160 21682	STK442-110

Note: Only the parts mentioned in this list are normal service spare parts.

BRIEF INTRODUCTION OF THE AF9 BOARD

AF9 BOARD

TABLE OF CONTENTS

Brief Introduction of the AF9 Board 12-1
 Variation Table 12-1
 Chip layout Main part 12-2
 Component Main part 12-3
 Source Selection and Sound Processing Circuit 12-4
 Headphone Amplifier & I²C Expander Circuit 12-5
 Digital Out and Interconnection Circuit 12-6
 Video Out Part - Layouts & Circuit diagram 12-7
 Electrical parts list 12-7

The AF9 Board consists of the following features :

- a. TDA7468D
 TDA7468D (7501) provides the basic sound processing - loudness, bass, treble, volume & mute controls and source selection - TUNER, TAPE, CD & AUX including Mic mixing for the set.
 Sound features such as ALC, DBB, DSC and IS are controlled by the microprocessor IC on the Front Board via I²C Bus.
 Undesirable noise during source switching are muted off by via the software of the microprocessor IC on the Front Board.
- b. MIC MIXING
 Simple Mic mixing is provided by pin 2 of TDA7468D. During Mic mixed a 1nF capacitor is connected across this pin to ground instead of a chip connector(0R).
- c. DOLBY PRO LOGIC (DPL) INTERFACE
 The AF9 Board has provisions to cater for DPL. External DPL Board would be required.
- d. LINE OUT
 Line out cinch socket (1504) is catered including transistors muting circuitry.
- e. SUB-WOOFER OUT
 Sub-woofer out cinch socket (691) for connection to active sub-woofer speaker is catered.
- f. INCREDIBLE SURROUND (IS)
 The AF9 provides 2 possible IS namely:
 - a) Simple IS using TDA7468D with addition of passive network.
 - b) Full IS using transistor circuitry to create phase shifting and spatial effect.
- g. HEADPHONE AMPLIFIER
 Headphone amplifier NJM4556AM (7601) is provided after the Sound processor (7501) to drive 32 ohm to 1kohm headphone.
- h. M62320FP
 The M62320FP (7403) I²C Expander provides additional controls required.
- i. CD STANDBY CONTROL
 Transistors 7401 & 7402 ensures the +5V_CD supply is switched only during CD mode.
- j. CD DIGITAL OUT
 CD Digital out cinch socket (1801) for connection to external digital audio decoders.

VARIATION TABLE:

Type /Versions:	FWM390							
	/21	/22	/25	/30				
Features:								
Line In	x	x	x	x				
Line Out	-	-	-	-				
Sub-woofer Out	-	-	-	-				
Digital Out	-	-	-	-				
Video Out	-	-	-	-				
Mic mix / Mic Detect	-	-	-	-				
Simple IS	x	x	x	x				
Full IS	-	-	-	-				
Dolby ProLogic (DPL)	-	-	-	-				
Voice Control (VC)	-	-	-	-				

COMPONENT LAYOUT

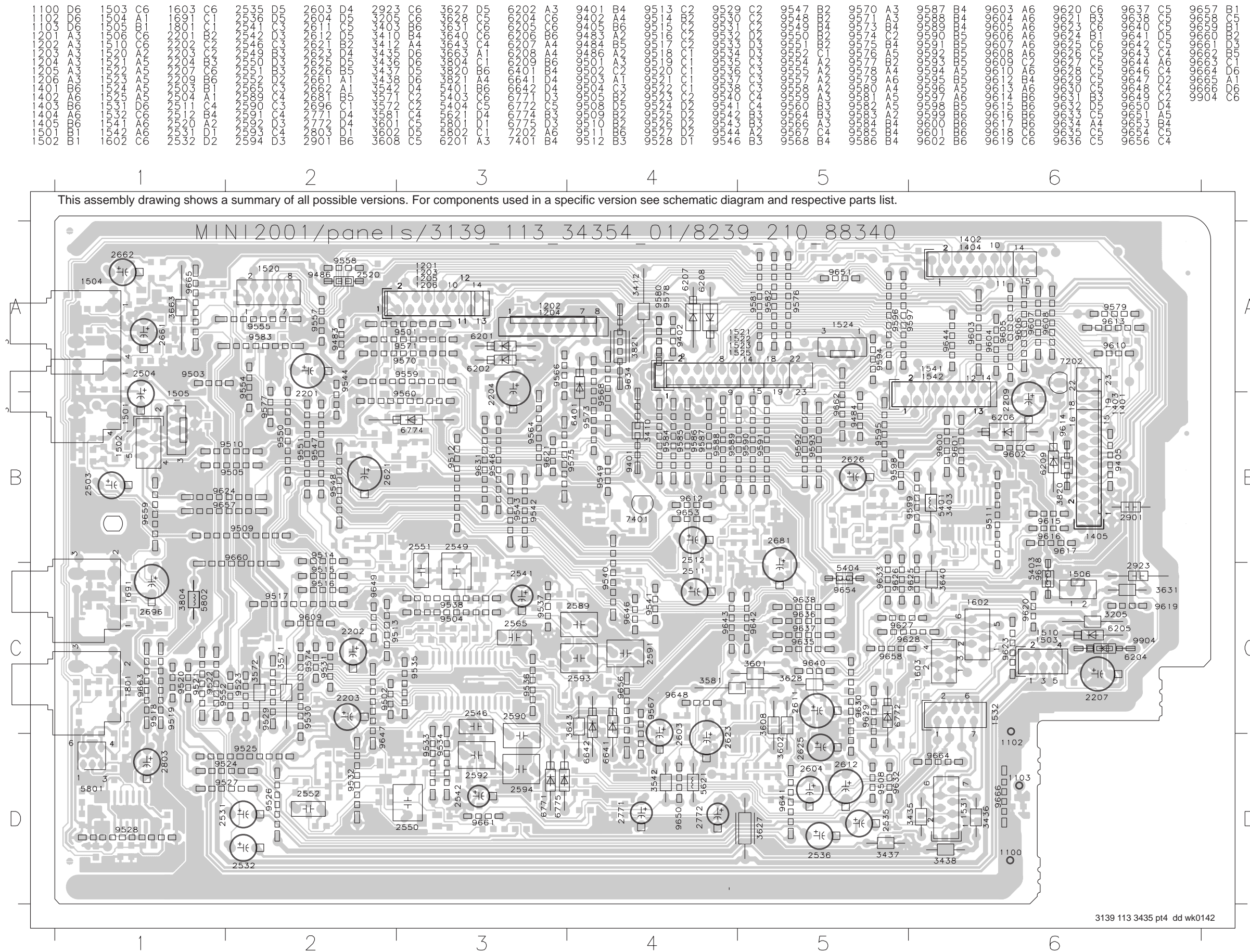

1	2	3	4	5	6
1	2	3	4	5	6
A	B	C	D	A	B
C	D	A	B	C	D

SOURCE SELECTION & SOUND PROCESSING CIRCUIT

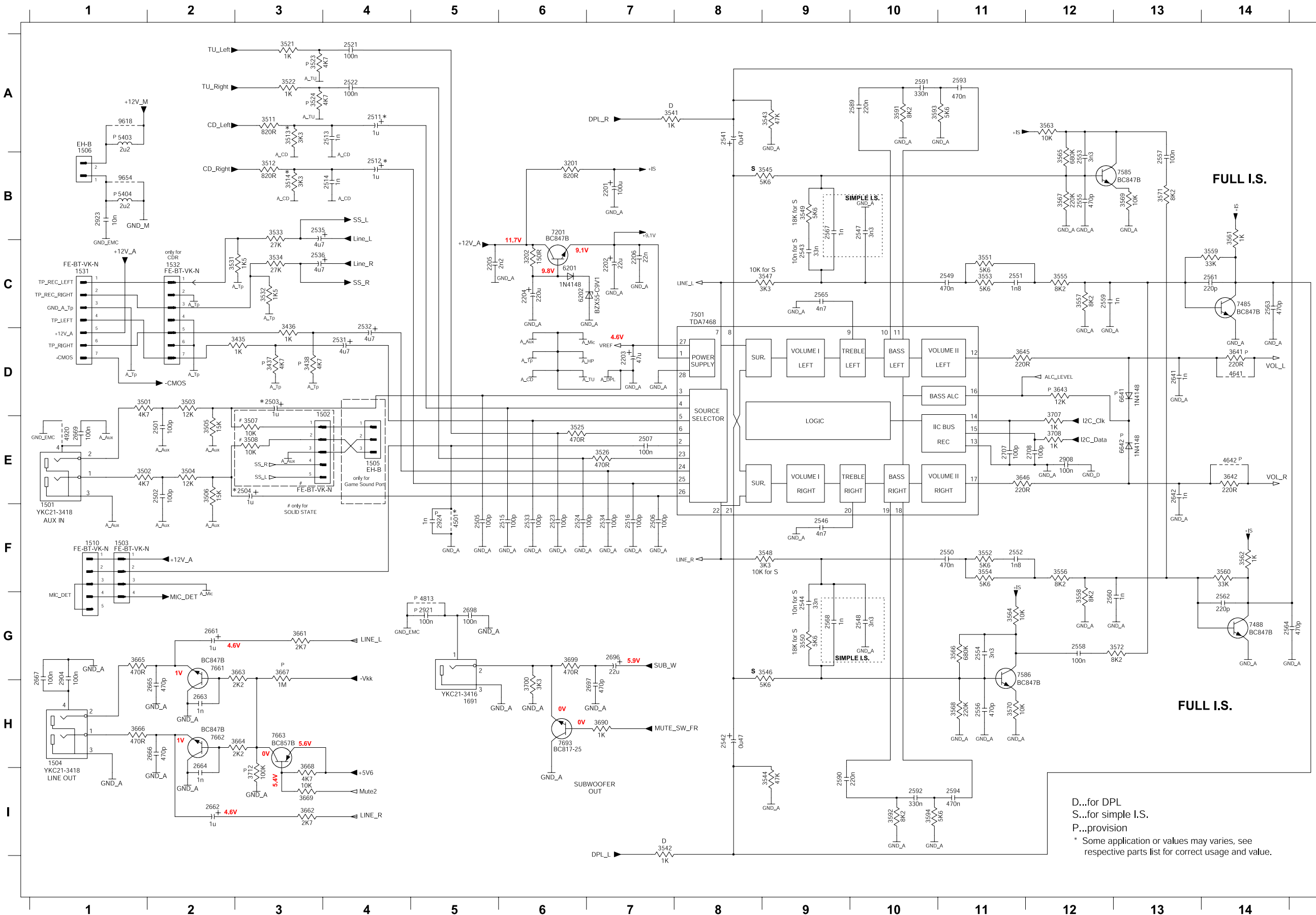

- 1501 E1
- 1502 E3
- 1503 F1
- 1504 H1
- 1505 E4
- 1506 A1
- 1510 F1
- 1531 C1
- 1532 C2
- 1691 H5
- 2201 B7
- 2202 C7
- 2203 D7
- 2204 C6
- 2205 C5
- 2206 C7
- 2501 E2
- 2502 E2
- 2503 D3
- 2504 E3
- 2505 F5
- 2506 F7
- 2507 E7
- 2511 A4
- 2512 B4
- 2513 A4
- 2514 B4
- 2515 F6
- 2516 F7
- 2521 A4
- 2522 A4
- 2523 F6
- 2524 F6
- 2531 D4
- 2532 C4
- 2533 F6
- 2534 F7
- 2535 B3
- 2536 C3
- 2541 A8
- 2542 H8
- 2543 C9
- 2544 G9
- 2546 F9
- 2548 B10
- 2548 G10
- 2548 C11
- 2550 F11
- 2551 C11
- 2552 F11
- 2553 B12
- 2554 G11
- 2555 B12
- 2556 H11
- 2557 B13
- 2558 G12
- 2559 C12
- 2560 G12
- 2561 C14
- 2562 G14
- 2563 C14
- 2564 G14
- 2565 C9
- 2567 B9
- 2568 G9
- 2589 A10
- 2590 I9
- 2591 A10
- 2592 I10
- 2593 A11
- 2594 H11
- 2641 D13
- 2642 E13
- 2661 G2
- 2662 I2
- 2663 H2
- 2664 I2
- 2665 H2
- 2666 H2
- 2667 G1
- 2669 E1
- 2696 G7
- 2697 H7
- 2698 G5
- 2707 E11
- 2708 E12
- 2904 G1
- 2908 E12
- 2921 G5
- 2923 B1
- 2924 F5
- 3201 B6
- 3202 C6
- 3435 D3
- 3436 D3
- 3437 D3
- 3501 D1
- 3502 E1
- 3503 D2
- 3504 E2
- 3505 E2
- 3506 E2
- 3507 E3
- 3508 E3
- 3511 A3
- 3512 B3
- 3513 A3
- 3514 B3
- 3521 A3
- 3522 A3
- 3523 A3
- 3524 A3
- 3525 A3
- 3526 A3
- 3527 A3
- 3528 A3
- 3529 A3
- 3530 A3
- 3531 A3
- 3532 A3
- 3533 A3
- 3534 A3
- 3535 A3
- 3536 A3
- 3537 A3
- 3538 A3
- 3539 A3
- 3540 A3
- 3541 A7
- 3542 I7
- 3543 A9
- 3544 I9
- 3545 B9
- 3546 G9
- 3547 C9
- 3548 F9
- 3549 B9
- 3550 G9
- 3551 C11
- 3552 F11
- 3553 C11
- 3554 F11
- 3555 C12
- 3556 F12
- 3557 C12
- 3558 G12
- 3559 C14
- 3560 F14
- 3561 B14
- 3562 F14
- 3563 A12
- 3564 G11
- 3565 B12
- 3566 G11
- 3567 B12
- 3568 H11
- 3569 B13
- 3570 H11
- 3571 B13
- 3572 G13
- 3591 A10
- 3592 I10
- 3593 A10
- 3594 E14
- 3595 B12
- 3596 D11
- 3597 B13
- 3598 G13
- 3599 C13
- 3601 B3
- 3602 C6
- 3603 G5
- 3604 B1
- 3605 A1
- 3606 C1
- 3607 G3
- 3608 I3
- 3609 H7
- 3699 G6
- 3700 H6
- 3707 E12
- 3708 E12
- 3712 I3
- 4501 F5
- 4641 D14
- 4642 E14
- 4643 G5
- 4920 E1
- 5403 A1
- 5404 B1
- 6201 C6
- 6202 C6
- 6641 D13
- 6642 E13
- 7201 B6
- 7485 C14
- 7488 G14
- 7501 C8
- 7585 B13
- 7586 G11
- 7661 G2
- 7662 H2
- 7663 H3
- 7693 H6
- 9618 A1
- 9654 B1

D...for DPL
 S...for simple I.S.
 P...provision
 * Some application or values may varies, see respective parts list for correct usage and value.

HEADPHONE AMPLIFIER & I²C EXPANDER CIRCUIT

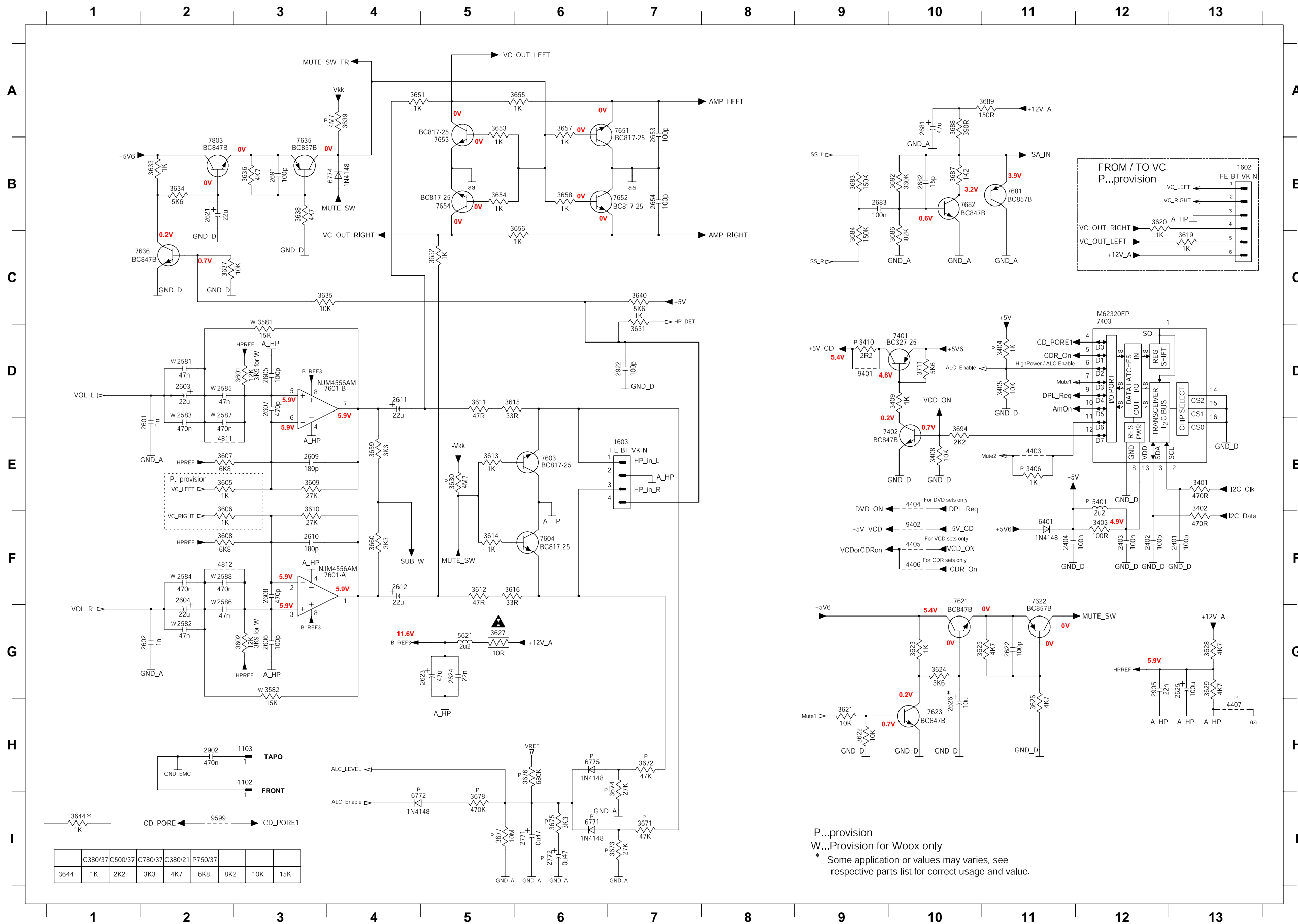

- 1102 H3
- 1103 H3
- 1602 B13
- 1603 E7
- 2401 F13
- 2402 F12
- 2403 F12
- 2404 F11
- 2581 D2
- 2582 G2
- 2583 D2
- 2584 F2
- 2585 D2
- 2586 F2
- 2587 D2
- 2588 F2
- 2601 E2
- 2602 G2
- 2603 D2
- 2604 F2
- 2605 D3
- 2606 G3
- 2607 D3
- 2608 F3
- 2609 E3
- 2610 F3
- 2611 D4
- 2612 F4
- 2621 B2
- 2622 G11
- 2623 G5
- 2624 G5
- 2625 G13
- 2626 H10
- 2653 A7
- 2654 B7
- 2681 A10
- 2682 B10
- 2683 B9
- 2691 B3
- 2771 I6
- 2772 I6
- 2902 H2
- 2905 G12
- 2922 D7
- 3401 E13
- 3402 E13
- 3403 F12
- 3404 D11
- 3405 D11
- 3406 E11
- 3408 E10
- 3409 D10
- 3410 D9
- 3581 D3
- 3582 G3
- 3601 D3
- 3602 G3
- 3605 E2
- 3606 F2
- 3607 E2
- 3608 F2
- 3609 E3
- 3610 F3
- 3611 D5
- 3612 F5
- 3613 E5
- 3614 F5
- 3615 D5
- 3616 F5
- 3619 C13
- 3620 B12
- 3621 H9
- 3622 H9
- 3623 G10
- 3624 G10
- 3625 G10
- 3626 H11
- 3627 G5
- 3628 G13
- 3629 G13
- 3630 E5
- 3631 D7
- 3633 B2
- 3634 B2
- 3635 C3
- 3636 B3
- 3637 C2
- 3638 B3
- 3639 A4
- 3640 C7
- 3644 I1
- 3651 A4
- 3652 C5
- 3653 A5
- 3654 B5
- 3655 A6
- 3656 C6
- 3657 A6
- 3658 B6
- 3659 E4
- 3660 F4
- 3671 I7
- 3672 H7
- 3673 I7
- 3674 H7
- 3675 I6
- 3676 H6
- 3677 I5
- 3678 I5
- 3683 B9
- 3684 C9
- 3686 C10
- 3687 B10
- 3688 A10
- 3689 A11
- 3692 B10
- 3694 E10
- 3711 D10
- 4403 E11
- 4404 E10
- 4405 F10
- 4406 F10
- 4407 H13
- 4811 E2
- 4812 F2
- 5401 E12
- 5621 G5
- 6401 F11
- 6771 I6
- 6772 I4
- 6774 B4
- 6775 H6
- 7401 D10
- 7402 E10
- 7403 C12
- 7601-A G3
- 7601-B D3
- 7603 E6
- 7604 F6
- 7621 F10
- 7622 F11
- 7623 H10
- 7635 B3
- 7636 C2
- 7651 A7
- 7652 B7
- 7653 B5
- 7654 B5
- 7681 B11
- 7682 B10
- 7803 B2
- 9401 D9
- 9402 F10
- 9599 I2

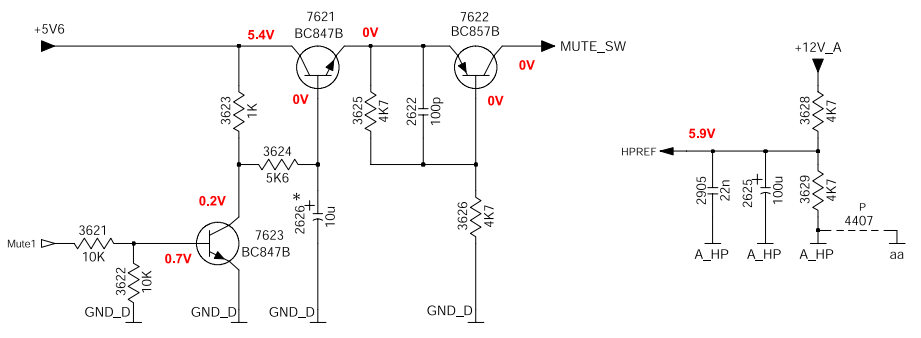
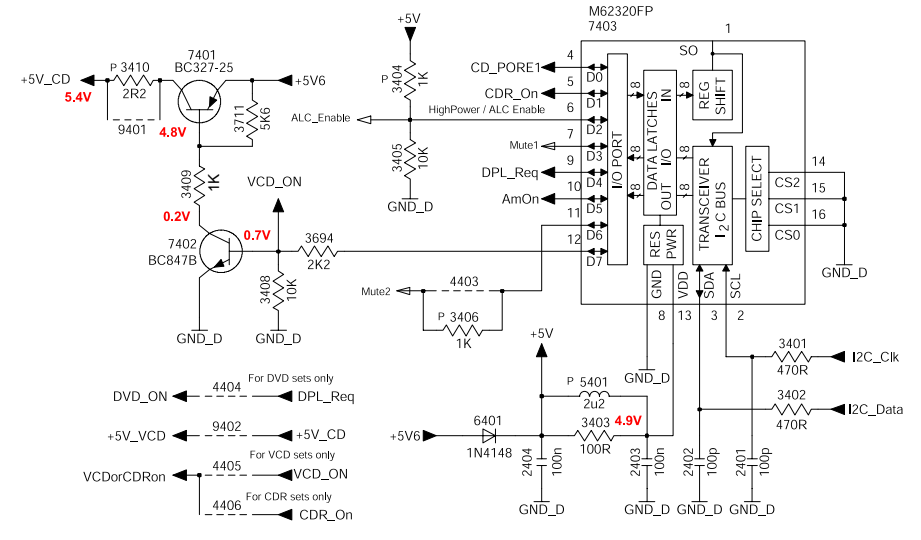
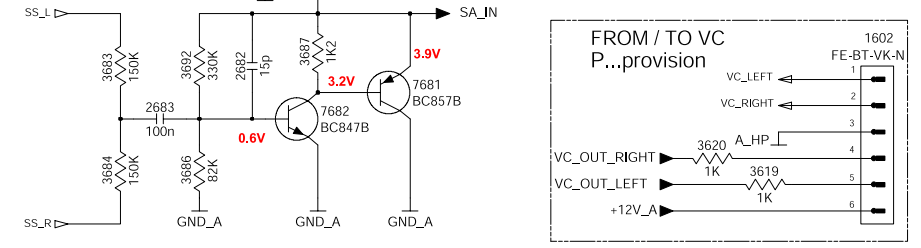

P...provision
 W...Provision for Woox only
 * Some application or values may varies, see respective parts list for correct usage and value.

DIGITAL OUT & INTERCONNECTION CIRCUIT

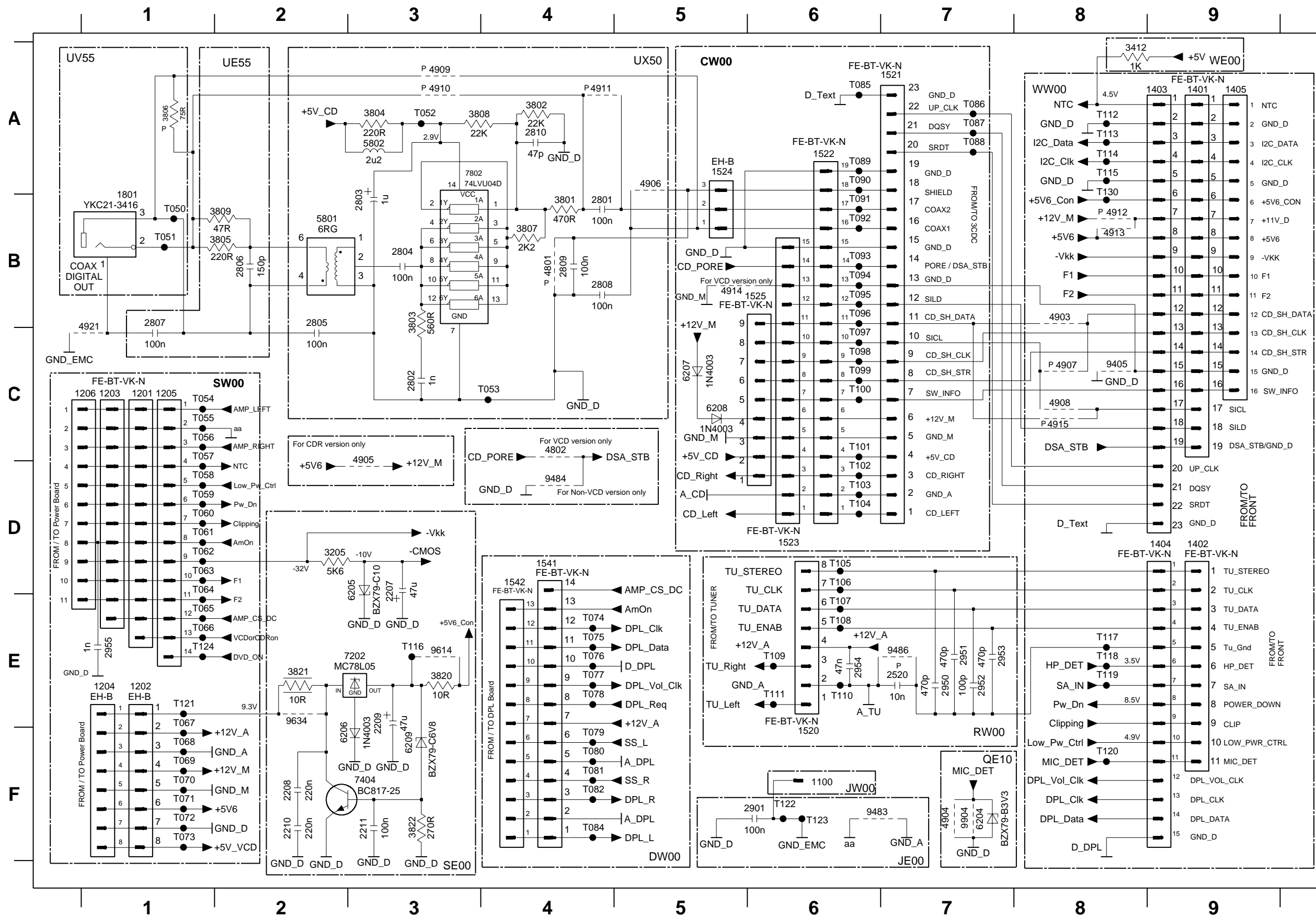

- 1100 F6 T054 C1
- 1201 C1 T055 C1
- 1202 E1 T056 C1
- 1203 C1 T057 C1
- 1204 E1 T058 D1
- 1205 C1 T059 D1
- 1206 C1 T060 D1
- 1401 A9 T061 D1
- 1402 D9 T062 D1
- 1403 A9 T063 D1
- 1404 D9 T064 D1
- 1405 A9 T065 E1
- 1520 E6 T066 E1
- 1521 A7 T067 E1
- 1522 A6 T068 F1
- 1523 D6 T069 F1
- 1524 A5 T070 F1
- 1525 B5 T071 F1
- 1541 D4 T072 F1
- 1542 D4 T073 F1
- 1801 B1 T074 E4
- 2207 D3 T075 E4
- 2208 F2 T076 E4
- 2209 E3 T077 E4
- 2210 F2 T078 E4
- 2211 F3 T079 F4
- 2520 E7 T080 F4
- 2801 B4 T081 F4
- 2802 C3 T082 F4
- 2803 B3 T084 F4
- 2804 B3 T085 A6
- 2805 B2 T086 A7
- 2806 B2 T087 A7
- 2807 B1 T088 A7
- 2808 B4 T089 A6
- 2809 B4 T090 A6
- 2810 A4 T091 B6
- 2901 F6 T092 B6
- 2950 E7 T093 B6
- 2951 E7 T094 B6
- 2952 E7 T095 B6
- 2953 E7 T096 B6
- 2954 E6 T097 C6
- 2955 E1 T098 C6
- 3205 D2 T099 C6
- 3412 A8 T100 C6
- 3801 B4 T101 C6
- 3802 A4 T102 D6
- 3803 B3 T103 D6
- 3804 A3 T104 D6
- 3805 B2 T105 D6
- 3806 A1 T106 D6
- 3807 B4 T107 E6
- 3808 A3 T108 E6
- 3809 B2 T109 E6
- 3820 E3 T110 E6
- 3821 E2 T111 E6
- 3822 F3 T112 A8
- 4801 B4 T113 A8
- 4802 C4 T114 A8
- 4903 B8 T115 A8
- 4904 F7 T116 E3
- 4905 D3 T117 E8
- 4906 A5 T118 E8
- 4907 C8 T119 E8
- 4908 C8 T120 F8
- 4909 A3 T121 E1
- 4910 A3 T122 F6
- 4911 A4 T123 F6
- 4912 B8 T124 E1
- 4913 B8 T130 B8
- 4914 B5 T130 B8
- 4915 B5 T130 B8
- 4916 B5 T130 B8
- 4917 B5 T130 B8
- 4918 B5 T130 B8
- 4919 B5 T130 B8
- 4920 B5 T130 B8
- 4921 B5 T130 B8
- 4922 B5 T130 B8
- 4923 B5 T130 B8
- 4924 B5 T130 B8
- 4925 B5 T130 B8
- 4926 B5 T130 B8
- 4927 B5 T130 B8
- 4928 B5 T130 B8
- 4929 B5 T130 B8
- 4930 B5 T130 B8
- 4931 B5 T130 B8
- 4932 B5 T130 B8
- 4933 B5 T130 B8
- 4934 B5 T130 B8
- 4935 B5 T130 B8
- 4936 B5 T130 B8
- 4937 B5 T130 B8
- 4938 B5 T130 B8
- 4939 B5 T130 B8
- 4940 B5 T130 B8
- 4941 B5 T130 B8
- 4942 B5 T130 B8
- 4943 B5 T130 B8
- 4944 B5 T130 B8
- 4945 B5 T130 B8
- 4946 B5 T130 B8
- 4947 B5 T130 B8
- 4948 B5 T130 B8
- 4949 B5 T130 B8
- 4950 B5 T130 B8
- 4951 B5 T130 B8
- 4952 B5 T130 B8
- 4953 B5 T130 B8
- 4954 B5 T130 B8
- 4955 B5 T130 B8
- 4956 B5 T130 B8
- 4957 B5 T130 B8
- 4958 B5 T130 B8
- 4959 B5 T130 B8
- 4960 B5 T130 B8
- 4961 B5 T130 B8
- 4962 B5 T130 B8
- 4963 B5 T130 B8
- 4964 B5 T130 B8
- 4965 B5 T130 B8
- 4966 B5 T130 B8
- 4967 B5 T130 B8
- 4968 B5 T130 B8
- 4969 B5 T130 B8
- 4970 B5 T130 B8
- 4971 B5 T130 B8
- 4972 B5 T130 B8
- 4973 B5 T130 B8
- 4974 B5 T130 B8
- 4975 B5 T130 B8
- 4976 B5 T130 B8
- 4977 B5 T130 B8
- 4978 B5 T130 B8
- 4979 B5 T130 B8
- 4980 B5 T130 B8
- 4981 B5 T130 B8
- 4982 B5 T130 B8
- 4983 B5 T130 B8
- 4984 B5 T130 B8
- 4985 B5 T130 B8
- 4986 B5 T130 B8
- 4987 B5 T130 B8
- 4988 B5 T130 B8
- 4989 B5 T130 B8
- 4990 B5 T130 B8
- 4991 B5 T130 B8
- 4992 B5 T130 B8
- 4993 B5 T130 B8
- 4994 B5 T130 B8
- 4995 B5 T130 B8
- 4996 B5 T130 B8
- 4997 B5 T130 B8
- 4998 B5 T130 B8
- 4999 B5 T130 B8
- 5000 B5 T130 B8

Updated on 15 SEPT 2003

VIDEO OUT PART - COMPONENT & CHIP LAYOUTS

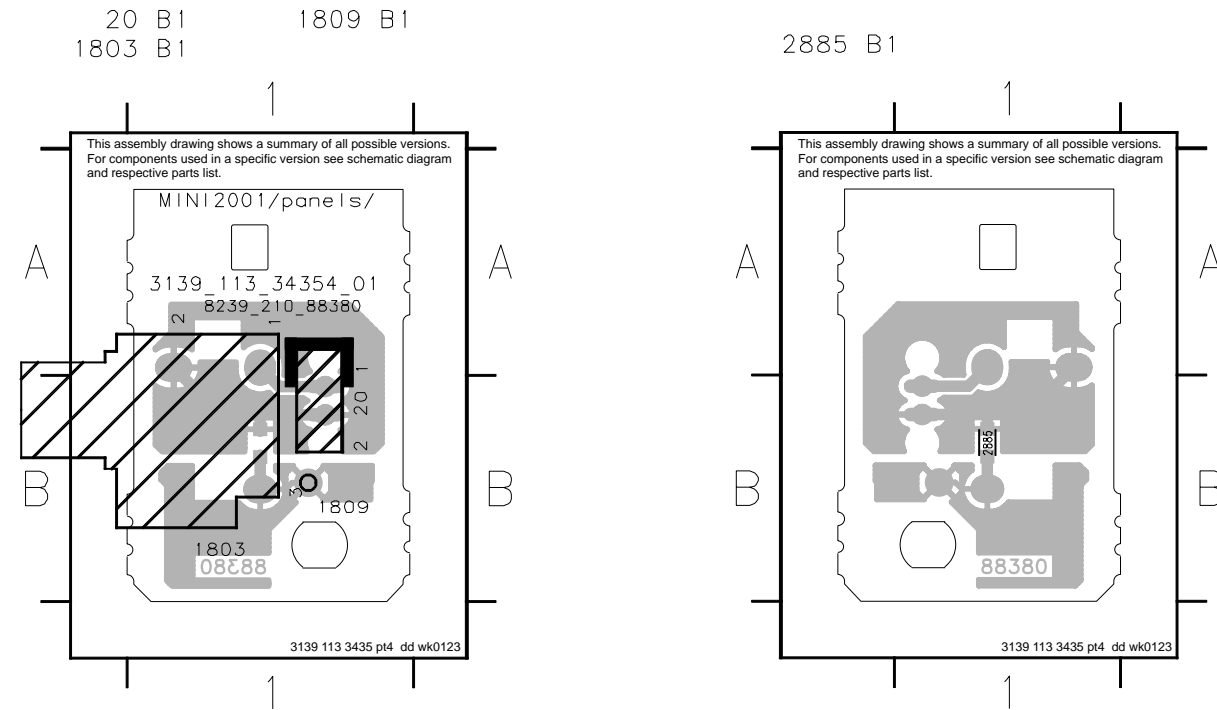

CIRCUIT DIAGRAM - VIDEO OUT PART

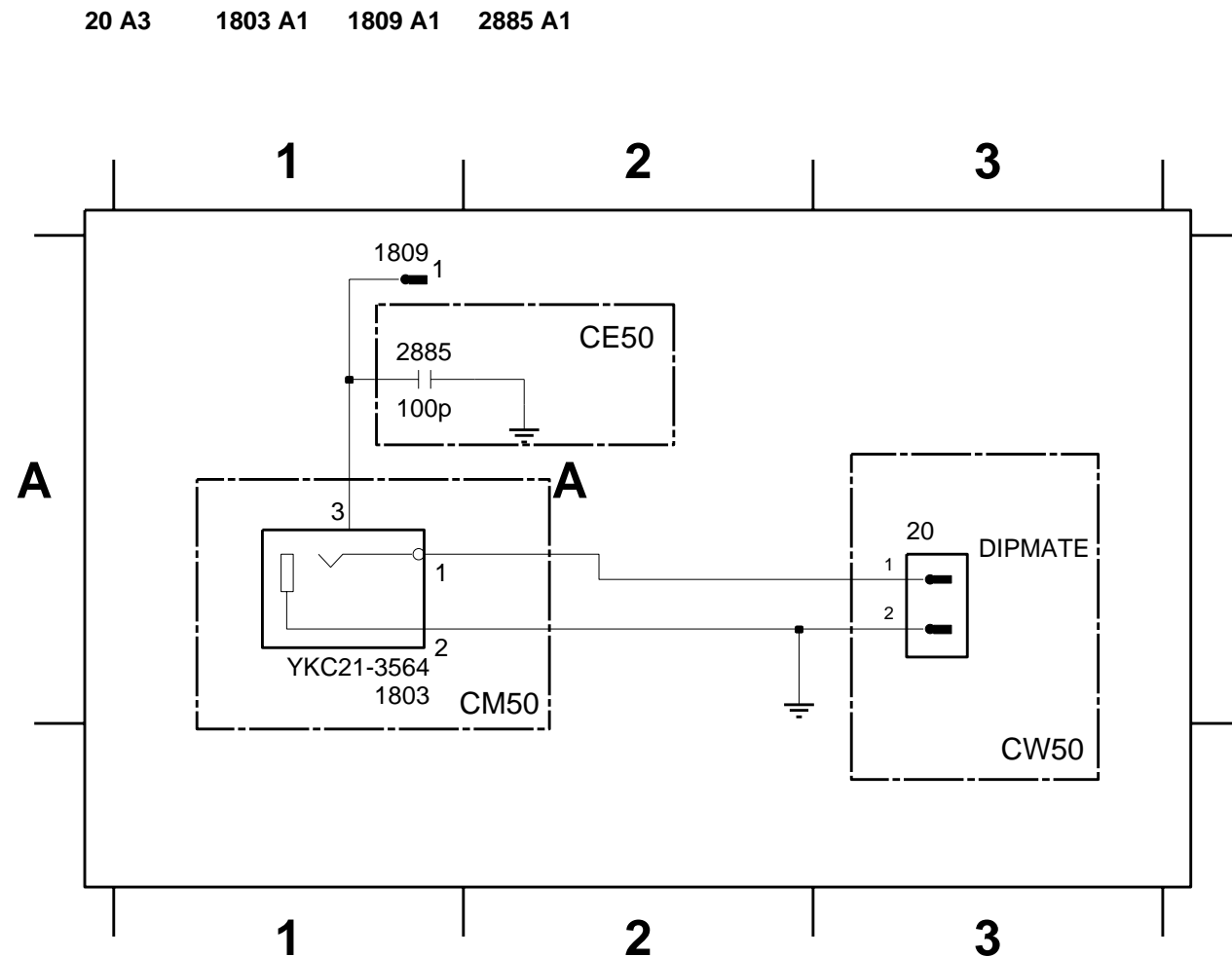

ELECTRICAL PARTSLIST - AF-9 BOARD

- MISCELLANEOUS -			- CAPACITORS -		
1100	4822 267 10676	CONNECTOR	2535	4822 124 40769	4,7µF 20% 100V
1102	4822 267 10676	CONNECTOR	2536	4822 124 40769	4,7µF 20% 100V
1103	4822 267 10676	CONNECTOR	2541	4822 124 41407	0,47µF 20% 63V
1204	2422 025 17466	CONNECTOR V 7P	2542	4822 124 41407	0,47µF 20% 63V
1206	4822 267 11039	CONNECTOR	2543	5322 126 11583	10nF 10% X7R 50V
1401	4822 265 11553	CONNECTOR 19P	2544	5322 126 11583	10nF 10% X7R 50V
1402	4822 267 11039	CONNECTOR 11P	2546	4822 121 43856	4,7nF 5% 250V
1501	4822 265 20553	CONNECTOR	2547	5322 126 11579	3,3nF 10% X7R 63V
1506	2412 020 00724	CONNECTOR V 2P	2548	5322 126 11579	3,3nF 10%X7R 63V
1520	4822 265 11515	CONNECTOR V 8P	2565	4822 121 43856	4,7nF 5% 250V
1523	4822 265 10981	CONNECTOR	2567	3198 016 31020	1nF NP0 25V
1531	4822 267 10953	CONNECTOR	2568	3198 016 31020	1nF NP0 25V
1603	4822 267 10733	CONNECTOR	2589	4822 121 42408	220nF 5% 63V
			2590	4822 121 42408	220nF 5% 63V
			2591	5322 121 42661	330nF 5% 63V
2201	4822 124 40207	100µF 20% 25V	2592	5322 121 42661	330nF 5% 63V
2202	4822 124 81151	22µF 50V	2593	4822 121 51252	470nF 5% 63V
2203	4822 124 40433	47µF 20% 25V	2594	4822 121 51252	470nF 5% 63V
2204	4822 124 40196	220µF 20% 16V	2601	3198 016 31020	1nF NP0 25V
2205	4822 126 14238	2,2nF X7R 50V	2602	3198 016 31020	1nF NP0 25V
2206	2238 916 15641	22nF 10%X7R 25V	2603	4822 124 81151	22µF 50V
2207	4822 124 40433	47µF 20% 25V	2604	4822 124 81151	22µF 50V
2208	4822 126 13879	220nF +80-20% 16V	2605	2020 552 94427	100pF 5% NP0 50V
2209	4822 124 41751	47µF 20% 50V	2606	2020 552 94427	100pF 5% NP0 50V
2210	4822 126 13879	220nF +80-20% 16V	2607	4822 126 13881	470pF 5% 50V
2401	2020 552 94427	100pF 5% NP0 50V	2608	4822 126 13881	470pF 5% 50V
2402	2020 552 94427	100pF 5% NP0 50V	2609	4822 126 14508	180pF 5% 50V NP0
2403	2238 586 59812	100nF +80-20% Y5V 50V	2610	4822 126 14508	180pF 5% 50V NP0
2404	2238 586 59812	100nF +80-20% Y5V 50V	2611	4822 124 81151	22µF 50V
2501	2020 552 94427	100pF 5% NP0 50V	2612	4822 124 81151	22µF 50V
2502	2020 552 94427	100pF 5% NP0 50V	2621	4822 124 81151	22µF 50V
2503	2022 020 00734	1µF 20% 50V	2622	4822 126 13881	100pF 5% NP0 50V
2504	2022 020 00734	1µF 20% 50V	2623	4822 124 40433	47µF 20% 25V
2505	2020 552 94427	100pF 5% NP0 50V	2624	3198 017 42230	22nF Y5V 50V
2506	2020 552 94427	100pF 5% NP0 50V	2625	4822 124 40207	100µF 20% 25V
2507	2238 586 59812	100nF +80-20% Y5V 50V	2626	4822 124 40769	4,7µF 20% 100V
2511	2022 020 00734	1µF 20% 50V	2641	3198 016 31020	1nF NP0 25V
2512	2022 020 00734	1µF 20% 50V	2642	3198 016 31020	1nF NP0 25V
2513	3198 016 31020	1nF NP0 25V	2653	2020 552 94427	100pF 5% NP0 50V
2514	3198 016 31020	1nF NP0 25V	2654	2020 552 94427	100pF 5% NP0 50V
2515	2020 552 94427	100pF 5% NP0 50V	2669	2238 586 59812	100nF +80-20% Y5V 50V
2516	2020 552 94427	100pF 5% NP0 50V	2681	4822 124 40433	47µF 20% 25V
2521	2238 586 59812	100nF +80-20% Y5V 50V	2682	4822 122 33752	15pF 5% NP0 50V
2522	2238 586 59812	100nF +80-20% Y5V 50V	2683	2238 586 59812	100nF +80-20% Y5V 50V
2523	2020 552 94427	100pF 5% NP0 50V	2691	2020 552 94427	100pF 5% NP0 50V
2524	2020 552 94427	100pF 5% NP0 50V	2707	2020 552 94427	100pF 5% NP0 50V
2531	4822 124 40769	4,7µF 20% 100V	2708	2020 552 94427	100pF 5% NP0 50V
2532	4822 124 40769	4,7µF 20% 100V	2771	4822 124 41407	0,47µF 20% 63V
2533	2020 552 94427	100pF 5% NP0 50V	2902	3198 017 44740	470nF Y5V 10V
2534	2020 552 94427	100pF 5% NP0 50V	2905	3198 017 42230	22nF Y5V 50V

ELECTRICAL PARTSLIST - AF-9 BOARD**- CAPACITORS -**

2908	2238 586 59812	100nF +80-20% Y5V 50V
2922	2020 552 94427	100pF 5% NP0 50V
2923	4822 121 51387	10nF 20% 16V

- RESISTORS -

3201	4822 117 12968	820Ω 5% 0,62W
3202	4822 051 30151	150Ω 5% 0,062W
3205	4822 116 52289	5,6K 5% 0,5W
3401	4822 051 30471	470Ω 5% 0,062W
3402	4822 051 30471	470Ω 5% 0,062W

3403	4822 116 52175	100Ω 5% 0,5W
3405	4822 051 30103	10K 5% 0,062W
3408	4822 051 30103	10K 5% 0,062W
3409	4822 051 30102	10K 5% 0,062W
3412	4822 050 11002	1K 1% 0,4W

3435	4822 050 11002	1K 1% 0,4W
3436	4822 050 11002	1K 1% 0,4W
3501	4822 051 30472	4,7K 5% 0,062W
3502	4822 051 30472	4,7K 5% 0,062W
3503	4822 051 30123	12K 5% 0,062W

3504	4822 051 30123	12K 5% 0,062W
3505	4822 051 30153	15K 5% 0,062W
3506	4822 051 30153	15K 5% 0,062W
3511	4822 117 12968	820Ω 5% 0,62W
3512	4822 117 12968	820Ω 5% 0,62W

3513	4822 117 12903	1,8K 1% 0,063W
3514	4822 117 12903	1,8K 1% 0,063W
3521	4822 051 30102	10K 5% 0,062W
3522	4822 051 30102	10K 5% 0,062W
3525	4822 051 30471	470Ω 5% 0,062W

3526	4822 051 30471	470Ω 5% 0,062W
3531	4822 051 30152	1,5K 5% 0,062W
3532	4822 051 30152	1,5K 5% 0,062W
3533	4822 051 30273	27K 5% 0,062W
3534	4822 051 30273	27K 5% 0,062W

3543	4822 117 12925	47K 1% 0,063W
3544	4822 117 12925	47K 1% 0,063W
3545	4822 051 30562	5,6K 5% 0,063W
3546	4822 051 30562	5,6K 5% 0,063W
3547	4822 051 30103	10K 5% 0,062W

3548	4822 051 30103	10K 5% 0,062W
3549	4822 051 30183	18K 5% 0,062W
3550	4822 051 30183	18K 5% 0,062W
3591	5322 117 13056	8,2K 1% 0,063W
3592	5322 117 13056	8K2 1% 0,063W

3593	4822 051 30562	5,6K 5% 0,063W
3594	4822 051 30562	5,6K 5% 0,063W
3601	4822 116 52238	12K 5% 0,5W
3602	4822 116 52238	12K 5% 0,5W
3607	4822 051 30682	6,8K 5% 0,062W

- RESISTORS -

3608	4822 116 83961	6,8K 5%
3609	4822 051 30273	27K 5% 0,062W
3610	4822 051 30273	27K 5% 0,062W
3611	4822 051 30479	47Ω 5% 0,062W
3612	4822 051 30479	47Ω 5% 0,062W

3613	4822 051 30102	1K 5% 0,062W
3614	4822 051 30102	1K 5% 0,062W
3615	4822 051 30339	33Ω 5% 0,062W
3616	4822 051 30339	33Ω 5% 0,062W
3621	4822 051 30103	10K 5% 0,062W

3622	4822 051 30103	10K 5% 0,062W
3623	4822 051 30102	1K 5% 0,062W
3624	4822 051 30562	5,6K 5% 0,063W
3625	4822 051 30472	4,7K 5% 0,062W
3626	4822 051 30472	4,7K 5% 0,062W

3627	4822 052 10109	10Ω 5% 0,33W
3628	4822 116 52283	4,7K 5% 0,062W
3629	4822 051 30472	4,7K 5% 0,062W
3631	4822 050 11002	1K 1% 0,4W
3633	4822 051 30102	1K 5% 0,062W

3634	4822 051 30562	5,6K 5% 0,063W
3635	4822 051 30103	10K 5% 0,062W
3636	4822 051 30472	4,7K 5% 0,062W
3637	4822 051 30103	10K 5% 0,062W
3638	4822 051 30472	4,7K 5% 0,062W

3640	4822 116 52289	5,6K 5% 0,5W
3644	4822 051 30102	1K 5% 0,062W
3645	4822 051 30221	220Ω 5% 0,062W
3646	4822 051 30221	220Ω 5% 0,062W
3651	4822 051 30102	1K 5% 0,062W

3652	4822 051 30102	1K 5% 0,062W
3653	4822 051 30102	1K 5% 0,062W
3654	4822 051 30102	1K 5% 0,062W
3655	4822 051 30102	1K 5% 0,062W
3656	4822 051 30102	1K 5% 0,062W

3657	4822 051 30102	1K 5% 0,062W
3658	4822 051 30102	1K 5% 0,062W
3683	4822 051 30154	150K 5% 0,062W
3684	4822 051 30154	150K 5% 0,062W
3686	4822 117 12864	82K 5% 0,6W

3687	4822 117 11817	1,2K 1% 1/16W
3688	4822 051 30391	390Ω 5% 0,062W
3689	4822 051 30151	150Ω 5% 0,062W
3692	4822 051 30334	330K 5% 0,062W
3694	4822 051 30222	2,2K 5% 0,062W

3707	4822 051 30102	1K 5% 0,062W
3708	4822 051 30102	1K 5% 0,062W
3711	4822 051 30562	5,6K 5% 0,063W
3820	4822 116 52176	10Ω 5% 0,5W
3821	4822 052 10109	10Ω 5% 0,33W

ELECTRICAL PARTSLIST - AF-9 BOARD**- RESISTORS -**

4100	4822 051 30008	0Ω JUMPER
4101	4822 051 30008	0Ω JUMPER
4104	4822 051 30008	0Ω JUMPER
4108	4822 051 30008	0Ω JUMPER
4110	4822 051 30008	0Ω JUMPER

4111	4822 051 30008	0Ω JUMPER
4112	4822 051 30008	0Ω JUMPER
4113	4822 051 30008	0Ω JUMPER
4114	4822 051 30008	0Ω JUMPER
4115	4822 051 30008	0Ω JUMPER

4116	4822 051 30008	0Ω JUMPER
4119	4822 051 30008	0Ω JUMPER
4122	4822 051 30008	0Ω JUMPER
4124	4822 051 30008	0Ω JUMPER
4125	4822 051 30008	0Ω JUMPER

4126	4822 051 30008	0Ω JUMPER
4127	4822 051 30008	0Ω JUMPER
4128	4822 051 30008	0Ω JUMPER
4130	4822 051 30008	0Ω JUMPER
4132	4822 051 30008	0Ω JUMPER

4133	4822 051 30008	0Ω JUMPER
4134	4822 051 30008	0Ω JUMPER
4135	4822 051 30008	0Ω JUMPER
4137	4822 051 30008	0Ω JUMPER
4138	4822 051 30008	0Ω JUMPER

4139	4822 051 30008	0Ω JUMPER
4141	4822 051 30008	0Ω JUMPER
4142	4822 051 30008	0Ω JUMPER
4143	4822 051 30008	0Ω JUMPER
4144	4822 051 30008	0Ω JUMPER

4145	4822 051 30008	0Ω JUMPER
4146	4822 051 30008	0Ω JUMPER
4147	4822 051 30008	0Ω JUMPER
4148	4822 051 30008	0Ω JUMPER
4151	4822 051 30008	0Ω JUMPER

4152	4822 051 30008	0Ω JUMPER
4153	4822 051 30008	0Ω JUMPER
4501	4822 051 30008	0Ω JUMPER
4641	4822 051 30008	0Ω JUMPER
4642	4822 051 30008	0Ω JUMPER

4802	4822 051 30008	0Ω JUMPER
4811	4822 051 30008	0Ω JUMPER
4812	4822 051 30008	0Ω JUMPER
4904	4822 051 30008	0Ω JUMPER
4907	4822 051 30008	0Ω JUMPER

4913	4822 051 30008	0Ω JUMPER
4915	4822 051 30008	0Ω JUMPER
4920	4822 051 30008	0Ω JUMPER

- COILS & FILTERS -

5621	4822 157 62552	2,2μH
------	----------------	-------

- DIODES -

6201	4822 130 30621	1N4148
6202	4822 130 30862	BZX79-B9V1
6205	4822 130 61219	BZX79-B10
6206	4822 130 31878	1N4003G
6207	4822 130 31878	1N4003G

6208	4822 130 31878	1N4003G
6401	4822 130 30621	1N4148
6774	4822 130 30621	1N4148

- IC & TRANSISTORS -

7201	5322 130 60159	BC846B
7202	4822 209 72042	L78L05ACZ
7401	4822 130 41246	BC327-25
7402	5322 130 60159	BC846B
7403	4822 209 17345	M62320FP

7501	9322 150 74668	TDA7468D
7601	4822 209 31378	NJM4556MB
7603	4822 130 42804	BC817-25
7604	4822 130 42804	BC817-25
7621	5322 130 60159	BC846B

7622	4822 130 60373	BC856B
7623	5322 130 60159	BC846B
7635	4822 130 60373	BC856B
7636	5322 130 60159	BC846B
7651	4822 130 42804	BC817-25

7652	4822 130 42804	BC817-25
7653	4822 130 42804	BC817-25
7654	4822 130 42804	BC817-25
7681	4822 130 60373	BC856B
7682	5322 130 60159	BC846B

7803	5322 130 60159	BC846B
------	----------------	--------

Note: Only these parts mentioned in the list are normal service parts.

EXPLODED VIEW - MAIN UNIT

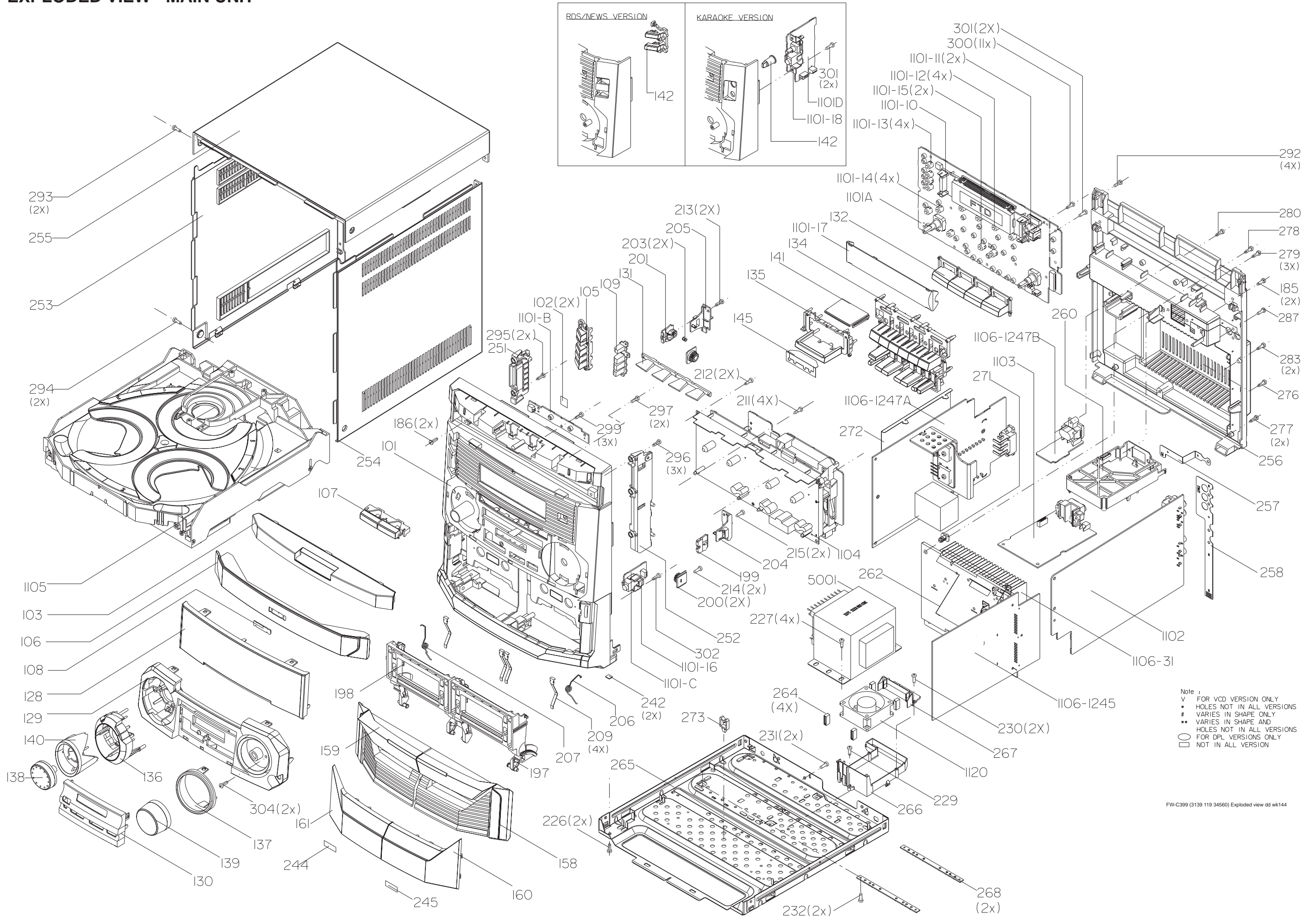

MECHANICAL PARTSLIST**ACCESSORIES****SCREW LISTS - MAIN UNIT**

101	3140 117 71061	CAB FRONT /21	350	3140 118 51721	BOX SPK ASSY	185	D3 x 12
101	3140 117 71051	CAB FRONT /22/25	351	4822 303 50063	FM ANTENNA	186	D3 x 12
103	3140 117 69751	COVER FRONT CDC /21	356	3139 238 06131	REMOTE CONTROL	211	D3 x 12
103	3140 117 71831	COVER FRONT CDC /22/25	384	4822 303 50082	ANT AM LOOP LAN-006 B	212	D3 x 12
105	3140 117 64710	BTN SET C/CDC SEL /21	385	△ 2422 070 98151	MAINSCORD /21/22	213	D3 x 12
105	3140 117 64540	BTN SET CDC LPS C390 /22/25	385	△ 9965 000 07586	MAINSCORD /25		
106	3140 117 69931	COVER TRAY M399	386	△ 3139 128 73010	ADAPTER PLUG /21	214	D3 x 12
107	3140 117 69761	BUTTON SET OPEN/CLOSE	5001	△ 3103 308 30702	TRANSF. MAINS /21	215	D3 x 12
108	4822 454 13408	BADGE PHILIPS	5001	△ 3103 308 30692	TRANSF. MAINS /22/25	226	M3 x 6
128	3140 117 69951	WINDOW DISPLAY /21	8002	3139 110 35011	FFC FOIL 07P/340/07P AD	227	M3 x 10
128	3140 117 69891	WINDOW DISPLAY /22/25	8003	3139 110 35350	FFC FOIL 11P/220/11P AD	229	M3 x 10
129	3140 117 69961	COVER FRONT DISPLAY	8005	3139 110 35110	FFC FOIL 04P/220/04P AD		
130	3140 117 69971	COVER FRONT ORNA.	8006	4822 320 12703	7P - 140MM	230	D3 x 10
131	3139 114 71350	LIGHTGUIDE SOURCE SELECT	8007	3139 110 35100	FFC FOIL 19P/140/19P AD	231	M3 x 10
132	3140 117 69981	BUTTON SET SOURCE	8008	3139 110 34610	FFC FOIL 11P/180/11P AD	232	M3 x 6
134	3140 117 71601	BTN SET C/PROG N VCD	8009	3139 110 33960	FFC FOIL 04P/120/04P BD	276	M3 x 6
135	3140 117 69811	BUTTON MAX	8011	3139 110 35050	FFC FOIL 08P/220/08P AD	277	M3 x 10
136	3140 117 70001	BUTTON DSC/DBB/VEC/IS	8012	4822 320 12752	7P - 180MM		
137	3140 117 64641	RING VOLUME	8014	3139 110 35881	FFC FOIL 15P/180/15P BD	278	D3 x 16
138	3140 117 70011	KNOB ROTARY				279	D3 x 12
139	3140 117 71481	KNOB VOLUME				280	D3 x 12
140	3139 114 71330	LIGHTGUIDE DSC/DBB/VEC/IS				283	D3 x 12
142	3140 117 64751	BUT SET RDS/NEWS /22/25				287	D3 x 12
158	3140 117 70031	COVER CASS RIGHT					
159	3140 117 70041	COVER CASS LEFT				292	D3 x 12
160	3140 117 69871	LENS CASS RIGHT				293	D3 x 12
161	3140 117 69881	LENS CASS LEFT				294	M3 x 10
197	3139 114 68630	DOOR CASSETTE RIGHT ETF				295	D3 x 12
198	3139 114 68620	DOOR CASSETTE LEFT ETF				296	D3 x 12
199	4822 402 10621	PUSH-CATCH					
200	4822 529 10322	DAMPER ASSY				297	D3 x 12
201	3139 114 68640	PUSH CATCH LEFT				299	D3 x 12
203	4822 492 11344	SPRING COMPRESSION				300	D3 x 12
204	4822 402 11246	BRACKET RIGHT				301	D3 x 12
205	4822 402 11245	BRACKET LEFT				302	D3 x 12
206	3139 111 01380	SPRING TORSION RIGHT					
207	3139 111 01390	SPRING TORSION LEFT				304	D3 x 12
209	4822 492 42787	SPRING CASSETTE					
242	4822 462 40683	RUBBER FOOT					
251	3139 114 70970	BRACKET CDC LEFT					
252	3139 114 70980	BRACKET CDC RIGHT					
253	3139 114 73570	PANEL LEFT					
254	3139 114 73580	PANEL RIGHT					
255	3139 114 73590	COVER TOP					
256	3140 114 63231	PANEL REAR /21					
256	3140 114 63241	PANEL REAR /22/25					
271	3139 114 71010	STOPPER HEATSINK					

Note: Only these parts mentioned in the list are normal service parts.